



Fire Your Imagination

Riva2 500

Inset Convector Fire - Conventional Flue
with Thermostatic Remote Control



Instructions for Use, Installation & Servicing

For use in GB & IE (Great Britain & Republic of Ireland).

IMPORTANT

THE OUTER CASING, FRONT AND GLASS PANEL BECOME EXTREMELY HOT DURING OPERATION AND WILL RESULT IN SERIOUS INJURY AND BURNS IF TOUCHED. IT IS THEREFORE RECOMMENDED THAT A FIREGUARD COMPLYING WITH BS 8423:2002 IS USED IN THE PRESENCE OF YOUNG CHILDREN, THE ELDERLY OR INFIRM.

This product contains a Heat resistant glass panel. This panel should be checked during Installation and at each servicing interval. If any damage is observed on the front face of the glass panel (scratches, scores, cracks or other surface defects), the glass panel must be replaced and the appliance must not be used until a replacement is installed. Under no circumstances should the appliance be used if any damage is observed, the glass panel is removed or broken.

It is essential that ALL of the screws that retain the glass frame are replaced and tightened correctly. Under no circumstances should the appliance be operated if any of these screws are loose or missing.

These Instructions must be left with the appliance for future reference and for consultation when servicing the appliance. Please make the customer aware of the correct operation of the appliance before leaving these instructions with them.

The commissioning sheet found on Page 3 of this Instruction manual must be completed by the Installer prior to leaving the premises.

Contents

Riva2 500 - Conventional Flue

Covering the following models:

Riva2 500 Nat Gas	Riva2 500 LPG
134-204	134-451

Appliance Commissioning Checklist	3
User Instructions	4
Installation Instructions	14
Technical Specifications	14
Site Requirements	15
Installation	17
Commissioning	28
Servicing Instructions	30
Fault Finding	31
How to Replace Parts	33
Basic Spare Parts List	40
Service Records	41



To receive your Extended Warranty your Gazco appliance must have been purchased from our Expert Retailer Network and registered within one month of purchase or installation. Please note that all warranties are effective from the date of purchase. Any Gazco product purchased outside of our Extended Retailer Network, or not registered within the stated time will carry a standard 12 month warranty.

It is a condition of the Extended Warranty that the installation complies with the relevant Building Regulations and is carried out by a suitably trained and qualified individual (GasSafe in the UK or equivalent in other countries) with the certificate of installation and the Commissioning Report on Page 3 completed and retained by the end user.

Full terms and conditions are detailed in the Warranty Statement on the Gazco website www.gazco.com. In the event of any conflict of information the wording on the website shall prevail.

Important Note: Should any problems be experienced with your product, claims must first be submitted to the Expert Retailer where the appliance was purchased from who will offer immediate assistance or contact Gazco on your behalf.

Appliance Commissioning Checklist

To assist us in any guarantee claim please complete the following information:-

IMPORTANT NOTICE

Explain the operation of the appliance to the end user, hand the completed instructions to them for safe keeping, as the information will be required when making any guaranteed claims.

FLUE CHECK	PASS	FAIL
1. Flue Is correct for appliance		
2. Flue flow Test		
3. Spillage Test		
GAS CHECK		
1. Gas soundness & let by test		
2. Standing gas pressure	mb	
3. Appliance working pressure (on High Setting NB All other gas appliances must be operating on full	mb	
4. Gas rate	m ³ /h	
5. Does Ventilation meet appliance requirements N/A		
SAFETY CHECK		
1. Glass checked to ensure no damage, scratches, scores or cracks.		
2. Glass frame secured correctly and all screws replaced		

RETAILER AND INSTALLER INFORMATION

Retailer.....

 Contact No.....
 Date of Purchase.....
 Model No.
 Serial No.....
 Gas Type

Installation Company.....

 Engineer.....
 Contact No.....
 Gas Safe Reg No.
 Date of Installation

User Instructions

Welcome

Congratulations on purchasing your Riva2 fire, if installed correctly Gazco hope it will give you many years of warmth and pleasure for which it was designed.

The purpose of this manual is to familiarise you with your appliance, and give guidelines for its installation, operation and maintenance. If, after reading, you need further information, please do not hesitate to contact your Gazco retailer.

WARNING



In the event of a gas escape or if you can smell gas, please take the following steps:

- Immediately turn off the gas supply at the meter/emergency control valve
- Extinguish all sources of ignition
- Do not smoke
- Do not operate any electrical light or power switches (On or Off)
- Ventilate the building(s) by opening doors and windows
- Ensure access to the premises can be made

Please report the incident immediately to the National Gas Emergency Service Call Centre on 0800 111 999 (England, Scotland and Wales) , 0800 002 001 (N. Ireland) or in the case of LPG, the gas supplier whose details can be found on the bulk storage vessel or cylinder.

The gas supply must not be used until remedial action has been taken to correct the defect and the installation has been recommissioned by a competent person.

1. General

- 1.1 Installation and servicing must only be carried out by a competent person whose name appears on the Gas Safe register. To ensure the engineer is registered with Gas Safe they should possess an ID Card carrying the following logo:



- 1.2 In all correspondence, please quote the appliance type and serial number, which can be found on the data badge located on a plate attached to the lower slotted trim.

- 1.3 Do not place curtains above the appliance: You must have 300mm (1') clearance between the appliance and any curtains at either side.
- 1.4 No furnishings or other objects should be placed within 1 metre of the front of the appliance.
- 1.5 If a shelf is fitted, a distance of 150mm above the appliance is required.
- 1.6 If any cracks appear in the glass panel do not use the appliance until the panel has been replaced.
- 1.7 In the unlikely event the appliance is receiving interference from other electronic devices, the handset/Control box can be reprogrammed. Please refer to the commissioning section in order to change the communication channel.
- 1.8 This product is guaranteed for 5 years from the date of installation, as set out in the terms and conditions of sale between Gazco and your local Gazco retailer. Please consult with your local Gazco retailer if you have any questions. In all correspondence always quote the Model Number and Serial Number.

2. Operating the Appliance

- 2.1 The appliance has 4 flame settings:
1. High.
 2. Medium.
 3. Low.
 4. Standby (Pilot only).
- 2.2 Both touch pad and handset allow you to manually switch between flame settings.
- 2.3 The Thermostatic handset also allows to set the appliance to automatically regulate the room temperature.

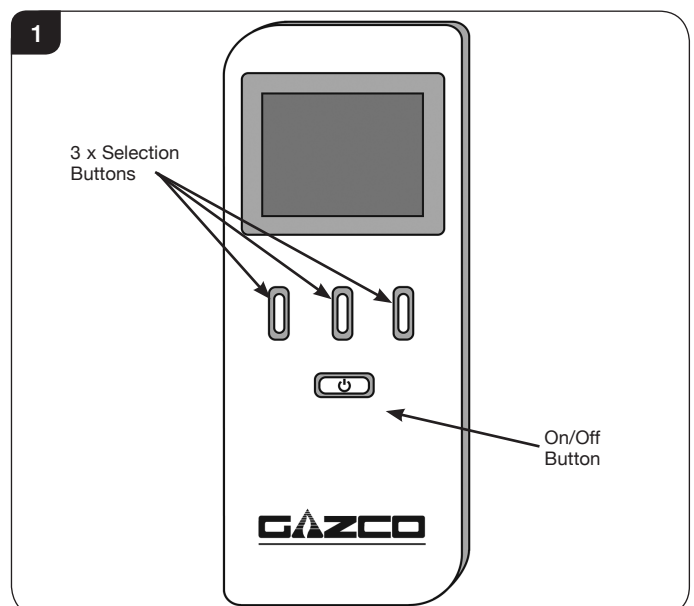

User Instructions

Before using the remote control:

- 2.4 If there is no display on the LCD screen press any key.
- 2.5 When first powered, the handset displays the OFF screen. The handset may be locked as indicated by the padlock symbol (🔒), see Diagram 2.

NOTE: To select a function from the options displayed at the bottom of the screen press the button directly below the desired function.

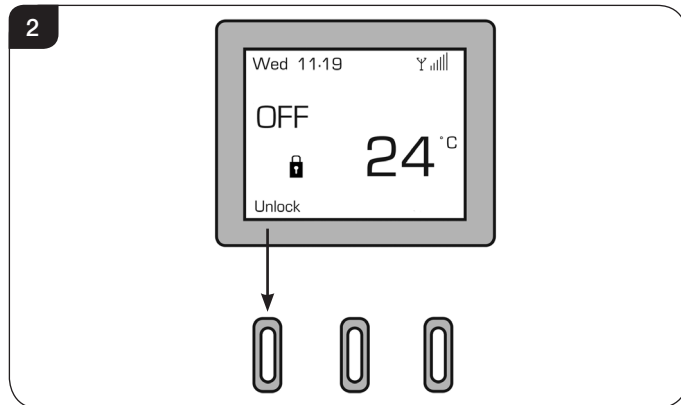

- 2.6 To unlock the handset select Unlock followed by OK - the symbol will change to an open padlock (🔓).
- 2.7 There are 3 different modes available for controlling and operating the appliance:
 1. Manual Mode - See Page 6.
 2. Automatic Mode - See Page 6.
 3. Program Mode - See Page 7.

When a command from the handset is received a beep will sound and the LED on the handset will briefly illuminate.

NOTE: The LED flashes every 4 seconds to show that it is communicating with the appliance. After each command has been accepted the LED will cease flashing until the command has been carried out. Wait until the LED resumes flashing before giving another command.

Advanced Controls

- 2.8 The thermostatic remote control handset has been pre-set as follows:
 - a) Thermostat mode - the appliance will alter automatically to achieve and maintain a desired room temperature in Auto (Fixed Temp) or Program mode.
 - b) Gap temperature set at 2°C - in Auto or Program mode the appliance will automatically ignite if the room temperature falls 2°C below the fixed temperature.
 - c) Program mode enabled - this allows one of three temperatures (Night temperature, Comfort temperature or Off) to be set for each hour of the day on a daily or weekly cycle.

- d) Soft start enabled - in Auto or Program mode there is a 10 second delay between flame settings when more than one change of setting is required (i.e. from High to Low).
- e) Sounder ON - the appliance will beep to confirm that it has received a command from the handset or touch pad.
- f) Safety Temperature pre-set at 40°C - the appliance will automatically switch off if the room temperature (as displayed on the handset) exceeds 40°C.

NOTE: If the Safety Temperature is exceeded the appliance can not be turned on again until the room temperature has dropped below the safety temperature.

- 2.9 The LCD screen displays the following information, see Diagram 3.
 - 1) Time (24 hr clock)
 - 2) Signal strength (between handset and appliance)
 - 3) Selected Setting - set fixed temperature (in degrees) when in Auto mode (small number)
 - 4) Current room temperature (large number)
 - 5) Button function
 - 6) Child lock status (shown by open or closed padlock)
 - 7) Current flame status (Low, Med, High)
 - 8) Selected Mode - Manual Flame / Fixed Temp (Auto) / Program - when appliance is switched on
 - 9) Day of the week (Mon - Sun)

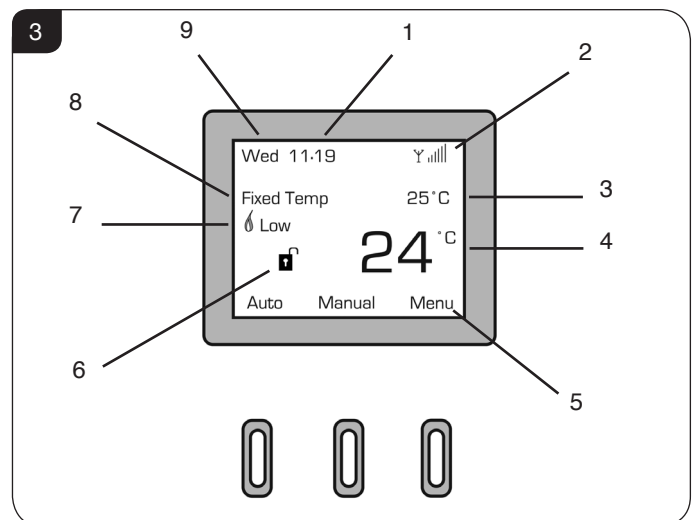

1. Manual Mode

Switching the Appliance ON:

- 2.10 To light the appliance press the On/Off (🔌) button, this will bring up the LCD screen. Select the 'On' option on the left of the screen immediately followed directly by the OK button, a single beep will sound.

User Instructions

After the start up cycle has completed the appliance will light on the high flame setting (this can take up to 20 seconds).

Select the 'Manual' option on the screen to control the appliance.

Decreasing the Flame Height:

- 2.11 From the high flame setting press DOWN (↓) once to lower the flame to the medium setting.
- 2.12 From the medium flame setting press DOWN (↓) once to lower the flame to the low setting.
- 2.13 From the low flame setting press DOWN (↓) once to put the appliance in Standby mode (Pilot only).

Increasing the Flame Height:

- 2.14 To light the appliance when it is in Standby mode press UP (↑) once. The appliance will light on the **Low** flame setting.
- 2.15 From the low setting press UP (↑) once to increase the flame setting to medium.
- 2.16 From the medium setting press UP (↑) once to increase the flame setting to high.



WARNING: IF THE APPLIANCE FAILS TO LIGHT OR BECOMES EXTINGUISHED IN USE, WAIT 3 MINUTES BEFORE ATTEMPTING TO RELIGHT.



IMPORTANT: YELLOW FLAMES TYPICALLY APPEAR WHEN THE APPLIANCE HAS REACHED NORMAL OPERATING TEMPERATURE. THIS CAN TAKE UP TO 30 MINUTES.

Switching the Appliance OFF:

- 2.17 To switch the appliance OFF press the On/Off (⏻) button once, see Diagram 1.

2. Automatic Mode

Auto mode allows you to pre-set a room temperature. The appliance controls the flame setting automatically to achieve and maintain this temperature.

NOTE: WHEN IN AUTOMATIC MODE, THE PILOT REMAINS LIT AND THE MAIN BURNER AUTOMATICALLY ADJUSTS TO MAINTAIN THE FIXED TEMPERATURE WHETHER OR NOT ANYONE IS IN THE ROOM.

- 2.18 If the appliance is switched off, select On followed by OK. The appliance will emit a single beep and the pilot will light.
- 2.19 Select Auto. The screen will display the word 'Thermo' and the current fixed room temperature will be highlighted.
- 2.20 Use the buttons directly below the up (↑) or down (↓) symbols to select a temperature between 0°C and 37°C.

The flame setting required to achieve the desired room temperature will now be displayed below the word 'Thermo'.

2.21 The appliance will maintain the fixed temperature by automatically adjusting the flame height as follows:

- a) If the room temperature falls 1°C below the fixed temperature the flame height will increase.
- b) If the room temperature rises 1°C above the fixed temperature the flame height will decrease.
- c) There will be a delay of 10 seconds between each flame setting adjustment.

2.22 Once the desired room temperature has been set, select Back to return to the main screen.

2.23 The screen will now display the words 'Fixed Temp', the chosen fixed temperature (e.g. 25°C) and the current room temperature (e.g. 24°C), see Diagram 4.

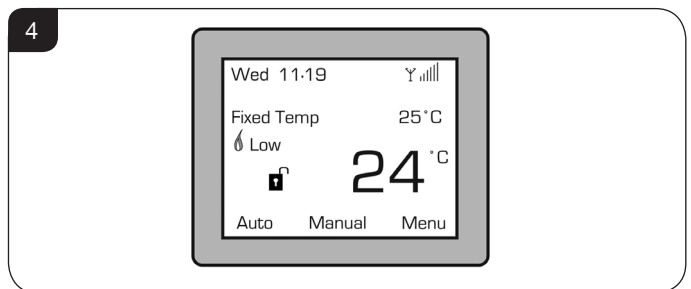

- 2.24 To change the fixed temperature at any time select Auto and follow 2.20.
- 2.25 To exit the Auto mode at any time select Manual and follow Section 2.22.
- 2.26 To turn off the appliance press the ON/OFF button once, see Diagram 2.

Setting the Display

Items displayed on the main screen, such as day and time, can be set using the Adjust Menu function.

- 2.27 To access the Adjust Menu function select Menu from the main screen.
- 2.28 Select Adjust Menu.
In this menu it is possible to set the:
 - Temperature Unit (°C/°F)
 - Language
 - Autolock (On/Off)
 - Day (Mon - Sun)
 - Hour (24hr clock)
 - Minute
 - Comfort temperature (for use when in Program mode)
 - Night temperature (for use when in Program mode)

Access can be gained to the programmable functions via the Change Prog option (see Programming the Appliance).

Setting the Day and Time:

- 2.29 Use (↓) to scroll down to Day and press Select. Use (↑) and (↓) to set the day of the week.

User Instructions

- 2.30 Press Back and scroll down to Hour and select it. Use (↑) and (↓) to set the hour.
- 2.31 Press Back and scroll down to Minute and press Select. Use (↑) and (↓) to set the minutes.
- 2.32 The same process can be used to set any of the functions within this menu.

3. Program Mode

Program mode allows the appliance to be pre-set to a choice of temperature options on a daily or weekly cycle. The appliance will automatically switch on and off and control the flame setting to maintain pre-set hourly temperatures during each 24hr period.

NOTE: WHEN IN PROGRAM MODE, THE PILOT REMAINS LIT AND THE MAIN BURNER AUTOMATICALLY SWITCHES ON AT THE PROGRAMMED TIMES AND ADJUSTS THE FLAME HEIGHT TO BRING THE ROOM TO THE SET TEMPERATURE WHETHER OR NOT ANYONE IS IN THE ROOM.

Note: The current day and time must be set in order for the programmable functions to work. (See Section 2.28 for details).

- 2.33 There are two types of program mode:
 1. Daily - the temperature can be set for each hour over a 24hr period - This pattern is then repeated every day.
 2. Weekly - the temperature can be set for each hour over a 24hr period for each individual day of the week (Mon - Sun). This pattern is then repeated every week.
- 2.34 One of 3 options can be chosen for each hour across a 24 hour period:
 - Off - the appliance will remain in Standby mode (pilot only). **The appliance will not switch off completely when in Program mode.**
 - Night Temp - the appliance will automatically maintain a pre-set night temperature.
 - l Comfort Temp - the appliance will automatically maintain a pre-set comfort temperature.
- 2.35 To set the Comfort and Night temperature select Menu. In the next screen select Adjust Menu. Using (↓) scroll to Comfort Temperature and select. Use (↑) and (↓) to set a chosen temperature. Repeat for Night Temperature.
- 2.36 To access the programming screen select Menu. In the next screen select Adjust Menu. Using (↓) scroll to Change Prog and select. The programming screen will be displayed as shown in Diagram 5.

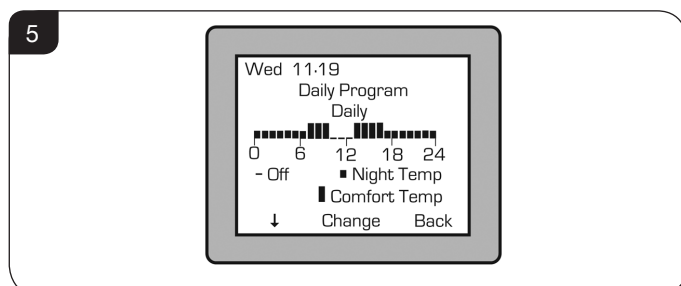

Setting Daily Operating Times:

- 2.37 In the program menu highlight the word 'Daily'. Press (↓) to access the 24 hour timer below 'Daily'. The arrow should now point to the right (→).
- 2.38 The timer reads 0 - 24 with both 0 and 24 representing midnight. Press (→) to scroll through the 24 hour timer. With the cursor resting on the chosen hour, press Change until the desired setting for that hour (Comfort Temperature, Night Temperature or Off) is reached. Use (→) to scroll to the next hour and select the desired function for each hour until all 24 hours are set, see Diagram 6.

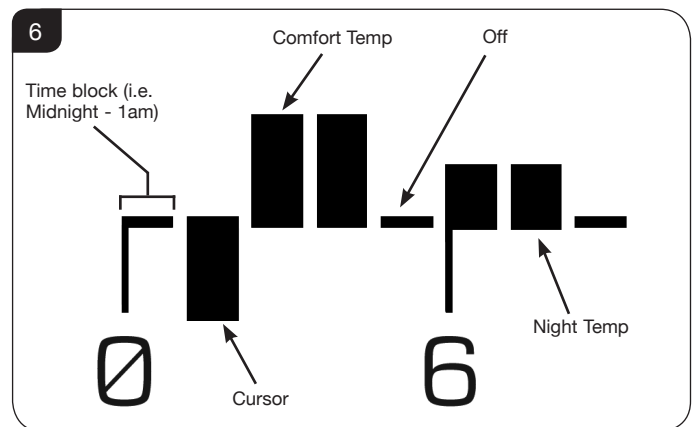

- 2.39 The program must now be launched. To do to this see Section 2.44.

Setting Weekly Operating Times:

- 2.40 Access the programming screen as detailed in Section 2.36. The word 'Daily' will be highlighted. Select 'Change' to scroll from 'Daily' to the required day of the week (Monday - Sunday).
- 2.41 Press (↓) to access the timer. Select the function settings for each hour of the chosen day as detailed in 2.40. Repeat for the rest of the week.
- 2.42 Once the programming is completed select Back to return to the main screen.
- 2.43 The program must now be launched. To do to this see 2.44.

Launching a Daily or Weekly Program:

- 2.44 Select Menu. In the next screen use (↓) to scroll to Program and confirm. Select Change until the highlighted text reads ON.

Note: The appliance must be ON (pilot lit or any flame setting) in order to launch the program.

- 2.45 Select Back and use (↓) to select Prog Type. Select Change until the desired program (Daily or Weekly) is highlighted. Select Back twice to return to the main screen.

User Instructions

To Switch Off Program Mode

- 2.46 To switch off the set program select Stop from the options on the main screen. The appliance will switch to Stand-by (pilot only). Alternatively select Auto; this will end the program cycle and return to the main screen. The appliance will automatically adjust the flame height to maintain any previously set Fixed Temperature.

Locking the Handset

- 2.47 To lock the handset Select Lock. If the option is not visible on the screen (i.e. when the appliance is lit) select Menu and scroll down to Lock. Press Select and use the Change function to scroll to Yes. The handset is now locked.

3. Replacing the Handset Batteries

- 3.1 **BEFORE USE:**
Ensure the remote handset contains 2 x AA 1.5v alkaline batteries (provided). Always replace the batteries with high quality batteries (Duracell or similar).
DO NOT USE RECHARGEABLE BATTERIES.
- 3.2 Communication between the handset and the appliance may take up to 2 minutes after batteries have been replaced, check the strength of the signal in the top right hand corner of the LCD display (Y,||||).
- 3.3 If communication is not regained after this time the control unit and the handset may need pairing. Please refer to Commissioning, Section 2, Pairing the Appliance.

4. Handset Troubleshooting



IMPORTANT - THE CONTROL SYSTEM HAS BEEN PROGRAMMED TO CHANNEL 'C'. SOME HOUSEHOLD APPLIANCES MAY HAVE ALSO BEEN SET TO OPERATE ON THE SAME FREQUENCY. ALTHOUGH THIS HAS NO EFFECT ON THE SAFETY OF THE SYSTEM AN EXCESSIVE DELAY MAY BE ENCOUNTERED BETWEEN COMMANDS. IF THIS OCCURS FOLLOW THE INSTRUCTIONS IN COMMISSIONING SECTION 3 TO CHANGE THE CHANNEL.

CHANNEL SETTINGS

- 4.1 The appliance has been factory set to only communicate with the handset it is supplied with. It will not respond to any other remote control, even one from an identical appliance.

A replacement handset will need to be paired with the appliance before use. Please refer to Commissioning, Section 2, Pairing the Appliance.

LOW BATTERY

- 4.2 If the batteries in the remote control handset become discharged the LCD display will show the message Low Battery.

Follow Section 3 - Replacing The Handset Batteries.

REMOTE SIGNAL STRENGTH



NOTE: If the handset is taken out of range the signal strength indicator will show 'Loss of Signal'. When the handset is returned to the appliance it will be necessary to press any button and wait for the signal indicator to recognise the handset. This can take up to 4 minutes

- 4.3 If the appliance does not respond to the handset, check the strength of the signal in the top right hand corner of the LCD display (Y,||||).

No vertical bars next to the signal symbol (Y) means communication between the appliance and the handset has been lost. If the communication loss exceeds 18 minutes the appliance will emit 20 beeps and switch OFF. Try the following:

- 4.4 Move the handset closer to the appliance.
- 4.5 Replace the batteries in the handset, see Section 3.
- 4.6 If there is still no signal, operate the appliance using the touch pad control, see Section 5 and consult your installer or Gazco retailer.

5. Touch Pad Control

7

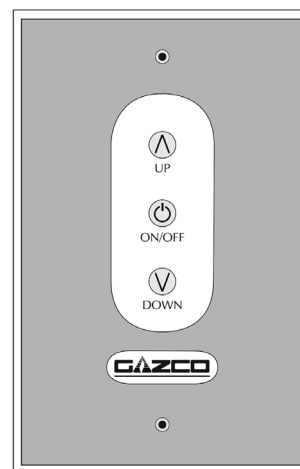

The touch pad control is located on the front of the wall switch and allows manual operation of the appliance, see Diagram 7.

With the touch pad it is possible to turn the appliance ON, OFF and control the flame setting.

NOTE: When using the touch pad buttons a beep will be emitted from the appliance to indicate an accepted command.

Lighting the appliance

- 5.1 Press the On/Off button once.

If the pilot fails to light, press the ON/OFF button to switch OFF. Wait for at least 30 seconds before attempting to relight.

User Instructions

5.2 After the start up cycle has completed the appliance will light on the **high flame setting** (this can take up to 20 seconds).

If the appliance is in Standby mode, pressing the UP (^) button will cause the main burner to ignite on the **Low** flame setting.

5.3 To increase the flame height press the UP (^) button.

5.4 To decrease the flame height press the DOWN (v) button.

5.5 When on the lowest flame setting pressing the Down (v) button will switch the appliance to Standby mode (pilot only).



WARNING: IF THE APPLIANCE FAILS TO LIGHT OR BECOMES EXTINGUISHED IN USE, WAIT 3 MINUTES BEFORE ATTEMPTING TO RELIGHT.



IMPORTANT: YELLOW FLAMES TYPICALLY APPEAR WHEN THE APPLIANCE HAS REACHED NORMAL OPERATING TEMPERATURE. THIS CAN TAKE UP TO 30 MINUTES.

To Switch the Appliance OFF:

5.6 To turn the appliance **OFF** press the On/Off button once.

Touch Pad Control Not Working

If the appliance is not operating with the touch pad control:

5.7 Replace the batteries in the wall switch unit, see Section 6.

5.8 If the appliance still fails to operate consult your installer or Gazco retailer.

6. Changing the Appliance Batteries

The appliance batteries are located behind the wall switch plate.

6.1 Undo the two screws securing the wall plate and gently bring it forward to expose the wires behind. Keep the wall plate supported, taking care not to put any strain on the wires, see Diagram 8.

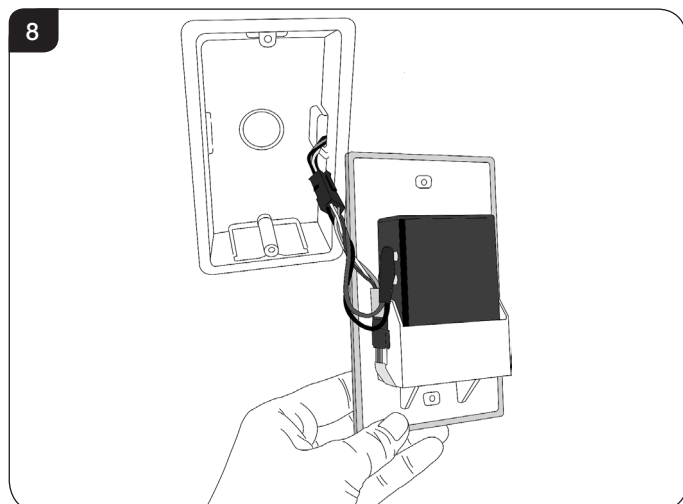

6.2 Whilst supporting the wall plate remove the battery holder from its location, see Diagram 9.

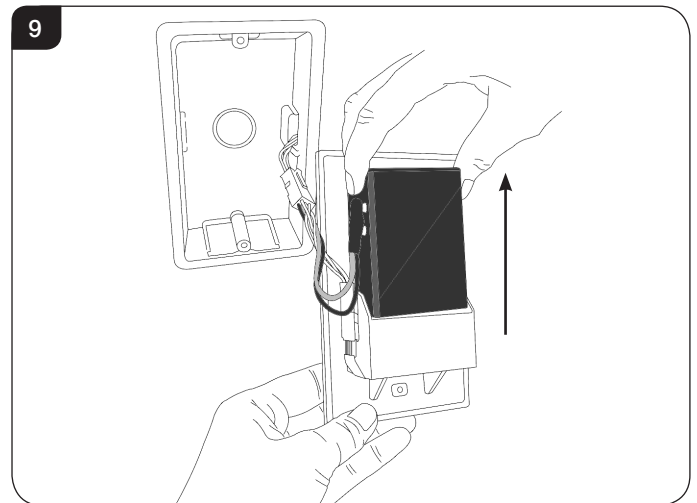

6.3 If it is not possible to support the wall plate and battery holder at the same time separate the wall plate from the dry lining box by disconnecting the plug as shown, see Diagram 10. Press the top of the clip on the upper section to release.

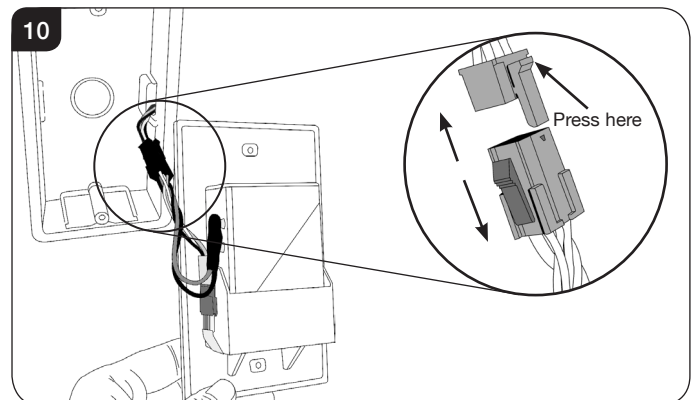

6.4 Flip the battery holder over end to end and remove the cover by sliding off in the direction of the arrow as shown in, see Diagram 11.

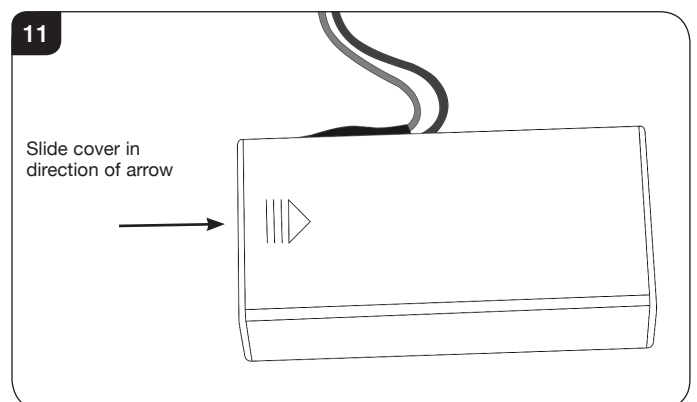

User Instructions

- 6.5 Remove the old batteries and correctly position the three new high quality (Duracell or similar) size C batteries into the battery holder, see Diagram 12.

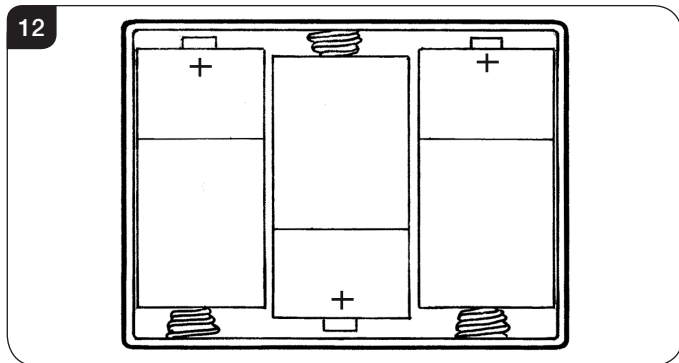

- 6.6 Re-assemble in reverse.

PLEASE ENSURE NO WIRES ARE TRAPPED BEFORE REPLACING THE WALL PLATE. THE TOUCH PAD LEAD IS EASILY DAMAGED.

7. Cleaning the Appliance

- 7.1 Make sure the appliance and surrounds are cool before cleaning.
- 7.2 If a decorative front has been fitted to the appliance, please remove by referring to the separate instructions supplied.
- 7.3 Remove the glass frame by removing the 2 side trims, see Diagram 13. These are held on by magnets.

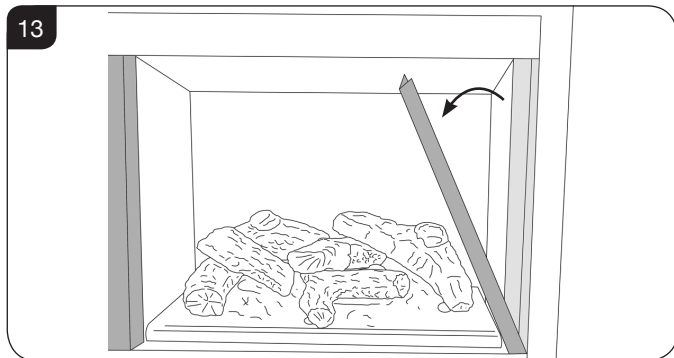

- 7.4 Lift out the bottom slotted trim, see Diagram 14. Note the orientation of the metal shield for reassembly.

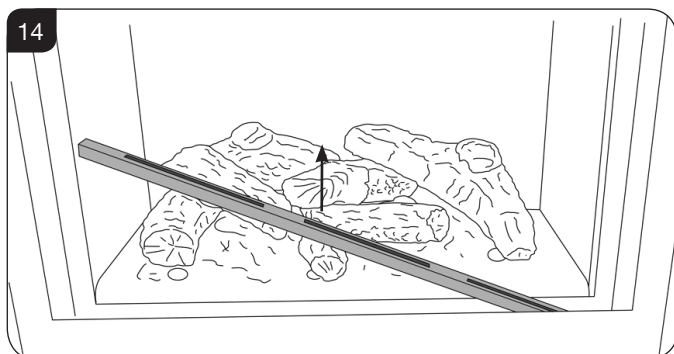

- 7.5 Remove the 2 screws at the base of the door, see Diagram 15.

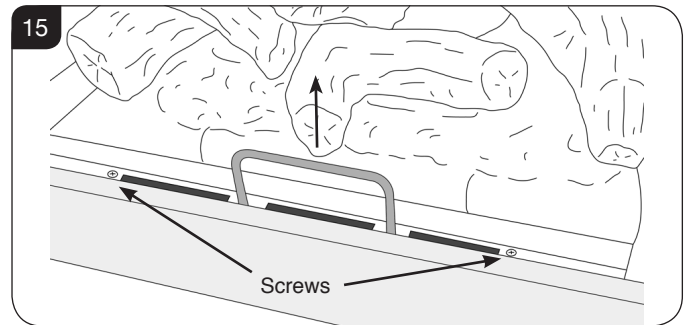

- 7.6 Pull up the handle at the front, see Diagram 15.
- 7.7 Whilst supporting the top, lift the door using the handle, up and over the lower edge, see Diagram 16.

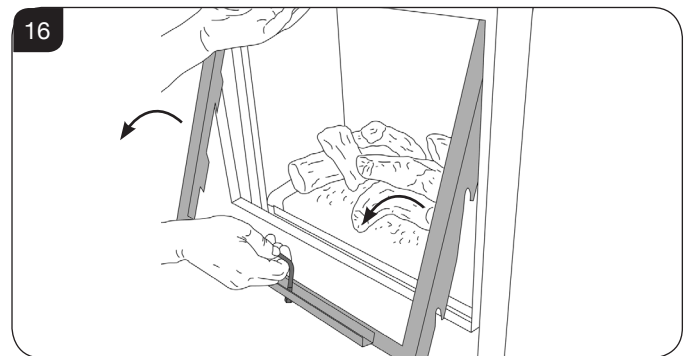

- 7.8 Remove the logs, and place them on a dry, clean surface.
- 7.9 The logs should not require cleaning. Do not use a vacuum cleaner or brush to clean the logs, any large pieces of debris may be removed by hand.
- 7.10 Ensure any debris is removed from the burner ports.
- 7.11 Use a damp cloth to clean the outer casing of the appliance.
- 7.12 To clean the glass surface use a non abrasive glass cleaner and soft cloth.
- 7.13 The glass frame must be refitted to the appliance following cleaning or servicing.

Ensure that the fibreglass seal on the back of the glass frame is intact.

- 7.14 To replace the glass frame, position so the hooks on the back of the frame fit over the side pins, see Diagram 17.

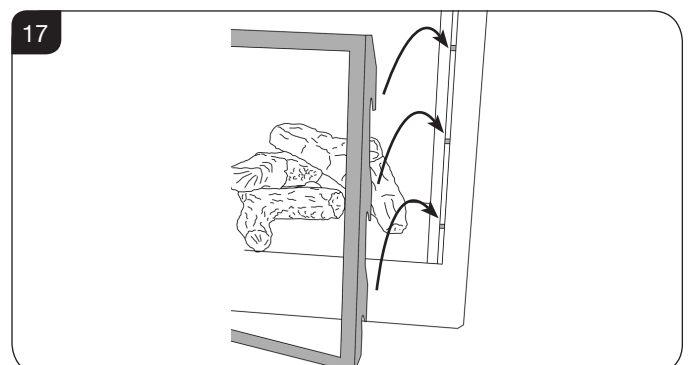

User Instructions

- 7.15 Push the handle down.
- 7.16 Replace the screws. As the screws are tightened the glass frame is pulled down against the hooks and forms a seal. **Replace ALL of the securing screws ensuring that a screw is present in all fixing slots.**



UNDER NO CIRCUMSTANCES SHOULD THE APPLIANCE BE USED IF ANY OF THE GLASS FRAME RETAINING SCREWS ARE LOOSE OR MISSING.

- 7.17 Replace the lower trim, ensuring that the angled metal shield is sloping towards the door frame.
- 7.18 Replace the 2 magnetic side trims.

NEVER OPERATE THE APPLIANCE WHEN THE GLASS PANEL IS REMOVED OR BROKEN.

- 7.19 Replace the decorative front by referring to the separate instructions supplied with the front.

NOTE: ENSURE THAT THE LOGS ARE POSITIONED CORRECTLY, SEE SECTION 8. ONLY USE THE CORRECT AMOUNT OF LOGS AS SPECIFIED IN THE DIAGRAMS.

Advice on handling and disposal of fire ceramics



The side panels in this appliance are made from **Refractory Ceramic Fibre (RCF)**, a material which is commonly used for this application.

Protective clothing is not required when handling these articles, but we recommend you follow normal hygiene rules of not smoking, eating or drinking in the work area and always wash your hands before eating or drinking.

To ensure that the release of RCF fibres are kept to a minimum, during installation and servicing a HEPA filtered vacuum is recommended to remove any dust accumulated in and around the appliance before and after working on it. When servicing the appliance it is recommended that the replaced items are not broken up, but are sealed within heavy duty polythene bags and labelled as RCF waste.

RCF waste is classed as stable, non-reactive hazardous waste and may be disposed of at a licensed landfill site.

Excessive exposure to these materials may cause temporary irritation to eyes, skin and respiratory tract; wash hands thoroughly after handling the material.

8. Arrangement of Fuel Bed Components

LOGS MUST BE POSITIONED ACCORDING TO THE FOLLOWING INSTRUCTIONS TO GIVE THE CORRECT FLAME EFFECT.

- 8.1 Ensure the burner tray is clean and free from any debris.
- 8.2 The logs for the fuel bed are clearly individually labelled, see Diagram 18.

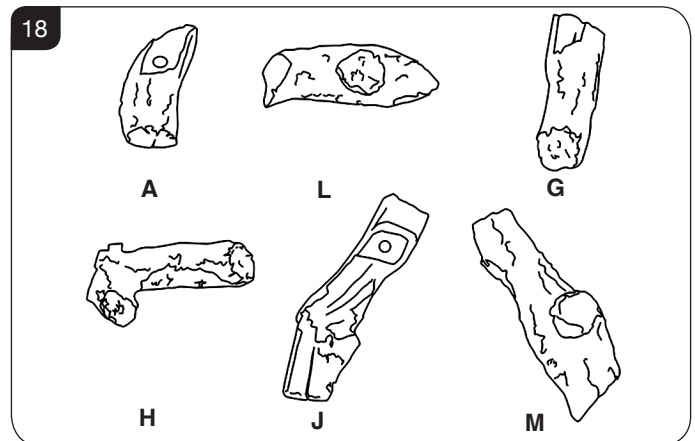

- 8.3 Place log A on the left hand front of the burner. The log will fit over the raised stud and into the groove in the burner tray, see Diagram 19.

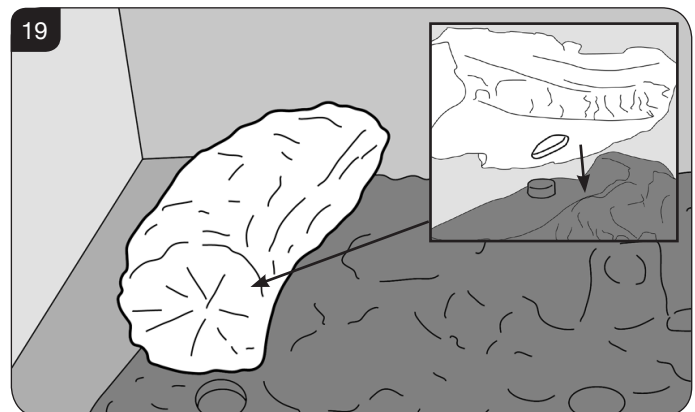

- 8.4 Place Log L behind the Log A on the flat plain and locate the rear of the log on the metal bracket. The log should rest between the lip of the bracket and the rear liner, see Diagram 20.

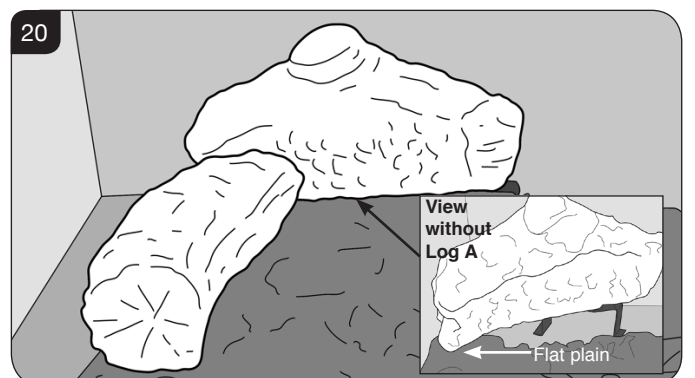

User Instructions

- 8.5 Place Log G on top of Log A. There is a hole on the underside of Log G which fits over the raised stud on Log A to secure in place. The end of the log sits on the raised section of the burner tray, see Diagram 21.

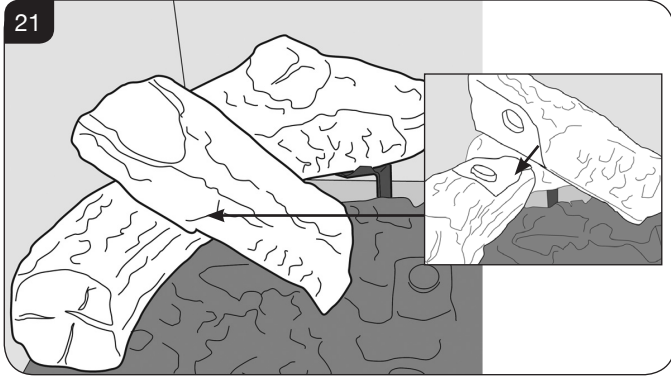

- 8.6 Place Log H on the centre of the burner tray. There is a raised stud in the fuel bed which securely locates the log in place. The right hand side rests on the raised section at the end of the air cutout, see Diagram 22.

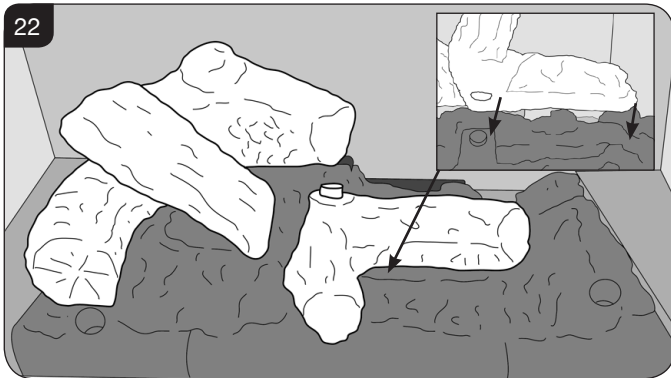

- 8.7 Rest Log J on the raised stud on Log H. The rear of the effect should rest on the metal bracket at the back of the burner tray, see Diagram 23.

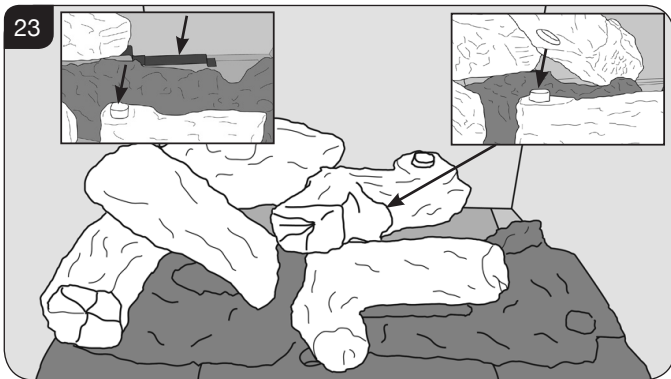

- 8.8 Sit the first hole in the bottom of the left hand side of Log M on the stud of Log H and secure by fitting the middle hole on the right hand side over the stud in the fuel bed by the burner port, see Diagram 24.

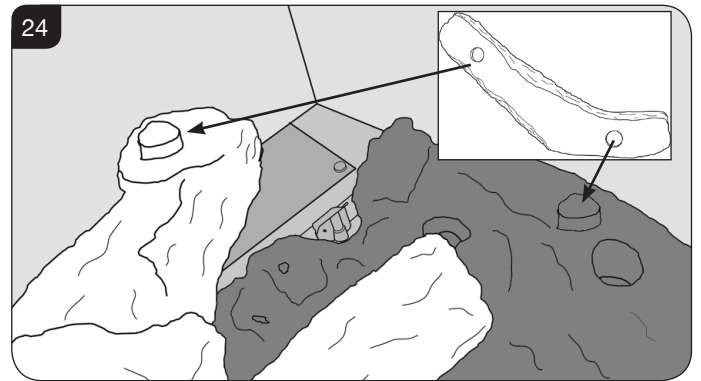

- 8.9 Log M should rest on the flat plain behind the stud for the Log arrangement to be complete, see Diagram 25.

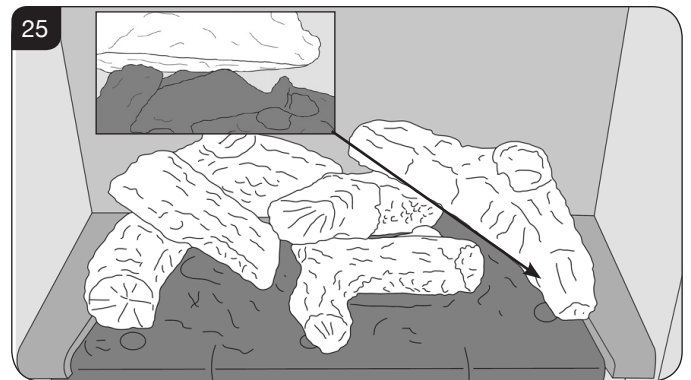

- 8.10 Place the small pieces of bark down either side, see Diagram 26.

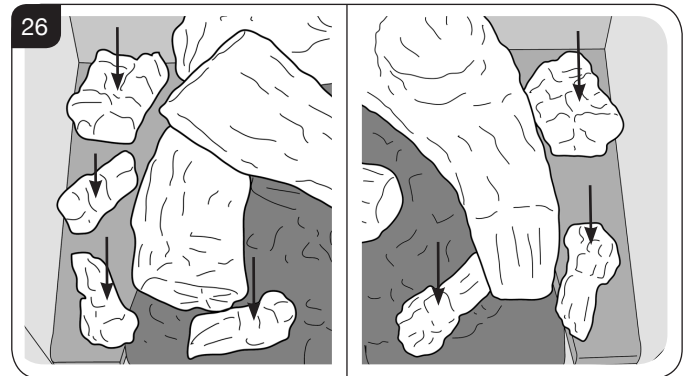

- 8.11 Lay emberglow over the small ports in the base of the burner tray. This will create a glowing effect when the appliance is lit, see Diagram 27.

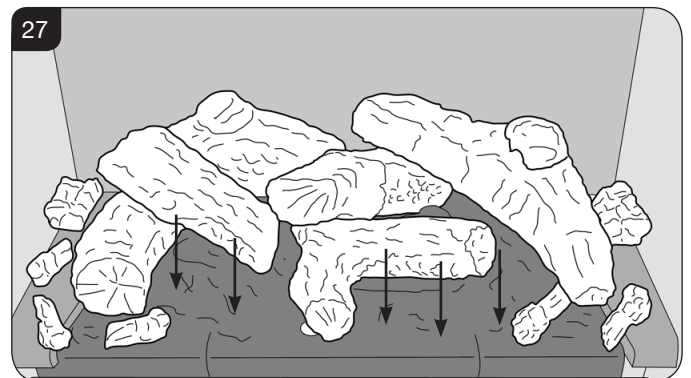

User Instructions

10. Oxygen Depletion Sensor

The appliance is fitted with an oxygen sensitive pilot system that will act to cut off the gas supply to the appliance should the oxygen in the room fall below its normal level. If the appliance is turned off by this device it usually indicates that there is a problem with the flue system, this should be inspected by a qualified engineer.

DO NOT ATTEMPT TO USE THE APPLIANCE UNTIL AN ENGINEER SAYS IT IS SAFE TO DO SO. THIS DEVICE IS NOT A SUBSTITUTE FOR AN INDEPENDENTLY MOUNTED CARBON MONOXIDE DETECTOR.

11. Flame Failure Device

- 11.1 This is a safety feature incorporated on this appliance which automatically switches off the gas supply if the pilot goes out and fails to heat the thermocouple.

IF THIS OCCURS DO NOT ATTEMPT TO RELIGHT THE APPLIANCE FOR 3 MINUTES.

12. Running In

- 12.1 During initial use of a new Gazco appliance a strong odour will be encountered as various surface coatings become hot for the first time. Although these odours are harmless it is recommended that the appliance is operated on maximum for 4 to 8 hours in order to fully burn off these coatings. After this period the odours should then disappear.

If the odours persists, please contact your installer for advice.

- 12.2 During the first few hours of burning there may be discolouration of the flames. This will also disappear after a short period of use.

13. Servicing

- 13.1 The appliance must be serviced every 12 months by a qualified Gas Engineer. In all correspondence always quote the Model number and the Serial number which may be found on the data badge.

14. Ventilation

- 14.1 Any purpose provided ventilation should be checked periodically to ensure that it is free from obstruction.

15. Installation Details

- 15.1 Your installer should have completed the commissioning sheet at the front of this book. This records the essential installation details of the appliance. In all correspondence always quote the Model number and Serial number.

16. Hot Surfaces

- 16.1 Parts of this appliance become hot during normal use.
16.2 Regard all parts of the appliance as a working surface.
16.3 Provide a suitable fire guard to protect young children and the infirm.

28

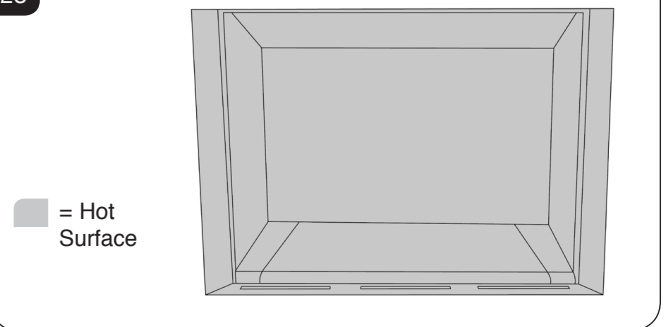

17. Appliance will not light

If you cannot light the appliance:

- 17.1 Check and change the batteries in the remote handset.
17.2 Check and change the wall touchpad batteries (see Section 6).
17.3 Consult your Gazco retailer or installer if the Riva2 500 still does not light.

Installation Instructions

Technical Specification

Covering the following models:

Riva2 500 Nat Gas	Riva2 500 LPG
134-204	134-451

Model	Gas CAT.	Gas Type	Working Pressure	Aeration	Injector	Gas Rate m ³ /h	Input kW (Gross)		Country
							High	Low	
Riva2 500	I ₂ H	Natural (G20)	20mb	2x 6mm Ø	375	0.610	6.4	3.9	GB, IE
Riva2 500	I ₃ P	Propane (G31)	37mb	2 x 14mm Ø	128	0.241	6.4	3.7	GB, IE
Efficiency Class 2 - 76% / NO_x Class 4									
Flue Size - TOP EXIT Ø 127mm									
Flue Size - REAR EXIT 178mm ø minimum									
Gas Inlet Connection Size Ø 8mm									
Minimum Flue Specification = T260/N2/0/D/1									
Maximum Flue Temp = 220°C									

This appliance has been certified for use in countries other than those stated. To install this appliance in these countries, it is essential to obtain the translated instructions and in some cases the appliance will require modification. Contact Gazco for further information.

PACKING CHECKLIST

Qty	Description	Fixing kit containing
1 x	Cassette and burner assembly	1 x Instruction manual
1 x	Back panel	6 x Woodscrews
1 x	LH side panel	6 x Wall plugs
1 x	RH side panel	1 x Self adhesive foam strip
1 x	Log set (6 logs)	2 x AA 1.5 alkaline batteries
		3 x Size C batteries
		1 x Battery Holder
		1 x Touchpad/ Wall Plate

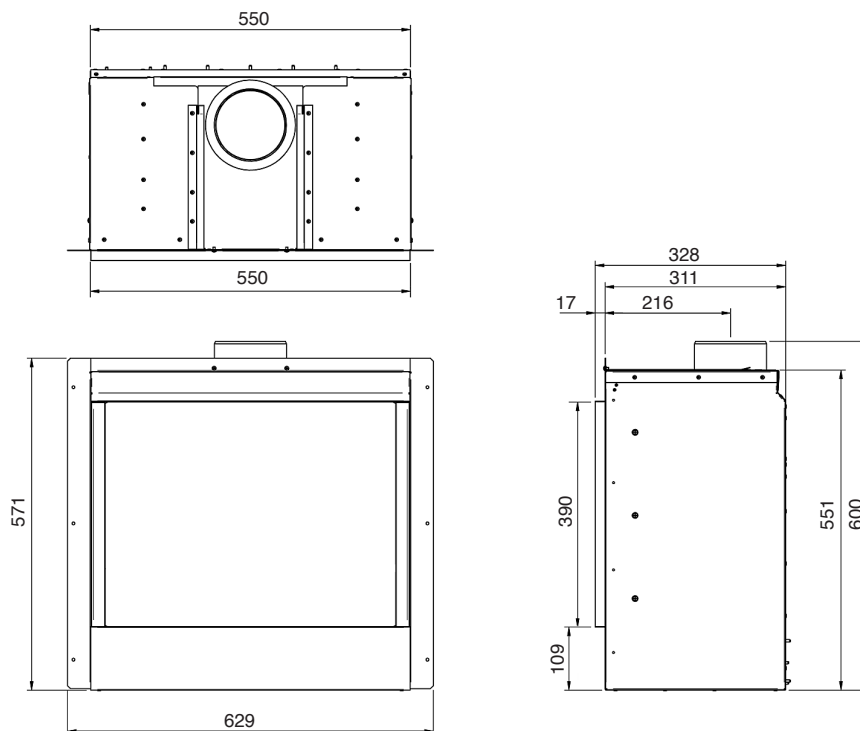

Installation Instructions

Site Requirements

1. Flue & Chimney Requirements

WHEN INSTALLING A FLUE SYSTEM PLEASE REFER TO THE MANUFACTURER'S INSTRUCTIONS.

The European chimney standards now describe chimneys and flues by their temperature, pressure and resistance to corrosion, condensation and fire. To identify the correct flue system, the minimum flue specification is shown in the Technical Specification. Existing chimneys are not covered by this system.

The flue must be installed in accordance with all local and national regulations and the current rules in force:

- 1.1 A flexible liner must be continuous from the appliance spigot to the roof terminal.
- 1.2 The minimum effective height of the flue must be 3m (10').
- 1.3 The flue must be free from any obstruction.
- 1.4 Any damper plates must be removed or secured in the fully open position and no restrictor plates fitted.
- 1.5 The chimney should be swept immediately before installing the appliance, but it need not be swept if you can see the chimney is clean and free from obstruction throughout.

2. Flue Options

There are three main suitable Conventional Flues:

- Top Exit - Builder's Opening Lined
127mm (5")
- Rear Exit - Builder's Opening Unlined
178mm (7") minimum



Note: This appliance has been designed to fit a masonry opening, however a studwork installation is possible if required.

- Stud work is Top Exit only - Twin Wall Rigid
127mm (5")

3. Gas Supply

This appliance is intended for use on a gas installation with a governed meter.

- 3.1 Make sure local distribution conditions (identification of the type of gas and pressure) and the adjustment of the appliance are compatible before installation.
- 3.2 Ensure the gas supply delivers the required amount of gas and is in accordance with the rules in force.
- 3.3 You can use soft copper tubing on the installation and soft soldered joints outside the appliance and below the firebed.

- 3.4 A factory fitted isolation device is part of the inlet connection; no further isolation device is required.
- 3.5 All supply gas pipes must be purged of any debris that may have entered prior to connection to the appliance.
- 3.6 The gas supply enters through the silicone panel located on the LEFT-HAND side of the outer box. Slit with a sharp knife prior to passing the supply pipe through.
- 3.7 The gas supply must be installed in a way that does not restrict the removal of the appliance for servicing and inspection.

4. Ventilation

IMPORTANT: Ensure any national ventilation requirements are taken into account during installation of the appliance.

UK ONLY:

The Riva2 500 has a nominal input not exceeding 7.0kW and does not normally require any additional permanent ventilation.

FOR THE REPUBLIC OF IRELAND REFER TO THE RULES IN FORCE FOR VENTILATION REQUIREMENTS.

5. Appliance Location



Note: This appliance is supplied as an edge installation but it is possible to fit a frame at a later stage without any remedial building work needed. However the appliance must originally be installed a minimum of 150mm above floor level to allow for this.

- 5.1 If this appliance is fitted less than 150mm from the floor, then it will require a hearth to protect the floor. The hearth should have a minimum dimension of 12mm thick, projecting 300mm in front and 150mm either side of the appliance.

The minimum opening dimensions are shown in Diagram 1.

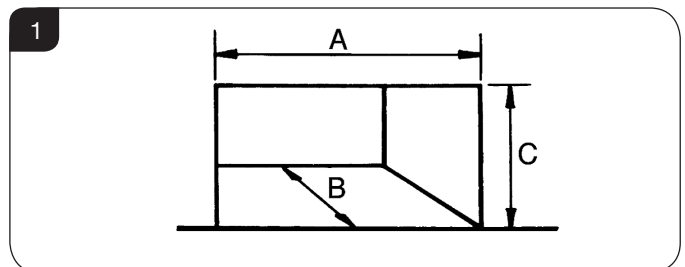

DIMENSION	Riva2 500
A	565
B	350
C	560

Installation Instructions

Site Requirements

- 5.2 This appliance must not be installed in a room that contains a bath or shower.
- 5.3 **NOTE: If using natural materials for the back panel of the fireplace, it is recommended that it is constructed from three or more sections to prevent cracking. Resin-based materials may not be suitable. This appliance is an effective heat producer and attention must be paid to the construction and finish of the fireplace.**
- 5.4 This appliance is not suitable for installation onto a combustible wall; all combustible materials must be removed from the area shown in Diagrams 2.

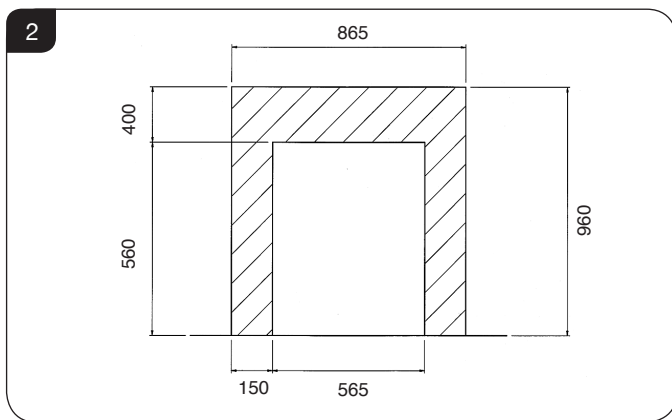

STUDWORK INSTALLATION

- 5.5 If a studwork installation is used (eg. wooden framework and plasterboard), combustible parts of the studwork must not be any closer than the minimum dimensions shown in the diagrams. **NOTE:** These dimensions must be maintained even if the combustible materials is protected by non-combustible linings.
- 5.6 Do not pack the void around or above the appliance with insulation materials such as mineral wool.
- 5.7 The void into which the cassette is fitted must be ventilated to prevent a build up of heat. If the void is sealed then it will be necessary to fit vents at both low and high levels of approximately 50cm² each. These vents should take cold air from the room and return warm air back into the room.
- 5.8 A removable access hatch must be left in the side of the chimney breast for future servicing and inspection of the appliance.
- 5.9 Build the studwork chimney breast to the desired size. Ensure that the clearances to combustible materials is maintained.

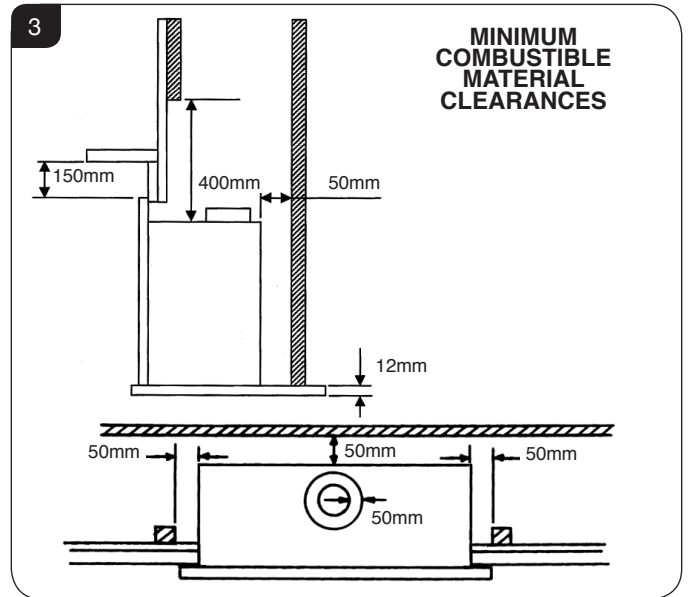

It is recommended that a marble slip or similar material is used when fitting cassette fireplaces into a plastered surface, in order to allow for heat dissipation. Also allow adequate time for newly plastered areas to dry out. Rapid drying can create cracks. If in doubt, seek the advice of a professional plasterer.

Parts of this appliance become hot during normal use. It is therefore recommended that a suitable fire guard be used for protection of young children and the infirm.

Installation Instructions

1. Safety Precautions

- 1.1 For your own and other's safety, you must install this appliance according to local and national codes of practice. Failure to install the appliance correctly could lead to prosecution. **Read these instructions before installing and using this appliance.**
- 1.2 These instructions must be left intact with the user.
- 1.3 Do not attempt to burn rubbish on this appliance.
- 1.4 Keep all plastic bags away from young children.
- 1.5 Do not place any object on or near to the appliance and allow adequate clearance above the appliance.

IF THE APPLIANCE IS EXTINGUISHED OR GOES OUT IN USE, WAIT 3 MINUTES BEFORE ATTEMPTING TO RELIGHT THE APPLIANCE.

- 1.6 The appliance is fitted with an oxygen sensitive pilot that will act to cut off the gas supply to the appliance in the event of incorrect operation of the flue. If the system acts to shut off the gas supply, this indicates that there is insufficient flue pull. Continued operation of this safety device means that there may be a serious problem with the flue system, and this should be inspected by a qualified gas engineer. **Do not use the appliance until an engineer says it is safe to do so.** The oxygen sensitive pilot must not be tampered with. Use only genuine Gazco replacement parts when servicing the appliance - refer to Servicing section.



IMPORTANT: REFER TO DATA BADGE AND TECHNICAL SPECIFICATION AT THE FRONT OF THE MANUAL TO ENSURE THE APPLIANCE IS CORRECTLY ADJUSTED FOR THE GAS TYPE AND CATEGORY APPLICABLE IN THE COUNTRY OF USE.

FOR DETAILS OF CHANGING BETWEEN GAS TYPES REFER TO SERVICING, SECTION 12, REPLACING PARTS.

Unpacking

- 1.7 Remove the appliance from its packaging, and check that it is complete and undamaged.

Put the loose ceramic parts to one side so that they are not damaged during installation.

2. Installation of the Appliance



Note: This appliance has been designed to fit a masonry opening, however a studwork installation is possible if required.

- 2.1 This appliance can be installed in four different ways:
 - 1) Builder's opening with a frame
 - 2) Builder's opening without a frame
 - 3) Stud work with a frame
 - 4) Stud work without a frame



IMPORTANT: NO MATTER IF A FRAME IS TO BE ATTACHED OR NOT, THIS APPLIANCE MUST ALWAYS BE INSTALLED AS AN EDGE FINISH REGARDLESS OF WHETHER IT IS FITTED INTO A MASONRY OR STUDWORK SETTING.

- 2.2 The Riva2 500 is supplied with a flue fixing plate to attach the flue to the appliance within the aperture.
- 2.3 Locate the flue liner in position and place the flue securing clip over the liner, push the end of the liner over the outside of the spigot and secure by tightening the securing clip, see Diagram 1.

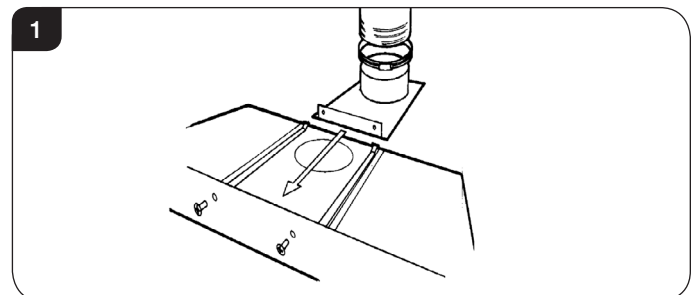

- 2.4 Place the liner in its final position ensuring that the sliding flue plate rests at the correct height in the opening, and that the front flange of the plate rests against the outside face at the top of the opening.
- 2.5 When installing the appliance into a masonry chimney without a liner, it must be converted to a rear exit.
- 2.6 Remove the 2 fixing screws securing the spigot assembly.
- 2.7 Slide the blanking plate into the guides.
- 2.8 Replace the 2 fixing screws, see Diagram 2.

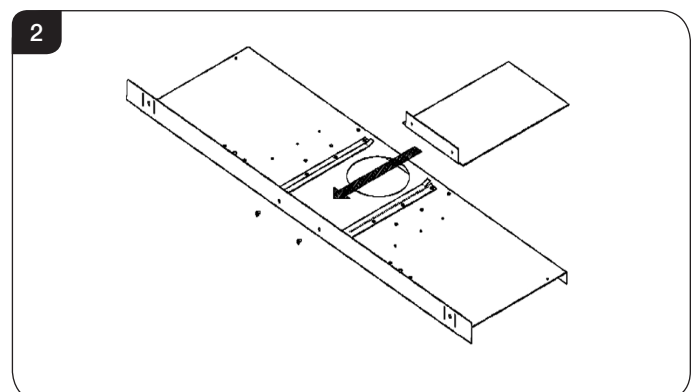

Installation Instructions

The flue must be in good condition and clear products of combustion, see Installation Instructions, Commissioning.

- 2.9 If a flexible liner is to be used check the seal on the inner lip of the spigot plate is intact. Replace if necessary .

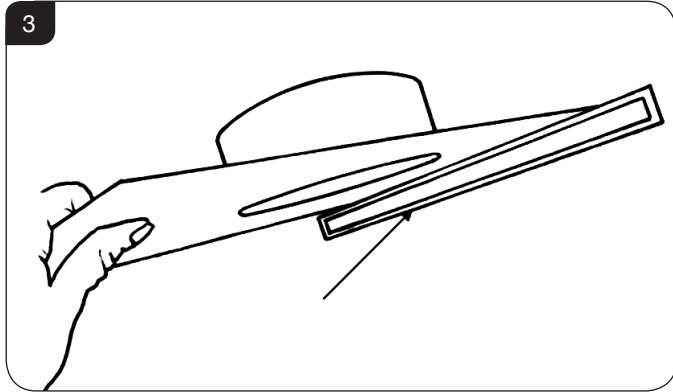

Options 3 and 4 (Studwork with or without a frame) must be fitted using the top exit only with rigid twin wall flue pipe.

- 2.10 **THE APPLIANCE IS SUPPLIED WITH A WALL BOX CONTAINING THE BATTERIES AND TOUCH PAD. THIS MUST BE RECESSED INTO THE WALL WITH ACCESS FOR THE CABLES PRIOR TO FITTING THE APPLIANCE.**

3. Removing the Glass Frame

- 3.1 Remove the glass door by removing the 2 side trims, see Diagram 4. These are held on by magnets.

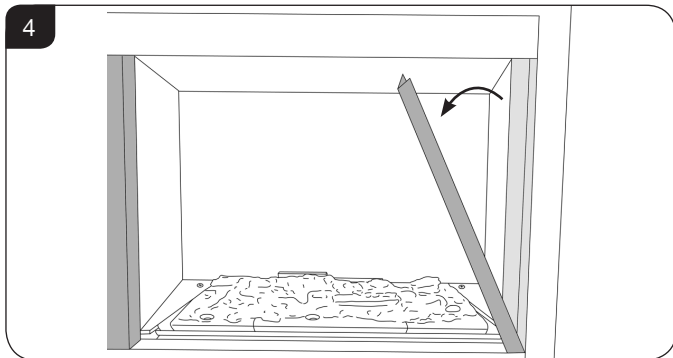

- 3.2 Lift out the bottom slotted trim, see Diagram 5. Note the orientation of the metal shield for reassembly.

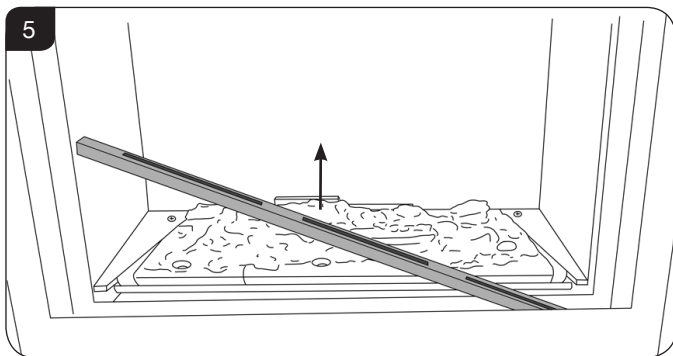

- 3.3 Remove the 2 screws at the base of the door, see Diagram 6.

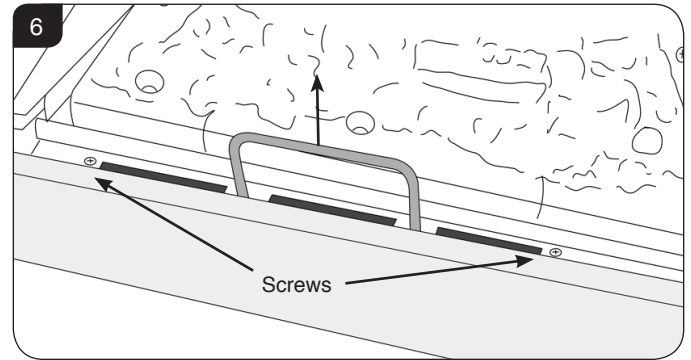

- 3.4 Pull up the handle at the front, see Diagram 6.

- 3.5 Whilst supporting the top, lift the door using the handle, up and over the lower edge, see Diagram 7.

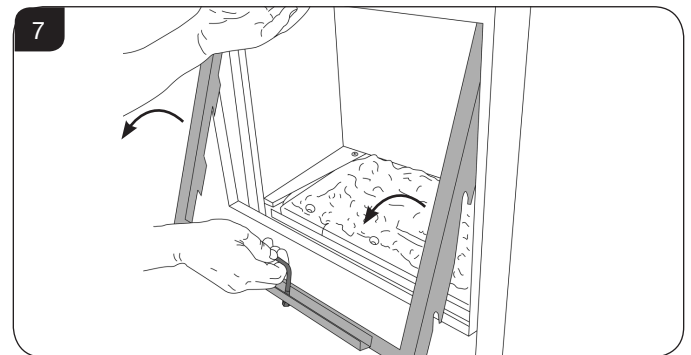

- 3.6 Undo the screws to remove the left hand metal side covers see Diagram 8.

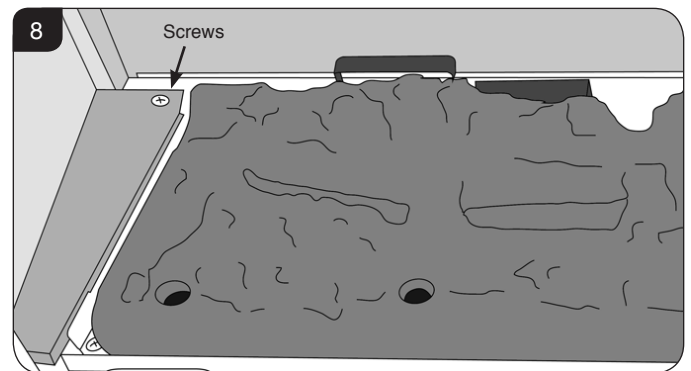

- 3.7 The gas supply enters through the silicone panel located on the left-hand side of the outer box; this will need to be slit with a sharp knife prior to passing the supply pipe and wall panel cable through, see Diagram 9.

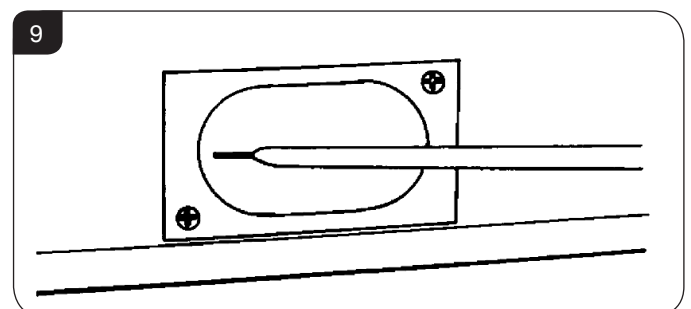

Installation Instructions

Note: The isolation elbow needs to be attached to the gas pipe before installation.

4. All types of Installation - Wall Box & Batteries



Please note: As an optional extra Gazco can provide a mains adapter to supply constant power to the appliance control box instead of the battery pack.

If installing an appliance with the adapter make provision for a mains power socket within 1.5m of the control box and follow the instructions provided.

- 4.1 Decide on the position for the wall box containing the batteries and wall switch.

NOTE:

A combined battery power supply and touch control cable is supplied and pre-fitted to the appliance control. Provision is made for the cable to exit either the left of the appliance through the grommet or the silicon panel at the back. The cable is 3 metres long.

When deciding the route of the cables consideration must be given to avoiding contact with the appliance and the flue system.

- 4.2 Correctly position the three new high quality (Duracell or similar) size C batteries into the battery holder. Replace the cover by sliding it on to the battery holder.

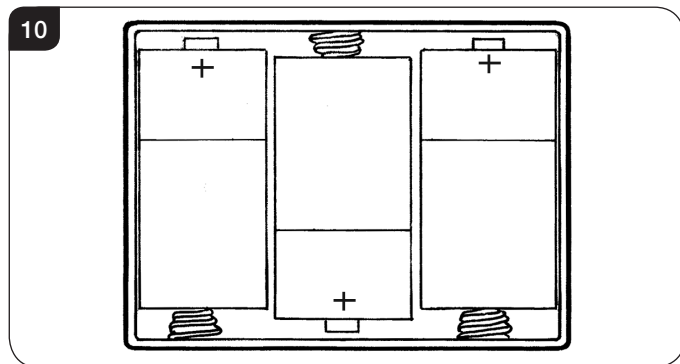

- 4.3 Slide the battery box into its housing in the back of the wall plate, see Diagram 11.

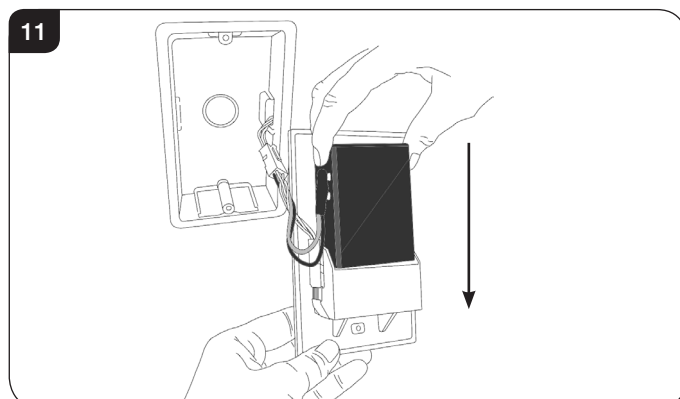

- 4.4 Ensure both sets of wires are connected, see Diagrams 12 & 13. **When replacing the 4 pronged connector ensure that the arrows are aligned.**

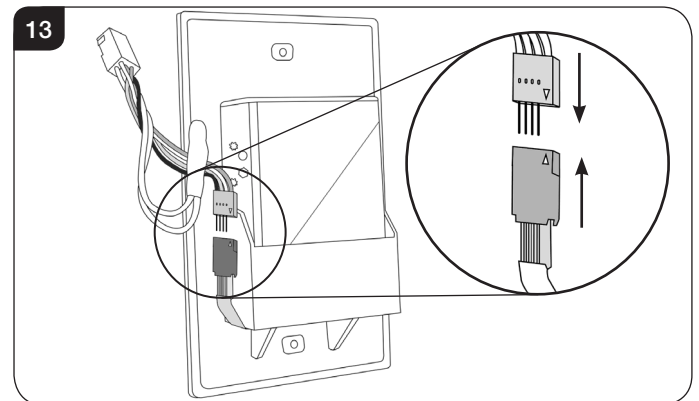
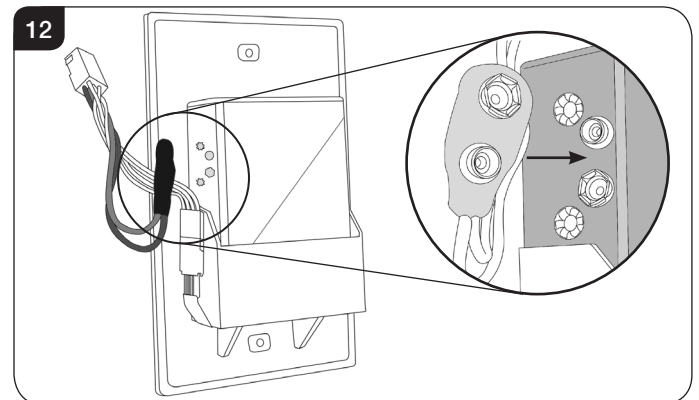

- 4.5 Connect the cable from the appliance to the touch pad cable, see Diagram 14.

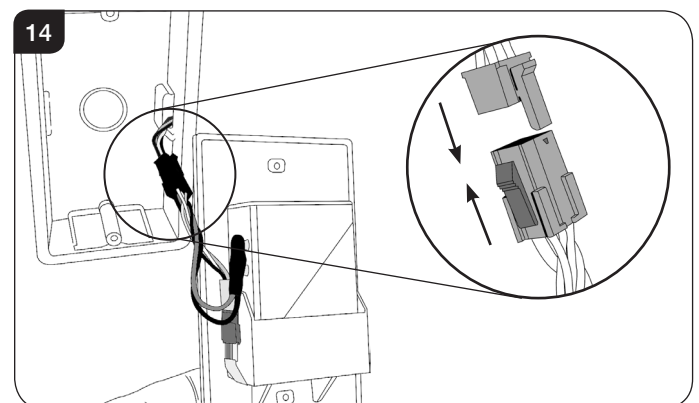

- 4.6 **IMPORTANT: THE WALL SWITCH MUST BE INSTALLED USING THE PLASTIC DRY LINING BOX SUPPLIED.**

Secure the wall plate to the dry lining box with the 2 x screws provided, see Diagram 15.

Installation Instructions

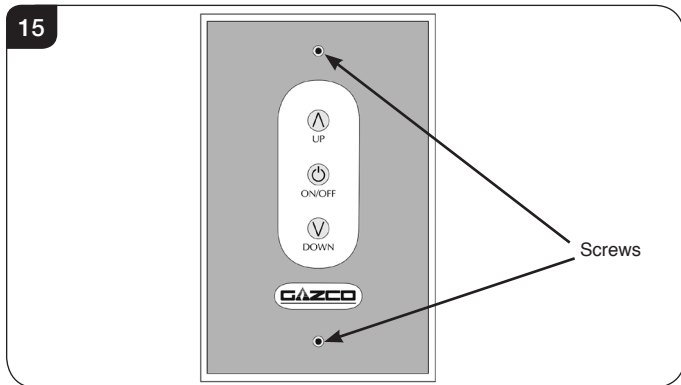

PLEASE ENSURE NO WIRES ARE TRAPPED BEFORE REPLACING THE WALL PLATE. THE TOUCH PAD LEAD IS EASILY DAMAGED.

5. Masonry Chimney Installation

Note: This appliance is supplied as an edge installation but it is possible to fit a frame at a later stage without any remedial building work needed. However the appliance must originally be installed a minimum of 150mm above floor level to allow for this.

This appliance is designed so that non-combustible board can be taken right up to the edge of the flange.

There are two methods of installation into a masonry chimney.

METHOD 1

5.1 Fix the self adhesive foam seal around the back of the fixing flange of the appliance.

5.2 Install the appliance into the aperture. Ensure that the gas pipe passes through the silicon panel at the back of the appliance and the wall panel cable passes through the side grommet.

Note: It may be necessary to feed the wall plate cable through the silicon panel during installation.

5.3 Secure the appliance through the 6 fixing holes using the screws provided, see Diagram 16.

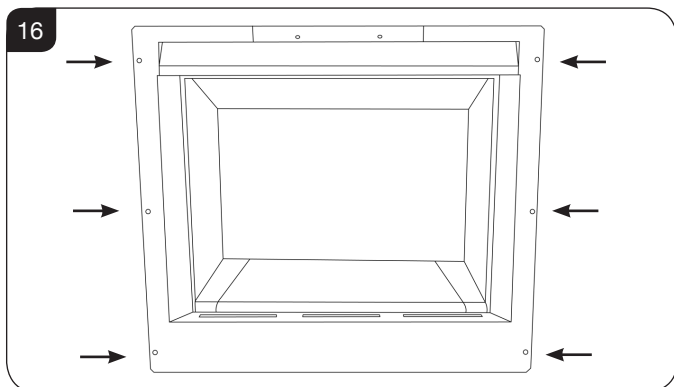

5.4 Build the chimney breast up to coincide with the edge, allowing for the front to be skimmed level.

5.5 Fit non-combustible board to the chimney breast around the appliance, using the distance to combustibles detailed in Diagram 17.

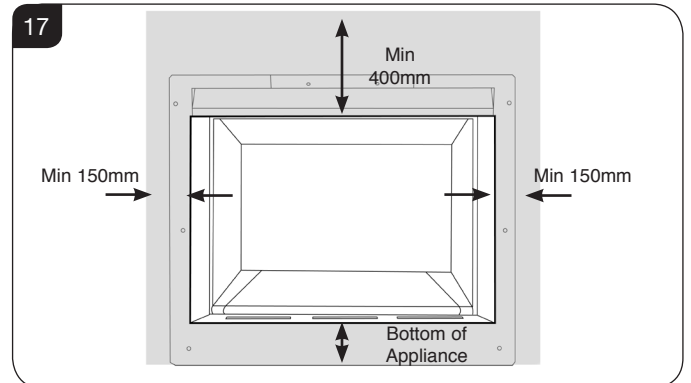

5.6 Fit plasterboard to the remaining of the chimney breast front.

5.7 Apply a heat resistant plaster around the appliance using the distance to combustibles detailed in Diagram 17.

5.8 Apply a plaster finish to remaining chimney breast front.

METHOD 2

5.9 Remove the plaster from the chimney breast front around the aperture, back to the brickwork, using the distance to combustibles detailed in Diagram 17.

5.10 Fix the self adhesive foam seal around the back of the fixing flange of the appliance.

5.11 Install the appliance into the aperture. Ensure that the gas pipe passes through the silicon panel at the back of the appliance and the wall panel cable passes through the side grommet.

Note: It may be necessary to feed the wall plate cable through the silicon panel during installation.

5.12 Secure the appliance to the brickwork through the 6 fixing holes using the screws provided, see Diagram 16.

Note: The existing plaster should line up with the edge of the appliance, see Diagram 18.

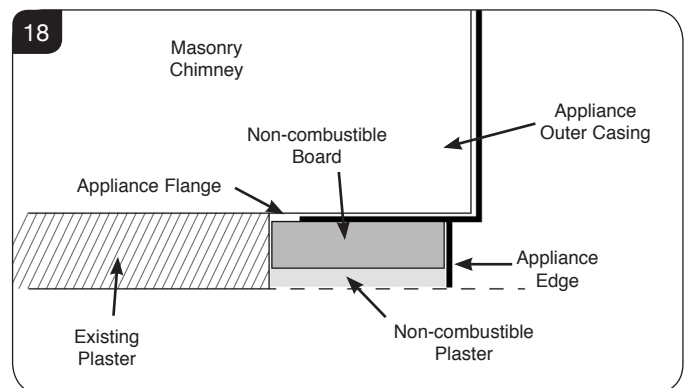

5.13 Fit non-combustible board to the chimney breast around the appliance to join the existing plaster, see Diagram 18, see distance to combustibles in Diagram 17.

Installation Instructions

6.12 Secure the appliance through the 6 fixing holes, using the screws provided, see Diagram 23.

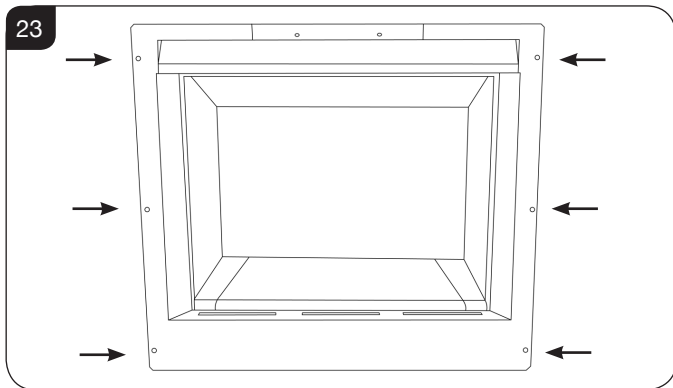

6.13 Fit non-combustible board to the board around the appliance, see Diagram 24. Ensure distances to combustibles are observed, see Diagram 21.

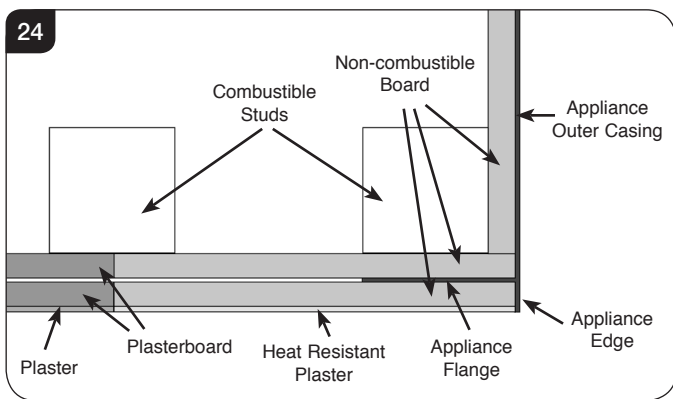

NOTE: If metal studwork is used, there is no need to fit non-combustible board to the face of the construction, see Diagram 25.

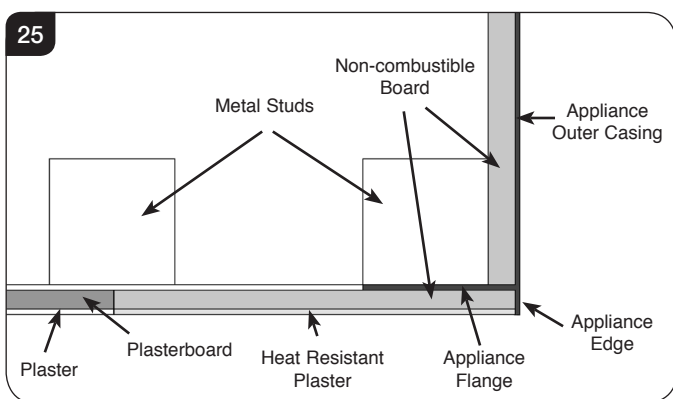

6.14 Apply plasterboard to the remainder of the first layer of plasterboard.

6.15 Apply a heat resistant plaster around the appliance, see Diagram 24. Ensure distances to combustibles are observed, see Diagram 21.

6.16 Apply a plaster finish to the remaining plasterboard.

To finish this installation:

6.17 Connect the wall box and batteries following instruction in Section 4.

6.18 Connect the flue system.

6.19 Connect the gas services using the opening in the side of the chimney breast for access.

After commissioning:

6.20 Finish the sides of the chimney breast, see Diagram 26.

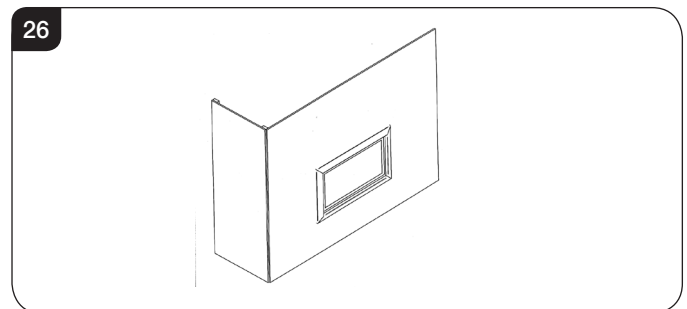

7. Gas Soundness Pressure Check

7.1 Connect a suitable pressure gauge to the test point located on the inlet fitting and turn the gas supply on. Light the appliance and check all gas joints for possible leaks. Turn the appliance to maximum and check that the supply pressure is as stated on the databadge. Turn the gas off and replace the test point screw, turn the gas on and check the test point for leaks.

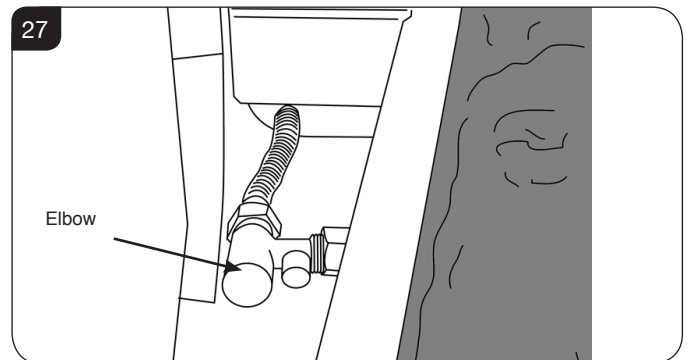

Check the function of the handset, if there is no communication between the remote control and the appliance, see Commissioning Section 2.

Installation Instructions

Advice on handling and disposal of fire ceramics



The fuel effect and side panels in this appliance are made from Refractory Ceramic Fibre (RCF), a material which is commonly used for this application.

Protective clothing is not required when handling these articles, but we recommend you follow normal hygiene rules of not smoking, eating or drinking in the work area and always wash your hands before eating or drinking.

To ensure that the release of RCF fibres are kept to a minimum, during installation and servicing a HEPA filtered vacuum is recommended to remove any dust accumulated in and around the appliance before and after working on it. When servicing the appliance it is recommended that the replaced items are not broken up, but are sealed within heavy duty polythene bags and labelled as RCF waste.

RCF waste is classed as stable, non-reactive hazardous waste and may be disposed of at a licensed landfill site.

Excessive exposure to these materials may cause temporary irritation to eyes, skin and respiratory tract; wash hands thoroughly after handling the material.

8. Removal & Fitting the Liners

- 8.1 The baffle must be removed before the liners can be fitted.
- 8.2 To do this undo the 3 screws securing it to the roof of the firebox, see Diagram 28.

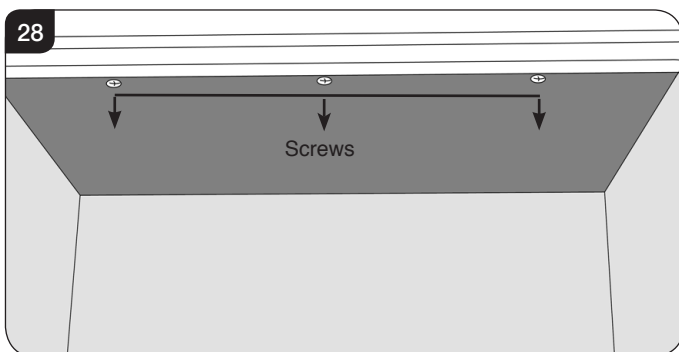

- 8.3 The baffle can now be removed by lowering the front edge and pulling forward through the front of the appliance. **TAKE CARE NOT TO DAMAGE THE SIDE PANELS**
- 8.4 Replace left hand metal side cover, see Diagram 29. Ensure that the front tab engages with the slot in the front flange of the appliance.

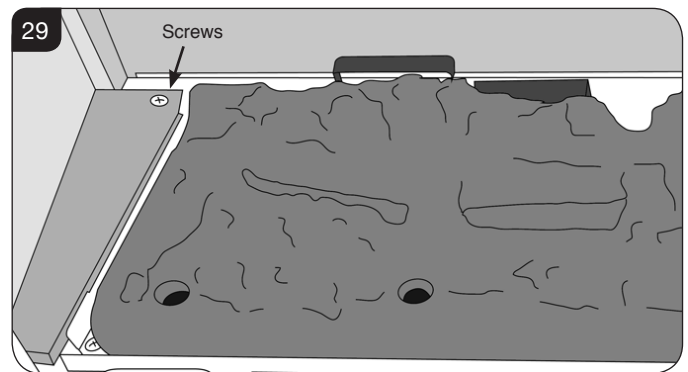

- 8.5 Fit the back liner by carefully lifting over the bottom bracket and twisting slightly to allow it to be inserted through the front of the appliance, see Diagram 30.

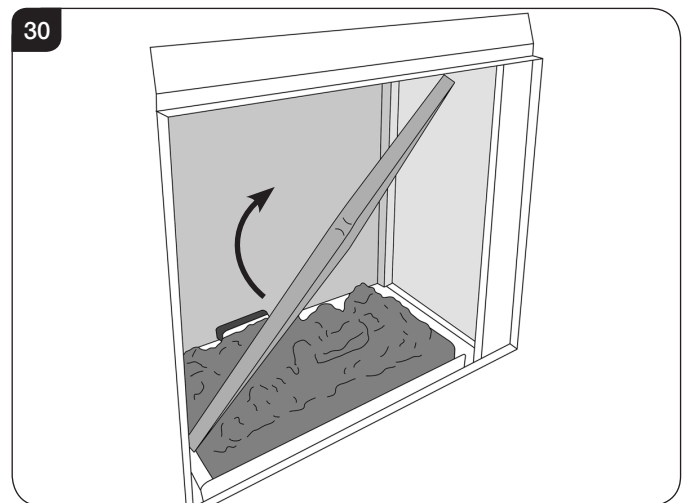

- 8.6 To fit the Right Hand liner insert through the front of the appliance tilting the top inwards towards the centre of the firebox before lowering into position, see Diagram 31.

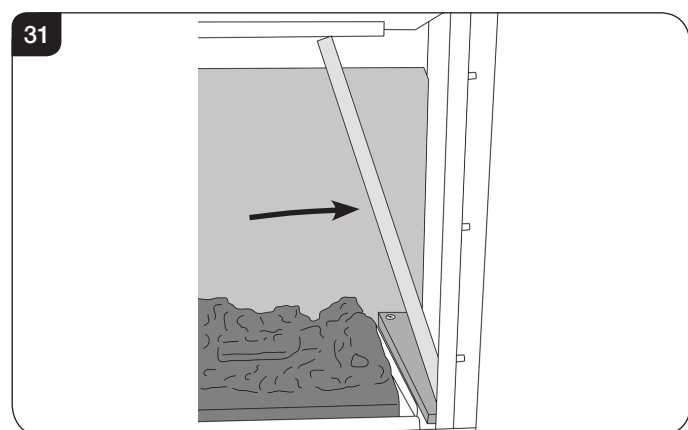

- 8.7 To fit the Left Hand liner insert through the front of the appliance tilting the top inwards towards the centre of the firebox before lowering into position, see Diagram 31.

The 2 side liners also support the rear panel.

- 8.8 Fit the 2 lower ceramic cover panels, see Diagram 32.

Installation Instructions

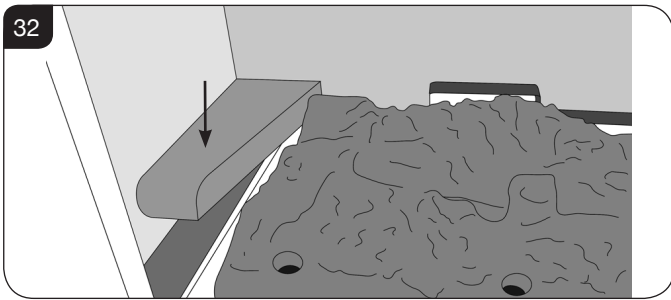

8.9 Replace the baffle ensuring that the 3 tabs fit into the slots at the back of the appliance, see Diagram 33. Take care not to damage the liners.

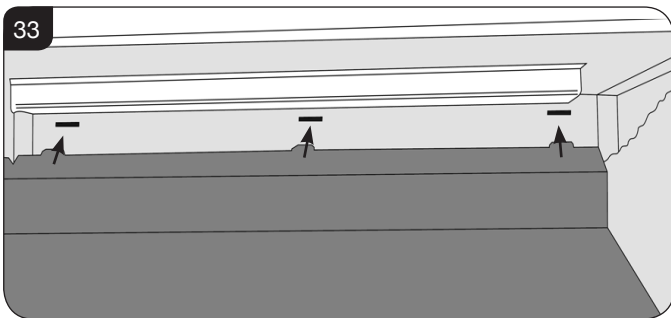

8.10 Replace the 3 screws to secure it to the roof of the firebox, See Diagram 34.

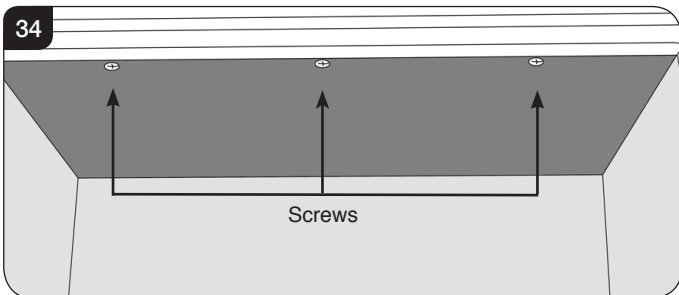

9. Arrangement of Fuel Bed Components

LOGS MUST BE POSITIONED ACCORDING TO THE FOLLOWING INSTRUCTIONS TO GIVE THE CORRECT FLAME EFFECT.

- 9.1 Ensure the burner tray is clean and free from any debris.
- 9.2 The logs for the fuel bed are clearly individually labelled, see Diagram 35.

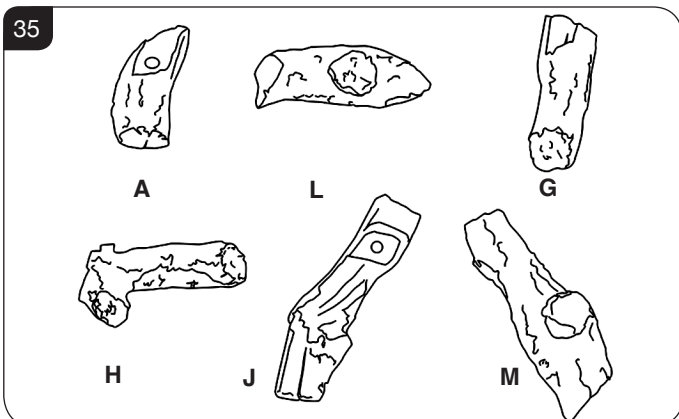

9.3 Place log A on the left hand front of the burner. The log will fit over the raised stud and into the groove in the burner tray, see Diagram 36.

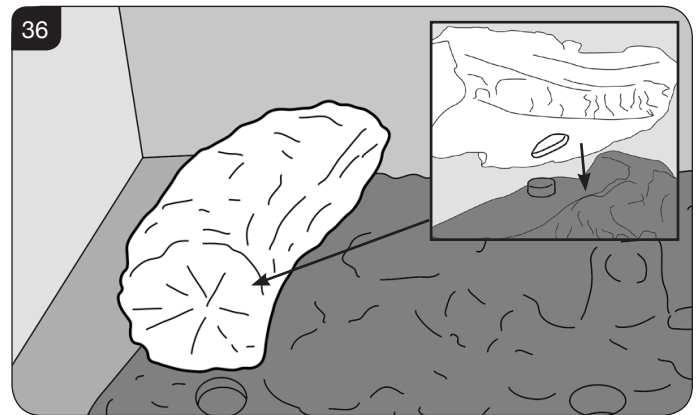

9.4 Place Log L behind the Log A on the flat plain and locate the rear of the log on the metal bracket. The log should rest between the lip of the bracket and the rear liner, see Diagram 37.

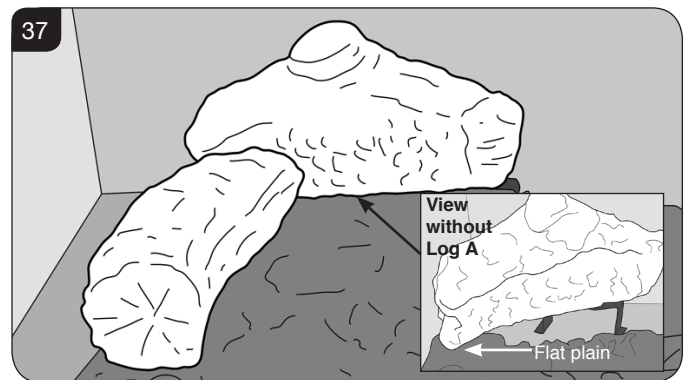

9.5 Place Log G on top of Log A. There is a hole on the underside of Log G which fits over the raised stud on Log A to secure in place. The end of the log sits on the raised section of the burner tray, see Diagram 38.

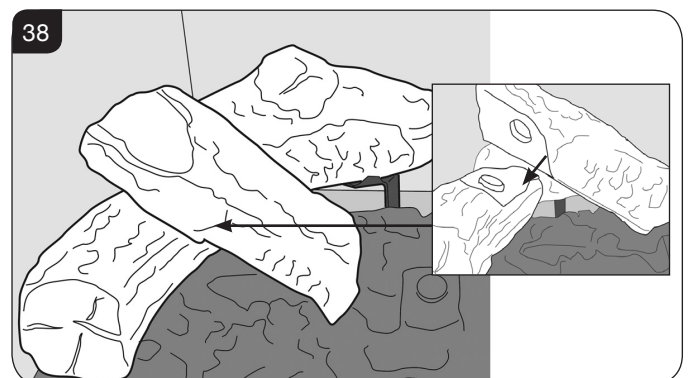

9.6 Place Log H on the centre of the burner tray. There is a raised stud in the fuel bed which securely locates the log in place. The right hand side rests on the raised section at the end of the air cutout, see Diagram 39.

Installation Instructions

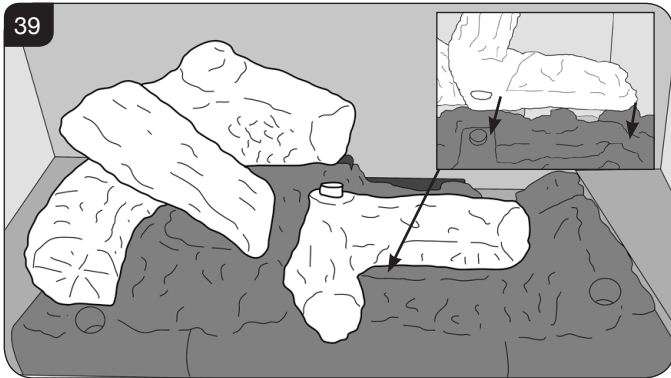

9.7 Rest Log J on the raised stud on Log H. The rear of the effect should rest on the metal bracket at the back of the burner tray, see Diagram 40.

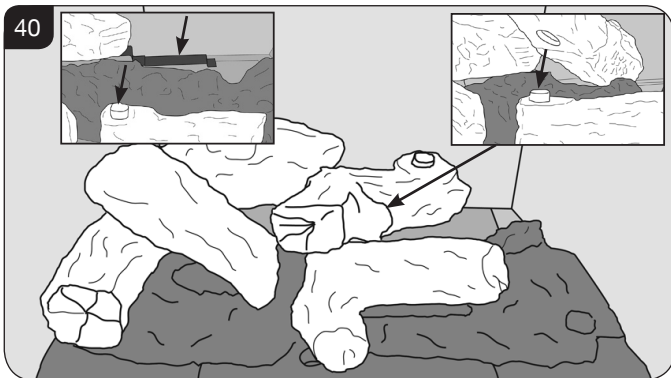

9.8 Sit the first hole in the bottom of the left hand side of Log M on the stud of Log H and secure by fitting the middle hole on the right hand side over the stud in the fuel bed by the burner port, see Diagram 41.

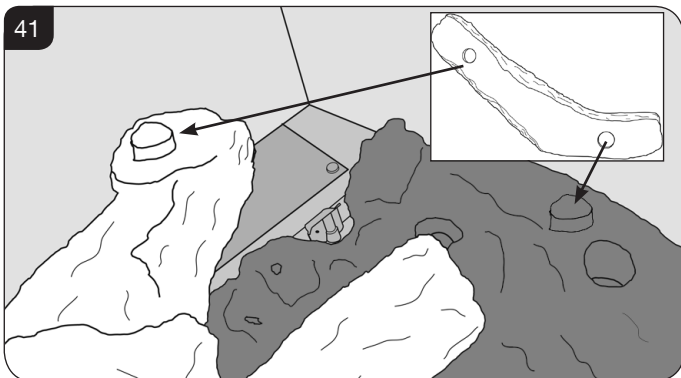

9.9 Log M should rest on the flat plain behind the stud for the Log arrangement to be complete, see Diagram 42.

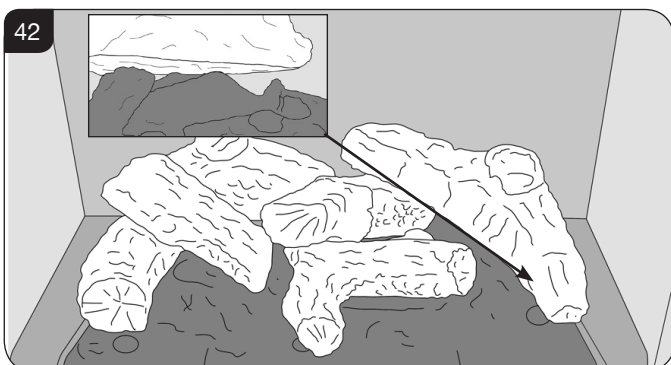

9.10 Place the small pieces of bark down either side, see Diagram 43.

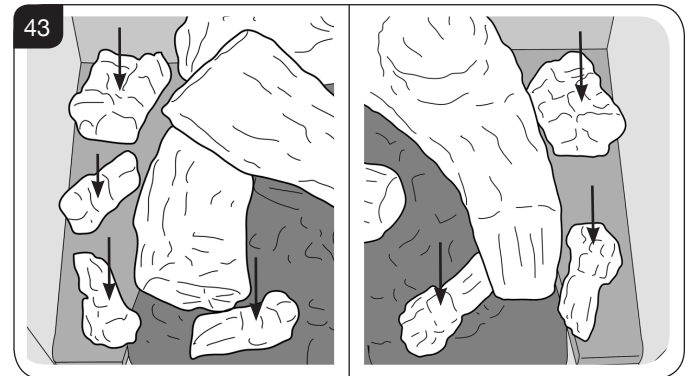

9.11 Lay emberglow over the small ports in the base of the burner tray. This will create a glowing effect when the appliance is lit, see Diagram 44.

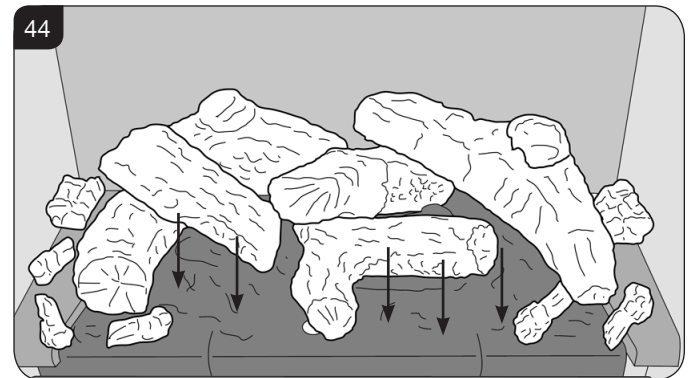

10. Completion of Assembly

Ensure that the fibreglass seal on the back of the glass frame is intact.

10.1 To replace the glass frame, position so the hooks on the back of the frame fit over the side pins, see Diagram 45.

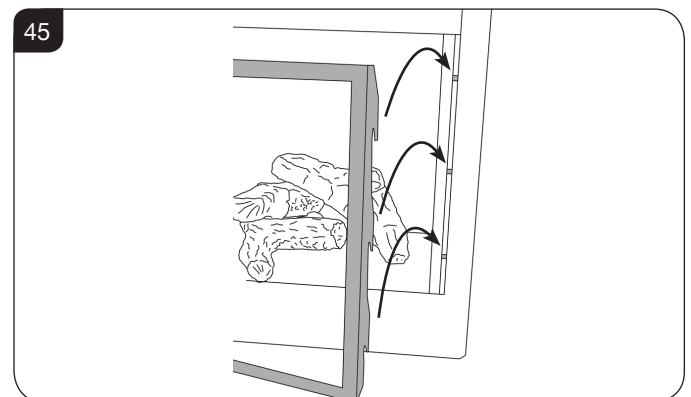

10.2 Push the handle down.

10.3 Replace the screws. As the screws are tightened the glass frame is pulled down against the hooks and forms a seal. **Replace ALL of the securing screws ensuring that a screw is present in all fixing slots.**

Installation Instructions



UNDER NO CIRCUMSTANCES SHOULD THE APPLIANCE BE USED IF ANY OF THE GLASS FRAME RETAINING SCREWS ARE LOOSE OR MISSING.

- 10.4 Replace the lower trim, ensuring that the angled metal shield is sloping towards the door frame.
- 10.5 Replace the 2 magnetic side trims.

NEVER OPERATE THE APPLIANCE WHEN THE GLASS PANEL IS REMOVED OR BROKEN.

- 10.6 Replace the decorative front by referring to the separate leaflet supplied with the front.

NOTE: ENSURE THAT THE LOGS ARE POSITIONED AS ABOVE. ONLY USE THE CORRECT AMOUNT OF LOGS AS SPECIFIED IN THE DIAGRAMS.

14. Operating the Appliance

- 14.1 The appliance has 4 flame settings:
 1. High.
 2. Medium.
 3. Low.
 4. Standby (Pilot only).
- 14.2 Both touch pad and handset allow you to manually switch between flame settings.
- 14.3 The Thermostatic handset also allows to set the appliance to automatically regulate the room temperature.

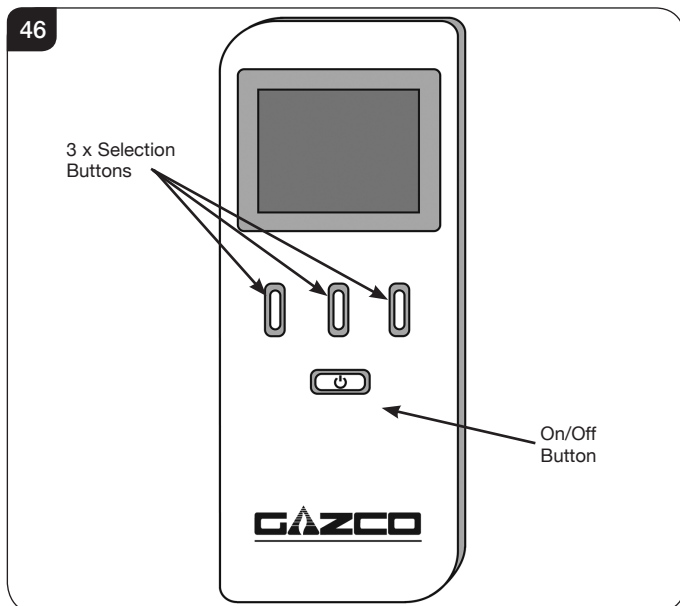

Before using the remote control:

- 14.4 If there is no display on the LCD screen press any key.

- 14.5 When first powered, the handset displays the OFF screen. The handset may be locked as indicated by the padlock symbol (🔒), see Diagram 66.

NOTE: To select a function from the options displayed at the bottom of the screen press the button directly below the desired function.

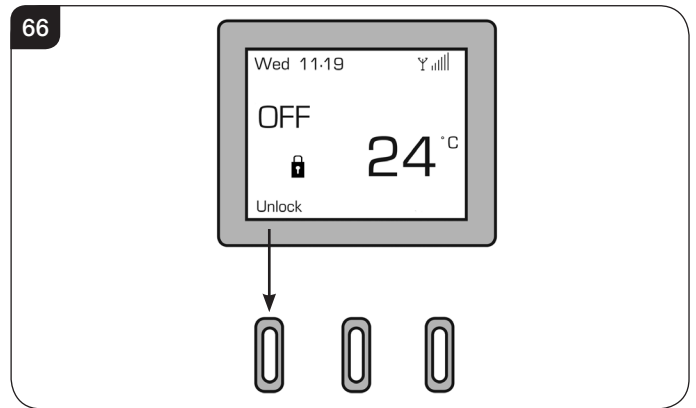

- 14.6 To unlock the handset select Unlock followed by OK - the symbol will change to an open padlock (🔓).
- 14.7 There are 3 different modes available for controlling and operating the appliance for full operating details see Section 2, User Instructions.

When a command from the handset is received a beep will sound and the LED on the handset will briefly illuminate.

NOTE: The LED flashes every 4 seconds to show that it is communicating with the appliance. After each command has been accepted the LED will cease flashing until the command has been carried out. Wait until the LED resumes flashing before giving another command.

Manual Mode

Switching the Appliance ON:

- 14.8 To light the appliance press the On/Off (🔌) button, this will bring up the LCD screen. Select the 'On' option on the left of the screen immediately followed directly by the OK button, a single beep will sound.

After the start up cycle has completed the appliance will light on the high flame setting (this can take up to 20 seconds).

Select the 'Manual' option on the screen to control the appliance.

Decreasing the Flame Height:

- 14.9 From the high flame setting press DOWN (↓) once to lower the flame to the medium setting.
- 14.10 From the medium flame setting press DOWN (↓) once to lower the flame to the low setting.
- 14.11 From the low flame setting press DOWN (↓) once to put the appliance in Standby mode (Pilot only).

Installation Instructions

Increasing the Flame Height:

- 14.12 To light the appliance when it is in Standby mode press UP (↑) once. The appliance will light on the **Low** flame setting.
- 14.13 From the low setting press UP (↑) once to increase the flame setting to medium.
- 14.14 From the medium setting press UP (↑) once to increase the flame setting to high.



WARNING: IF THE APPLIANCE FAILS TO LIGHT OR BECOMES EXTINGUISHED IN USE, WAIT 3 MINUTES BEFORE ATTEMPTING TO RELIGHT.



IMPORTANT: YELLOW FLAMES TYPICALLY APPEAR WHEN THE APPLIANCE HAS REACHED NORMAL OPERATING TEMPERATURE. THIS CAN TAKE UP TO 30 MINUTES.

Switching the Appliance OFF:

- 14.15 To switch the appliance OFF press the On/Off (⏻) button once, see Diagram 65.

FOR FULL OPERATING INSTRUCTIONS AND TROUBLESHOOTING SEE USER SECTION.

15. Touch Pad Control

59



The touch pad control is located on the front of the wall switch and allows manual operation of the appliance, see Diagram 67.

With the touch pad it is possible to turn the appliance ON, OFF and control the flame setting.

NOTE: When using the touch pad buttons a beep will be emitted from the appliance to indicate an accepted command.

Lighting the appliance

- 15.1 Press the On/Off button once.

If the pilot fails to light, press the ON/OFF button to switch OFF. Wait for at least 30 seconds before attempting to relight.
- 15.2 After the start up cycle has completed the appliance will light on the **high flame setting** (this can take up to 20 seconds).

If the appliance is in Standby mode, pressing the UP (↑) button will cause the main burner to ignite on the **Low** flame setting.
- 15.3 To increase the flame height press the UP (↑) button.
- 15.4 To decrease the flame height press the DOWN (↓) button.
- 15.5 When on the lowest flame setting pressing the Down (↓) button will switch the appliance to Standby mode (pilot only).



WARNING: IF THE APPLIANCE FAILS TO LIGHT OR BECOMES EXTINGUISHED IN USE, WAIT 3 MINUTES BEFORE ATTEMPTING TO RELIGHT.



IMPORTANT: YELLOW FLAMES TYPICALLY APPEAR WHEN THE APPLIANCE HAS REACHED NORMAL OPERATING TEMPERATURE. THIS CAN TAKE UP TO 30 MINUTES.

To Switch the Appliance OFF:

- 15.6 To turn the appliance **OFF** press the On/Off button once.

Touch Pad Control Not Working

If the appliance is not operating with the touch pad control:

- 15.7 Replace the batteries in the wall switch unit, see Section 6, User Instructions.
- 15.8 If the appliance still fails to operate consult your installer or Gazco retailer.

Commissioning

1. Commissioning

- 1.1 Check the flame picture, log/ fuel effect layout.
- 1.2 Check the gas pressure.
- 1.3 Close all door sand windows in the room.
- 1.4 Ignite the Riva2 500 and operate on maximum for 5 minutes.
- 1.5 Position a lighted smoke match just inside the draught diverter opening (under the canopy) and check all smoke is drawn in along the opening, see Diagram 1.

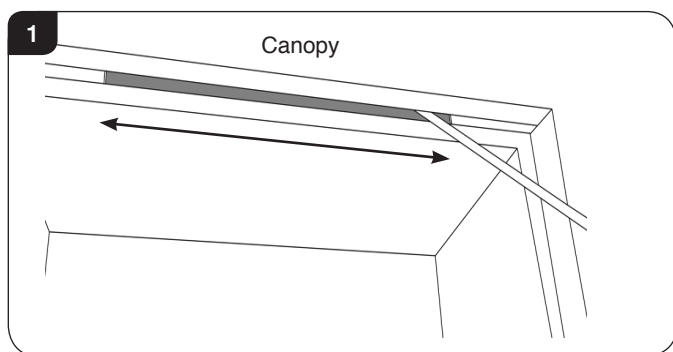

If there is any doubt:

- 1.6 Run the appliance for a further 10 minutes and repeat the test.
- 1.7 Complete the Commissioning Checklist at the front of this manual covering:
 - Flue checks
 - Gas checks
 - Log/fuel effect layout - flame picture

For working pressure test, refer to Installation Instructions Section 7.
- 1.8 Upon completion of the commissioning and testing of the installation and correct operation of the appliance, the installer must instruct the user how to operate the appliance.
- 1.9 Guide the user through the User Instructions paying particular attention to:
 - a) Regular servicing (Section 13 of the User Instructions).
 - b) Ventilation (Section 14 of the User Instructions) - point out the ventilation positions where applicable.
 - c) Hot surfaces (Section 16 of the User Instructions).
 - d) How the appliance works with the touch pad control (Section 5 of the User Instructions).
 - e) How the appliance works with the remote control handset and the modes of operation (Section 2 of the User Instructions).

f) How to change settings in the auto mode and program modes of operation.

g) What to do if the appliance fails to operate (Section 17 of the User Instructions).

If there are any extractor fans in the room or adjacent rooms, the test must be repeated with the fans running on maximum.

IF SPILLAGE PERSISTS, DISCONNECT THE APPLIANCE AND SEEK EXPERT ADVICE.

For future reference, record the installation details on the Commissioning Sheet on page 3.

2. Pairing the appliance

i To access the control panel in order to pair the appliance it will be necessary to remove the Main Control Assembly, see Servicing Section 4.

If there is no communication between the remote control and the appliance after replacing the control box or the handset, it will be necessary to pair the two together.

Before starting the pairing process ensure the handset is programmed to Channel 'C' see Section 3.

- 2.2 Ensure batteries are fitted and working in the handset.
- 2.3 Check all leads and cables are connected correctly.
- 2.4 Ensure the handset is unlocked. To unlock the handset select Unlock followed by OK - the symbol will change to (☑).
- 2.5 Press the ON/OFF button (⏻) on the handset and keep it depressed until the screen changes to the configuration menu. This may take up to 30 seconds and the screen may go blank before changing to the configuration screen.
- 2.6 When the configuration menu screen appears change the Pairing option to ON using the Change button.
- 2.7 Within 20 seconds press the yellow button on the control unit repeatedly until a single beep is heard confirming the pairing operation has been successful, see Diagram 1. This may be easier using a pencil, ball point pen or similar.

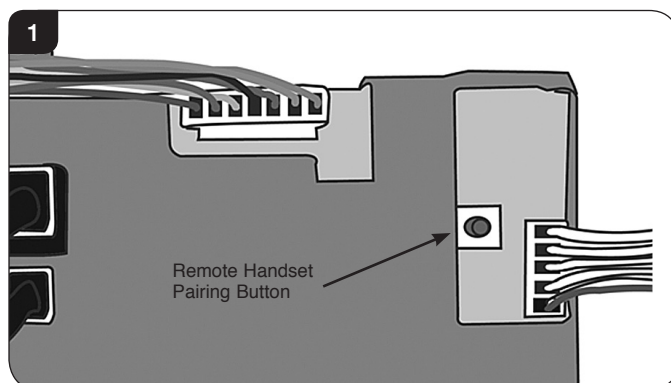

- 2.8 The remote handset will display a signal level in the top right hand corner. This may take up to 4 minutes.
- 2.9 Press the back button on the handset to return to the configuration menu and then again to return to the main menu.

3. Changing channel



WHEN ATTEMPTING A NEW PAIRING PROCEDURE THE HANDSET SHOULD BE SET TO CHANNEL 'C'. IF THE APPLIANCE IS ALREADY SET TO CHANNEL 'C' BUT NO COMMUNICATION SIGNAL STRENGTH IS SHOWN ON THE HANDSET, IT WILL BE NECESSARY TO CHANGE THE COMMUNICATION CHANNEL USING THE FOLLOWING PROCEDURE.

- 3.1 Ensure the handset is unlocked. To unlock the handset select Unlock followed by OK - the symbol will change to (☑).
- 3.2 Press the ON/OFF button (⏻) on the handset and keep it depressed until the screen changes to the configuration menu. This may take up to 30 seconds and the screen may go blank before changing to the configuration screen.
- 3.3 Press the button below the down arrow (↓) to scroll through the menu until 'Channel' is displayed.
- 3.4 The channel is normally pre-set to C. Press the button below 'Select' and then use the down arrow (↓) to set the handset to channel A or B.
- 3.5 Disconnect the batteries from the control box and reconnect after 10 seconds.
- 3.6 The remote handset will display a signal level in the top right hand corner. This may take up to 4 minutes, check the strength of the signal in the top right hand corner of the LCD display (Y▬▬▬).

Servicing Instructions

Servicing/Fault Finding Charts

1. Servicing Requirements

IMPORTANT – The glass panel on this appliance should be checked for any signs of damage on the front face of the glass panel (scratches, scores, cracks or other surface defects). If damage is observed, the glass panel must be replaced and the appliance must not be used until a replacement is installed. Under no circumstances should the appliance be used if any damage is observed. Please isolate the appliance until a replacement glass panel has been obtained and installed. Replacement glass panels can be purchased from Gazco via the retailer from which the appliance was purchased or any other Gazco distributor.

This appliance must be serviced at least once a year by a competent person.

All tests must be carried out in accordance with the current Gas Safe recommendations.

1.1 Before Testing:

- Conduct a gas soundness test for the property ensuring there are no leaks before servicing.
- Check the operation of the appliance before testing.

1.2 Special checks:

- Clean the burner using a vacuum cleaner with a soft brush attachment. Ensure all debris is removed from the burner ports.
- Clean away lint or fluff from the pilot.
- Clean away lint or fluff from under the burner.
- Check the spark gap on the pilot is correct.
- Ensure that the glass frame is secured correctly and that all retaining screws are in place.

1.3 Correct any faults found during the initial test.

1.4 Re-commission the appliance in accordance with Commissioning Procedures of these instructions.

1.5 Advise the customer of any remedial work undertaken.

REPLACE BATTERIES BEFORE ATTEMPTING TO RECTIFY ANY FAULTS.

IGNITION FUNCTIONAL CHECK 1

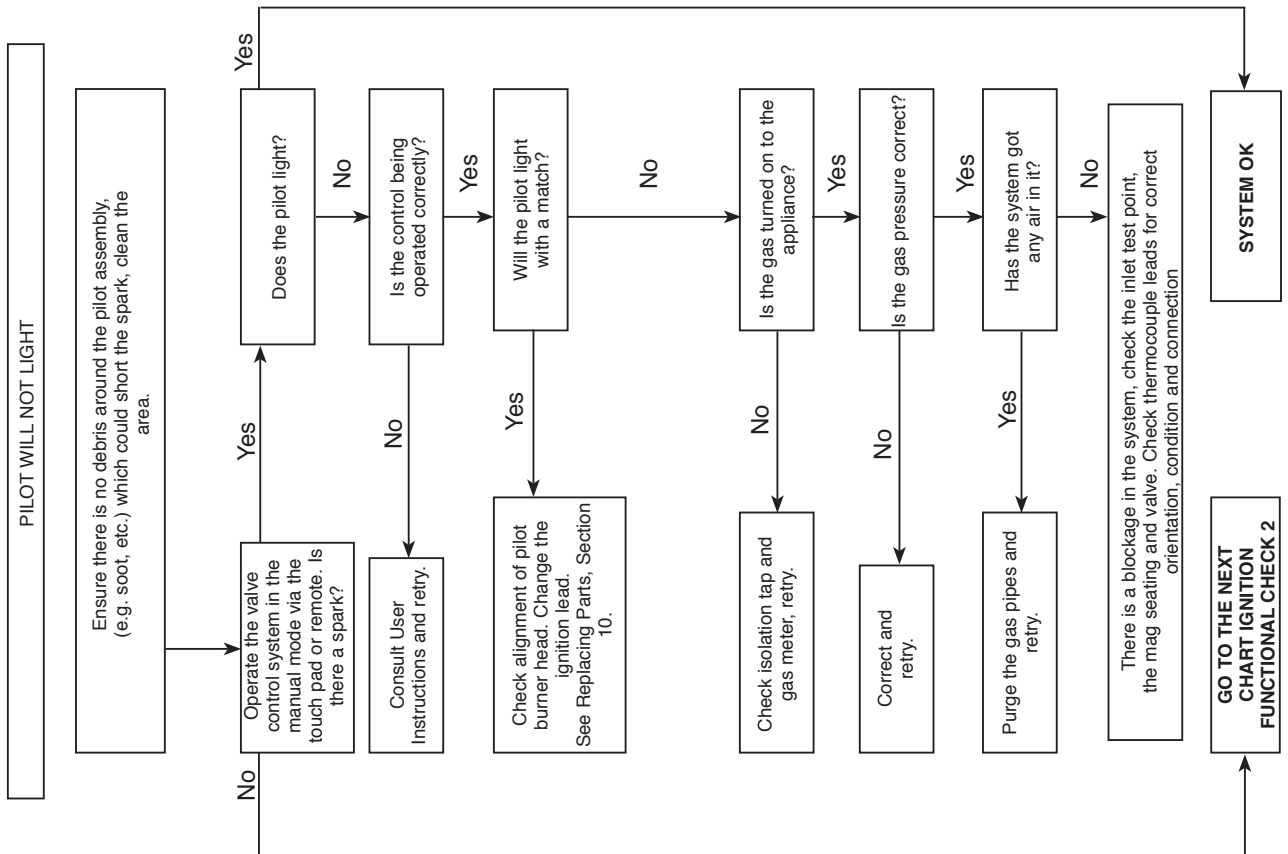

Servicing Instructions

Fault Finding Charts

FLAME FAILURE FUNCTIONAL CHECK 3

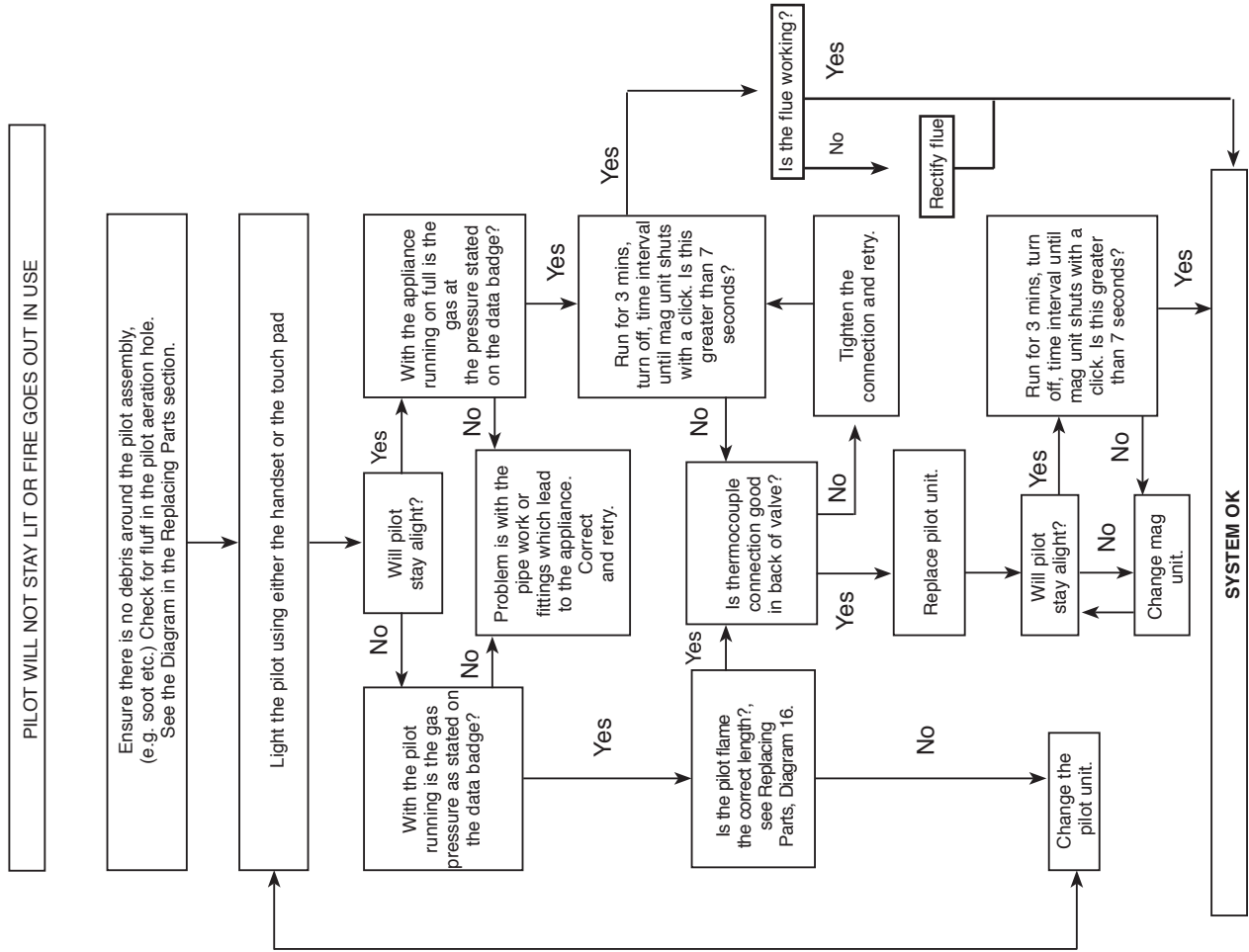

IGNITION FUNCTIONAL CHECK 2

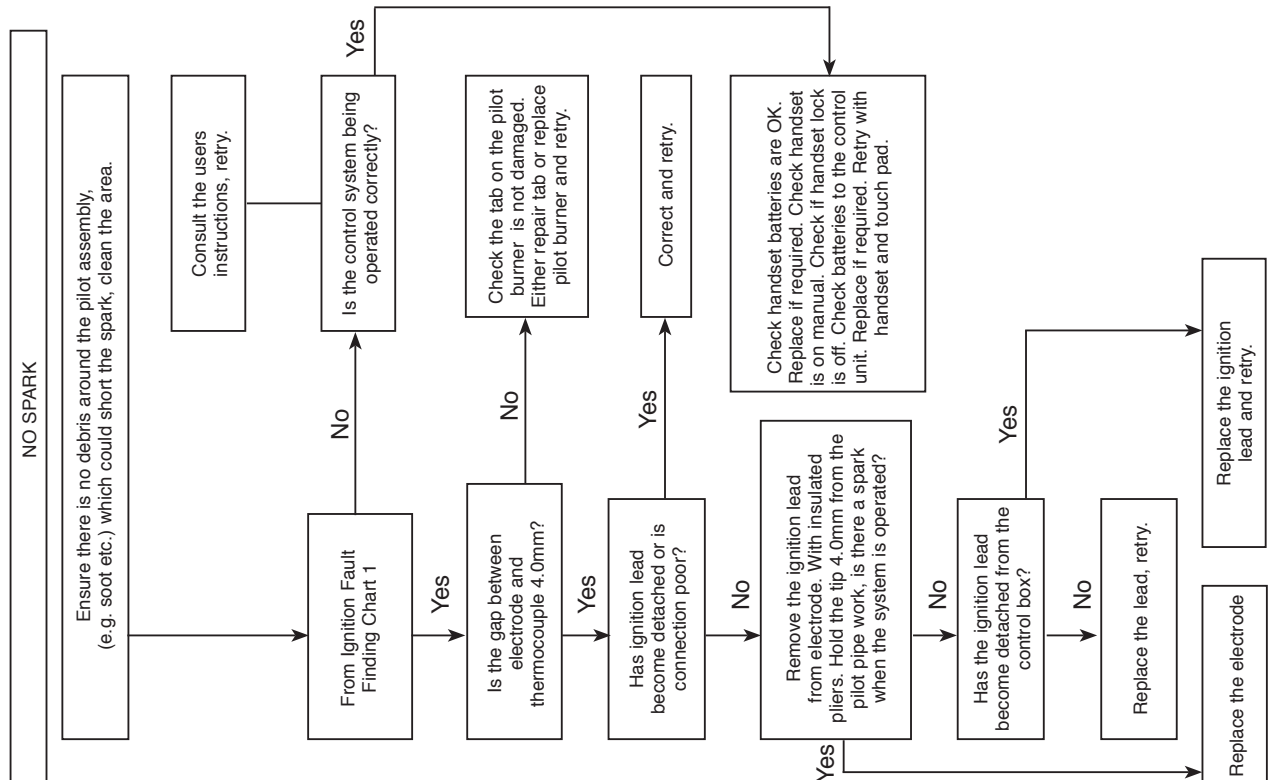

Servicing Instructions

Fault Finding Charts

ELECTRONIC CONTROL VALVE FAULT ANALYSIS

Problem	Cause	Error Message	LCD Display	Solution	
Does not ignite	No batteries or flat batteries in battery box	10 beeps	BATTERY ERROR	Place new batteries in battery box	
	ROM error	2 cycles of 3 beeps	ROM ERROR	Change control unit	
	Support test error	2 cycles of 5 beeps	SUPPORT ERROR	Connect earth cable from control box to valve	
	Bad reception of remote handset signal				Change batteries in the remote handset
					Check the reception of signal from a shorter distance
					Try pairing again
				Try changing the channel in the configuration menu	
	No response to touch control buttons	If LED is continuously on, the cable is connected the wrong way round		Ensure the touch control cable is correctly connected (see installation manual)	
Cable loose or broken or connected wrong way round			Change touch control		
Supply cable to valve disconnected or broken	2 cycles of 5 beeps	SUPPORT ERROR	Reconnect or replace valve cable		
Ignition cable disconnected or broken			Connect ignition cable		
Sparks but no pilot ignition	Gas valve supply off or no gas			Check gas installation. Open gas valve	
	Valve cable disconnected or broken			Connect valve cable correctly	
	Interrupter cable disconnected or broken			Connect correctly or replace pilot cable	
Pilot ignites but does not stay on	Pilot is not warmed up			Check pilot flame and verify that it heats the pilot	
	Interrupter cable badly connected			Change polarity of pilot cable	
	Interrupter cable disconnected or broken			Connect pilot cable	
Ignites from remote handset but not from touch pad	Touch control cable disconnected or broken			Connect or replace touch control cable	
	Defective touch control buttons			Change touch control	
Ignites from touch pad but not from remote	Bad communication with handset			Check batteries in handset	
				Check reception of signal from a shorter distance	
				Try pairing again	
				Try changing the channel in the configuration menu	
Switches off after 6 seconds	Short circuit in touch control	5 beeps	BUTTON ERROR	Change touch control wiring	
Low batteries on remote			Low battery	Change the batteries in the remote	
Appliance switches off		2 cycles of 3 beeps	CONFIG ERROR	Change control unit	
		2 cycles of 3 beeps	EEPROM ERROR	Try pairing again	
				Change control unit	
	Loss of communication between appliance and remote for 18min	20 beeps		The remote is too far from the appliance	
				Replace batteries in handset	
High temperature on control unit	1 long beep	TEMP ERROR		If this occurs more than once call the technical service	
Ambient temperature higher than configured			Over Temperature	Check the correct configuration of safety temperature	

Servicing Instructions - Replacing Parts

1. General

- 1.1 All principal components can be replaced without removing the appliance from its installation, although it is essential that the gas supply to the appliance is turned off at the isolation device before proceeding further.
- 1.2 It will be necessary to remove the complete burner module before any of the components can be serviced.

2. Removing the Glass Frame

- 2.1 Remove the glass frame by removing the 2 side trims, see Diagram 1. These are held on by magnets.

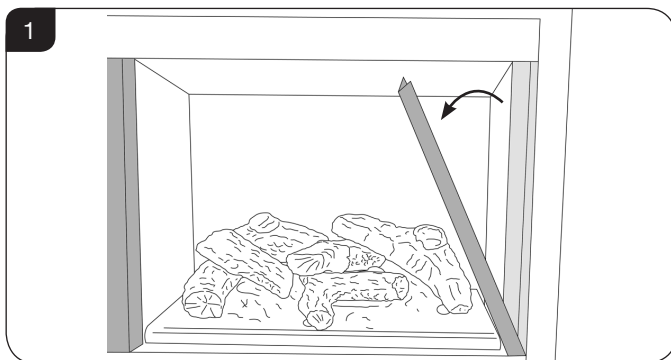

- 2.2 Lift out the bottom slotted trim, see Diagram 2. Note the orientation of the metal shield for reassembly.

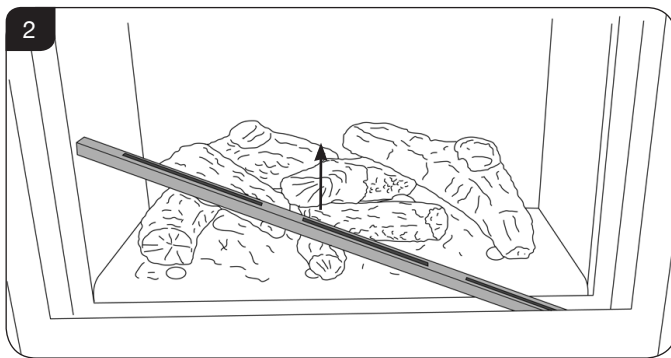

- 2.3 Remove the 2 screws at the base of the door, see Diagram 3.

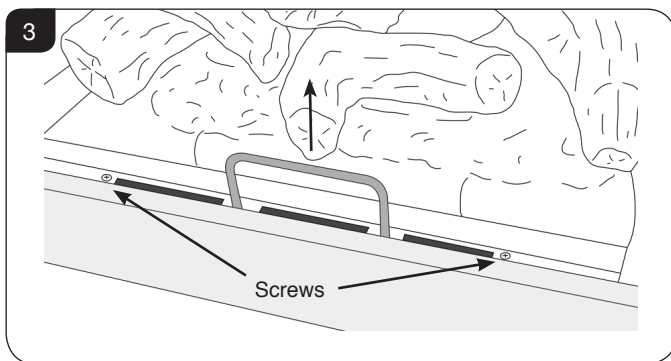

- 2.4 Pull up the handle at the front, see Diagram 3.

- 2.5 Whilst supporting the top, lift the door using the handle, up and over the lower edge, see Diagram 4.

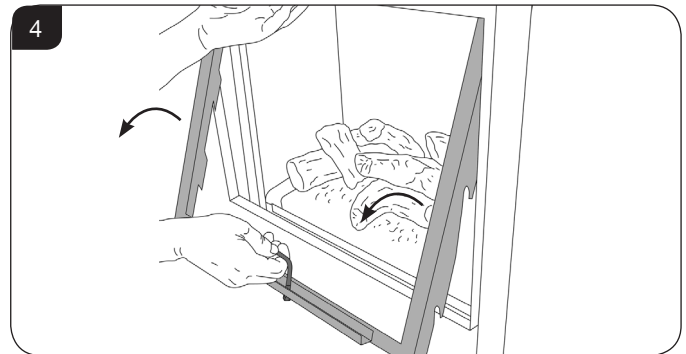

- 2.6 Remove the logs, and place them on a dry, clean surface.

When refitting the glass frame ensure that the fibreglass seal on the back of the frame is intact.

- 2.7 To replace the glass frame, position so the hooks on the back of the frame fit over the side pins, see Diagram 4.
- 2.8 Push the handle down.
- 2.9 Replace the screws. As the screws are tightened the glass frame is pulled down against the hooks and forms a seal. **Replace ALL of the securing screws ensuring that a screw is present in all fixing slots.**



UNDER NO CIRCUMSTANCES SHOULD THE APPLIANCE BE USED IF ANY OF THE GLASS FRAME RETAINING SCREWS ARE LOOSE OR MISSING.

- 2.10 Replace the lower trim, ensuring that the angled metal shield is sloping towards the door frame.
- 2.11 Replace the 2 magnetic side trims.

NEVER OPERATE THE APPLIANCE WHEN THE GLASS PANEL IS REMOVED OR BROKEN.

- 2.12 The glass front must be refitted to the appliance following cleaning or servicing.

3. Baffle & Vermiculite Liners

- 3.1 To access the burner tray and interior workings of the appliance it is necessary to remove the baffle and the liners.
- 3.2 Remove the 2 lower ceramic cover panels, see Diagram 5.

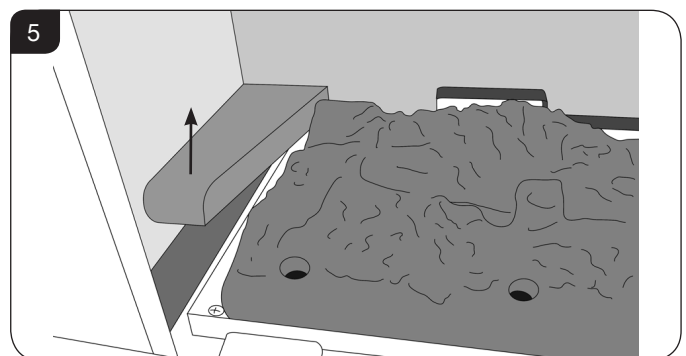

Servicing Instructions - Replacing Parts

BAFFLE

The baffle must be removed before the liners can be taken out of the appliance.

- 3.3 To do this undo the 3 screws securing it to the roof of the firebox, see Diagram 6.

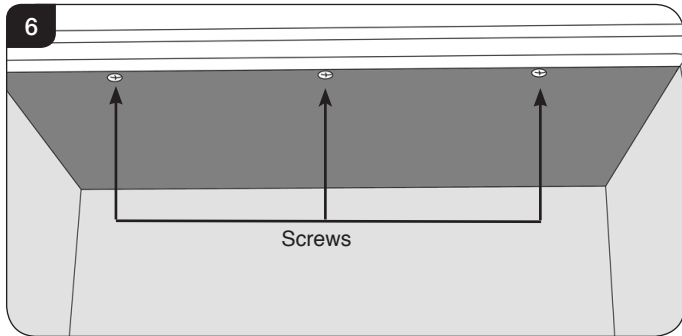

- 3.4 The baffle can now be removed by lowering the front edge and pulling forward through the front of the appliance. **TAKE CARE NOT TO DAMAGE THE SIDE PANELS**

- 3.5 When replacing the baffle ensure that the 3 tabs fit into the slots at the back of the appliance, see Diagram 7.

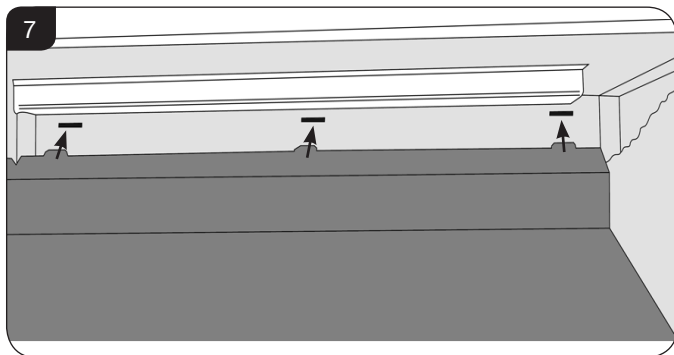

VERMICULITE LINERS

Once the baffle has been placed carefully to one side the liners can then be taken out in the following order.

- 3.6 To remove the Right Hand liner first tilt inwards towards the centre of the firebox before lifting up and pulling out through the front of the firebox, see Diagram 8.

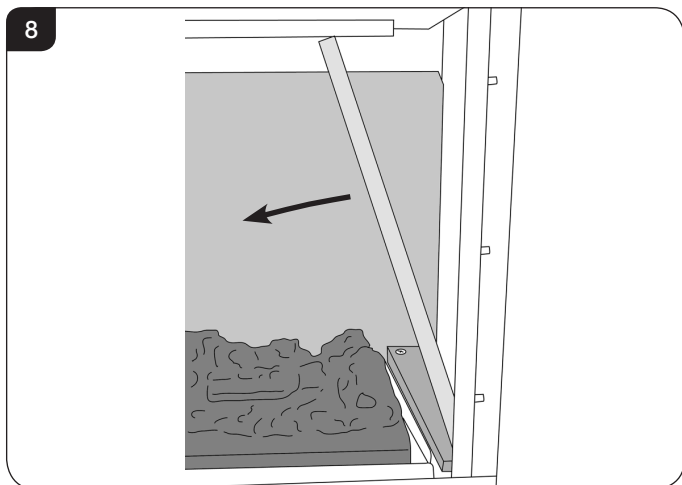

- 3.7 To remove the Left Hand liner first tilt inwards towards the centre of the firebox before lifting up and pulling out through the front of the firebox, see Diagram 8.

The 2 side liners also support the rear liner. Taking out the side liners will allow the rear liner to drop down so ensure it is supported.

- 3.8 Remove the back liner by carefully lifting over the bottom bracket and twisting slightly to allow it to be removed through the front of the appliance, see Diagram 9.

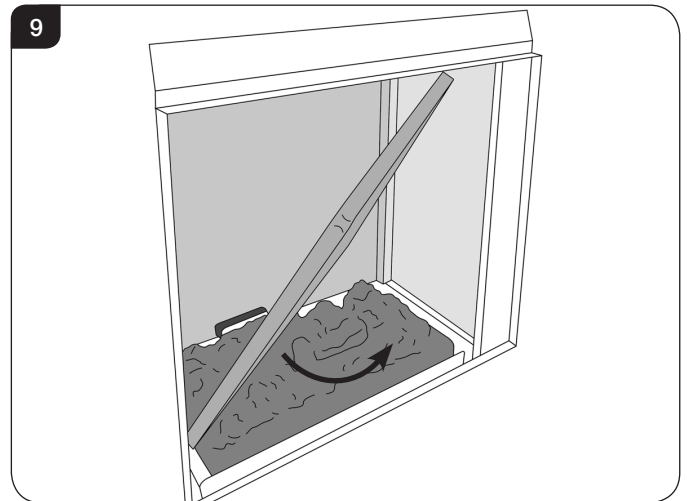

- 3.9 With the liners and baffle removed the firebox is clear for cleaning and maintenance, see Diagram 10.

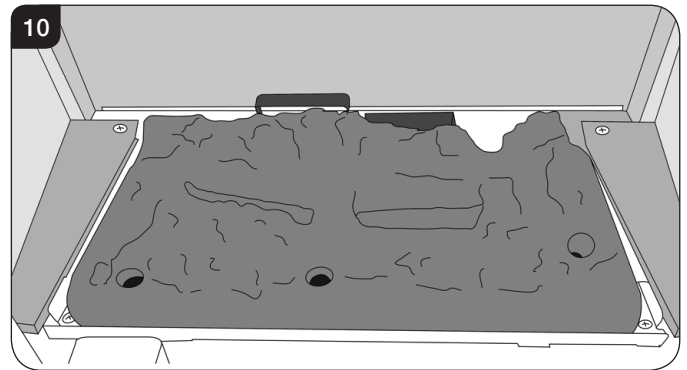

- 3.10 To replace the liners and baffle reverse these procedures.

4. Main Burner

- 4.1 To remove the frame from the appliance please refer to the separate instructions supplied with the frame.
- 4.2 Remove the door, see Section 2.
- 4.3 Remove the baffle and vermiculite liners, see Section 3.
- 4.4 Undo the screws to remove the metal side covers, see Diagram 11.
- 4.5 Turn the gas supply off at the isolation device.

Servicing Instructions - Replacing Parts

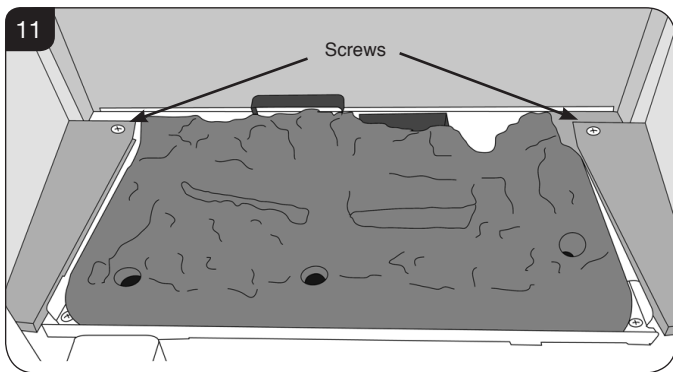

When replacing the covers, ensure that the front tab engages with the slot in the front flange of the appliance.

HAVE YOU ISOLATED THE GAS SUPPLY?

- 4.6 Disconnect the isolating device from the appliance inlet pipe to isolate the gas supply, see Diagram 12.

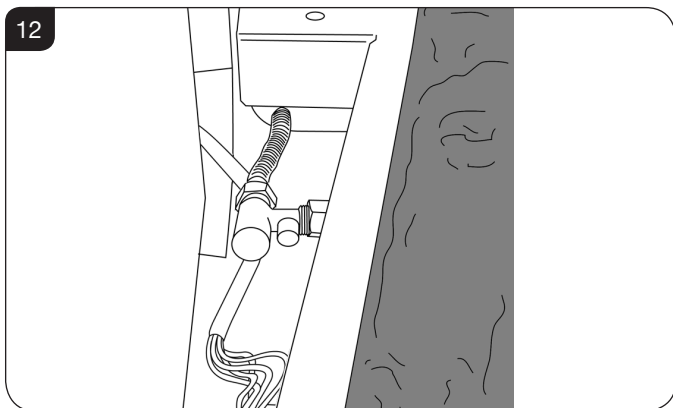

- 4.7 Remove the 2 screws at the front of the burner tray, see Diagram 13.
TAKE CARE NOT TO DAMAGE THE FUELBED WHEN REMOVING THE SCREWS.

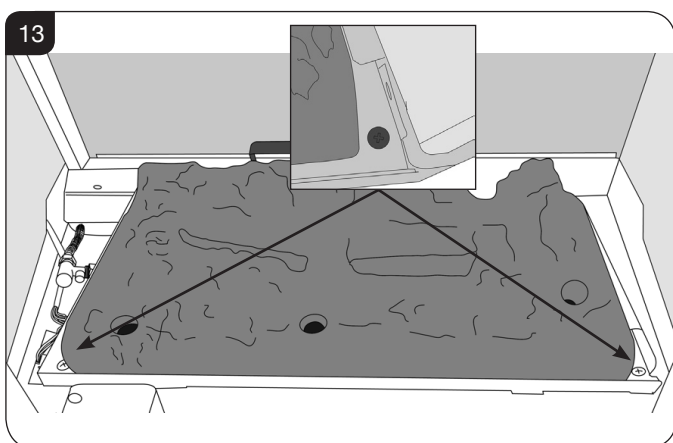

- 4.8 Hold the burner tray at the front, lift the right side up, rotate forward and carefully remove the fuel bed. Place safely to one side.
- 4.9 First disconnect the battery supply cable and then the touch pad control cable from the control box.
- The burner unit can now be serviced.

5. Pilot Unit Assembly

- 5.1 The pilot assembly is a complete unit and needs to be replaced as a unit.
- 5.2 Remove the main burner, see Section 4.
- 5.3 Turn the burner over and place on a soft surface so as to not damage the unit.

Nat Gas Versions Only

- 5.4 Undo the compression nut from the pilot pipe, see Diagram 14.

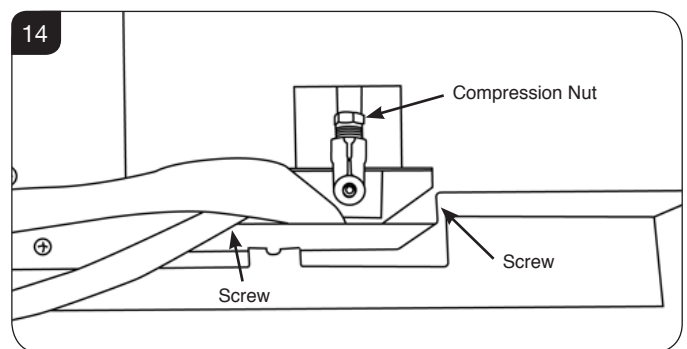

- 5.5 Undo the 2 screws to remove the pilot shield, see Diagram 14.
- 5.6 Remove the ignition lead from the electrode, see Diagram 15.
- 5.7 Undo the 2 retaining screws from pilot unit bracket, see Diagram 15.
- 5.8 Undo the thermocouple nut from the interrupter block at the rear of the gas valve, see Diagram 21.

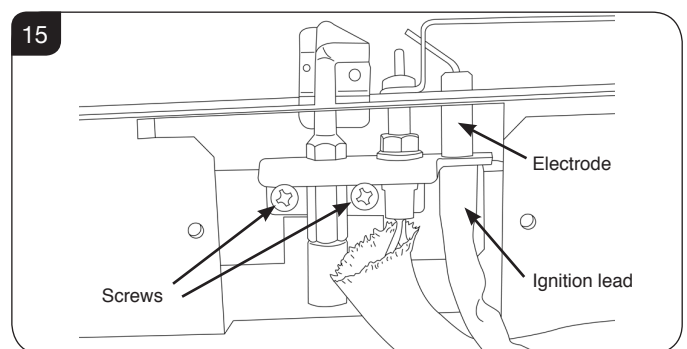

- 5.9 When replacing the pilot ensure the thermocouple follows its original route.

Servicing Instructions - Replacing Parts

5.10 Set the spark gap, see Diagram 16.

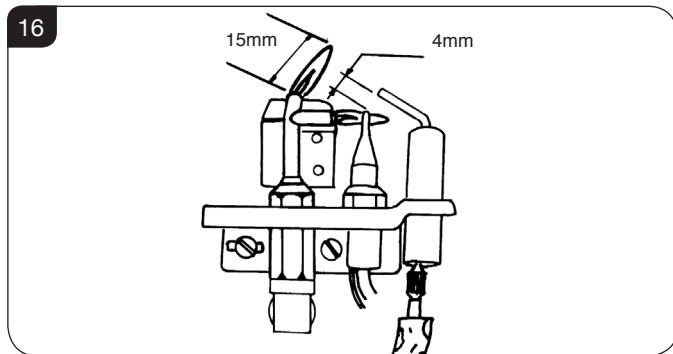

LPG Versions Only

5.11 Remove the 6 screws to remove the pilot cover, see Diagram 17.

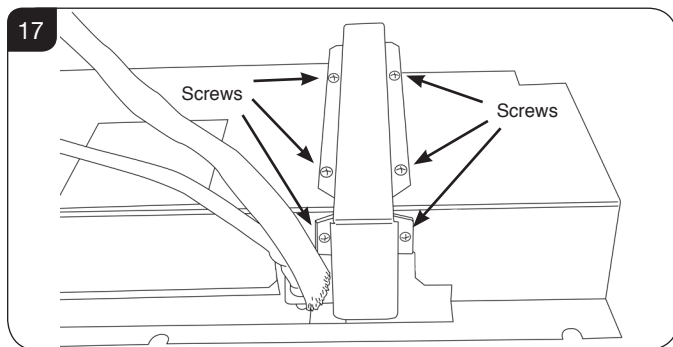

5.12 Undo the compression nut from the pilot pipe, see Diagram 18.

5.13 Remove the ignition lead from the electrode, see Diagram 18.

5.14 Undo the 2 retaining screws from pilot unit bracket, see Diagram 18.

5.15 Undo the thermocouple nut from the interrupter block at the rear of the gas valve, see Diagram 21.

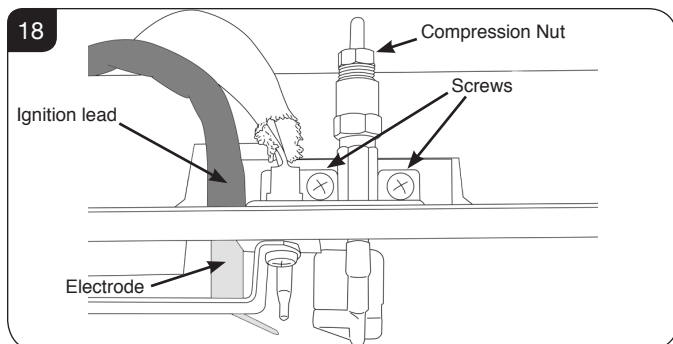

5.16 When replacing the pilot ensure the thermocouple follows its original route.

5.17 Set the spark gap, see Diagram 16.

6. Ignition Lead

6.1 Remove the main burner, see Section 4.

6.2 Remove the pilot shield by removing the 2 screws.

6.3 Disconnect the ignition lead from the electrode, see Diagram 15 and from the control box, see Diagram 19.

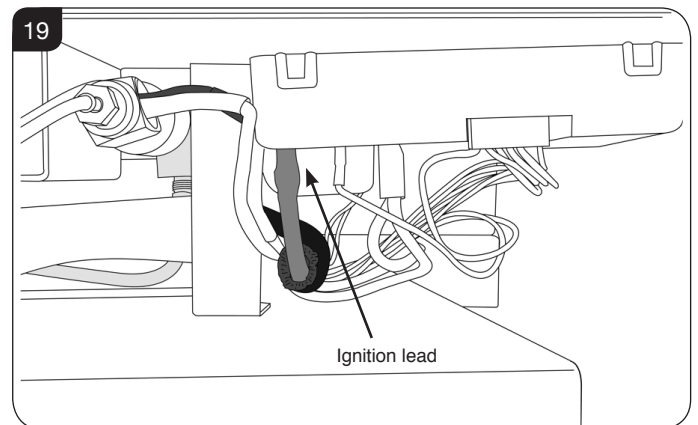

6.4 Replace with a new ignition lead following the original route. Refit the Vidaflex cover over the lead. Ensure the cover engages fully over the electrode.

6.5 Check the operation of the new ignition lead.

6.6 Replace the pilot shield.

6.7 Replace the main burner.

7. Gas Valve

7.1 Remove the burner module as described in Servicing, Replacing Parts, Section 4.

7.2 Turn the burner over and place on a soft surface so as to not damage the unit.

7.3 Disconnect the inlet pipe and feed pipe from the gas valve only, see Diagram 20.

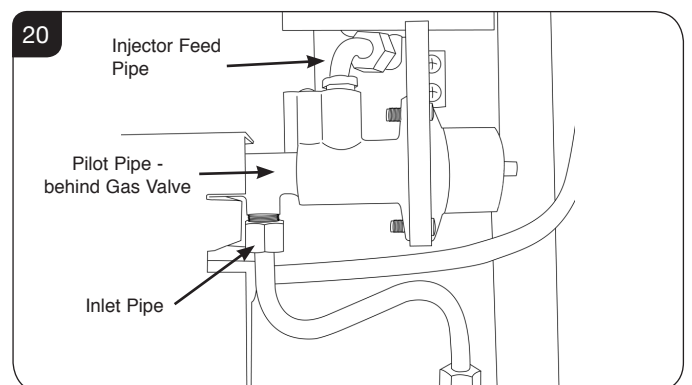

Servicing Instructions - Replacing Parts

- 7.4 Disconnect the pilot pipe from the gas valve only, see Diagram 21.

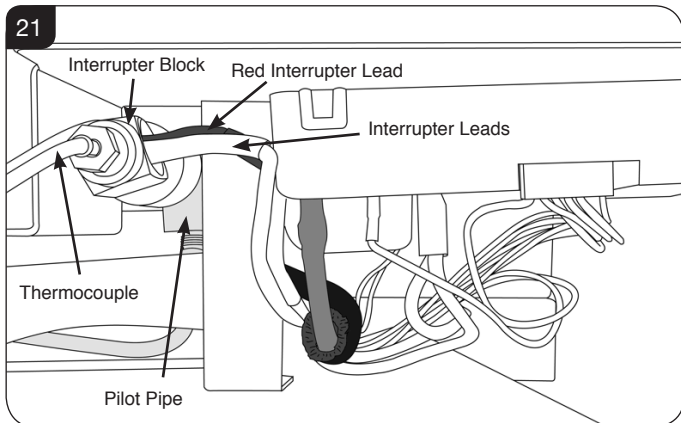

- 7.5 Disconnect the thermocouple, interrupter lead and interrupter block, see Diagram 21.

When replacing the interrupter leads ensure that the red lead locates nearest the valve, see Diagram 21.

- 7.6 Remove the Stepper motor harness from the control box, see Diagram 25.
- 7.7 Undo the 2 screws to release the valve off the bracket, see Diagram 22 A.

DO NOT UNDO THE 2 SCREWS AT THE FRONT OF THE VALVE. THEY WILL REMOVE THE MOTOR FROM THE BODY.

NOTE: There is an earth wire attached to one of the fixing screws This must be replaced back in this position.

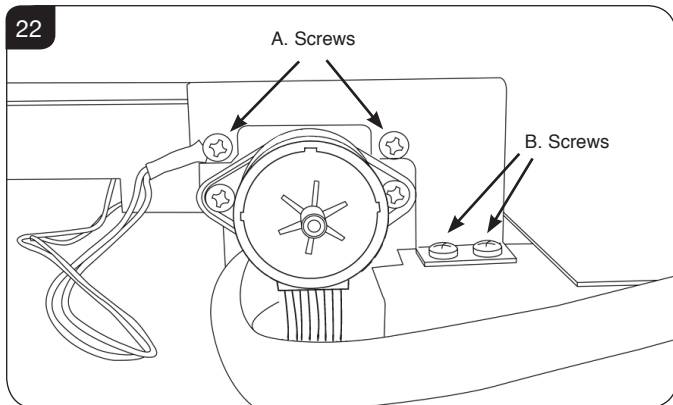

- 7.8 Undo the 2 screws to remove the bracket, see Diagram 22 B.
- 7.9 Gently remove the valve.
- 7.10 Replace in reverse order and refit the burner module.
- 7.11 Check all joints for leaks, check the operation of the thermocouple and ignition lead.

8. Magnetic Safety Valve

- 8.1 Remove the burner module, see Section 4.
- 8.2 Remove the gas valve, see Section 7.
- 8.3 Undo the mag valve retaining nut and gently tap out the mag valve and replace with a new unit. Replace the retaining nut and tighten, see Diagram 23.

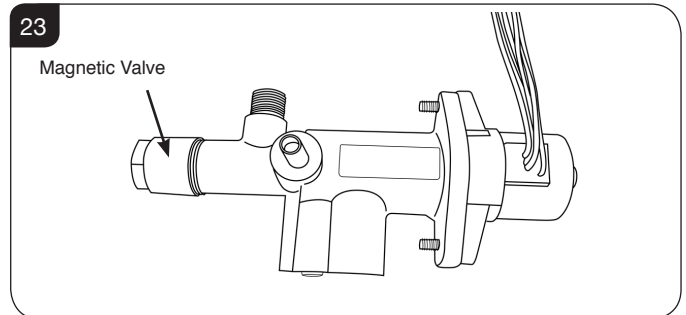

- 8.4 Reassemble the gas valve. Check for leaks after reassembly. Ensure the interrupter leads are in the correct orientation, red lead nearest the valve body.

9. Control Box

- 9.1 Undo the screws holding the control box, see Diagram 24.

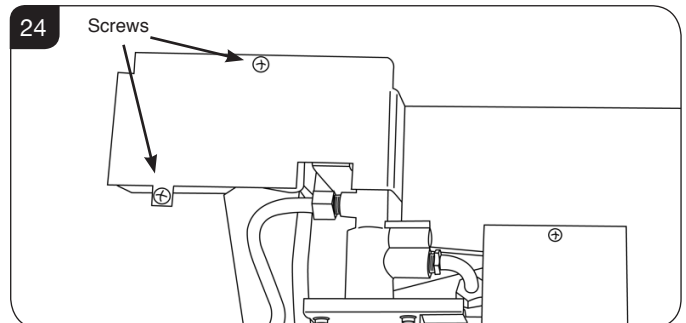

- 9.2 Disconnect from the control box:
- Ignition lead
 - Interrupter leads
 - Earth connection
 - 7-way stepper motor plug
 - The battery power supply cable
 - The touch pad control cable

See Diagram 25 for details.

Servicing Instructions - Replacing Parts

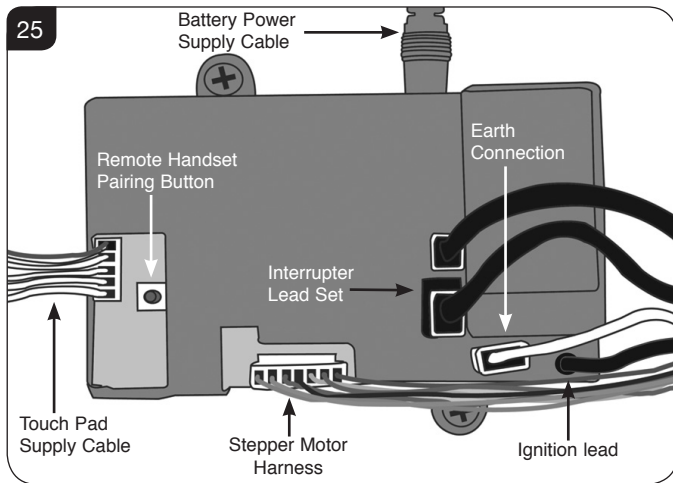

The control box can now be replaced.

- 9.3 After replacing the control box ensure all cables connections are refitted, see Diagram 26.

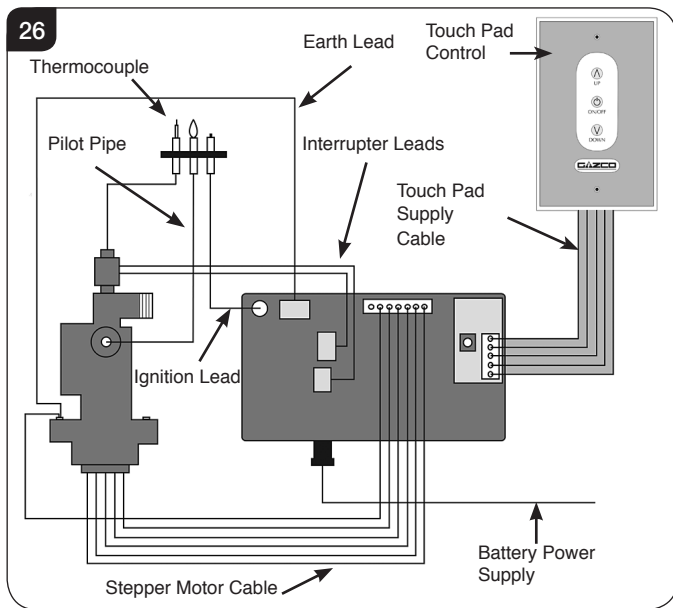

- 9.4 Prior to re-connection of the control box to the appliance, if there is no communication between the remote handset and the appliance, or if the handset is replaced, it will be necessary to pair the handset with the appliance, see Commissioning Section 2.
- 9.5 Ensure batteries are fitted and working in the handset.
- 9.6 Re-fit the touch pad control cable and the battery power supply cable to the control box.

10. Main Injector

- 10.1 Remove the burner module, see Section 4.
- 10.2 Undo the 2 screws to remove the cover plate, see Diagram 27.

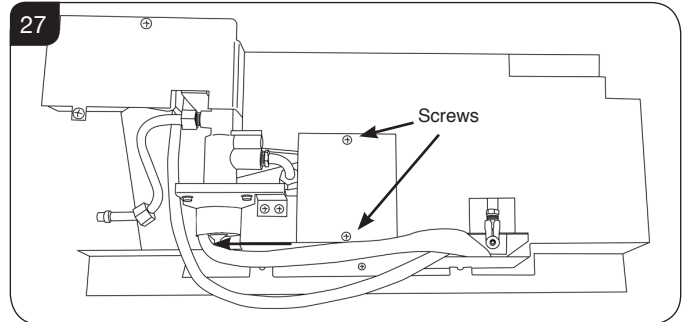

- 10.3 Remove the Aeration plate by undoing the 2 nuts that hold the plate in place, see Diagram 28.

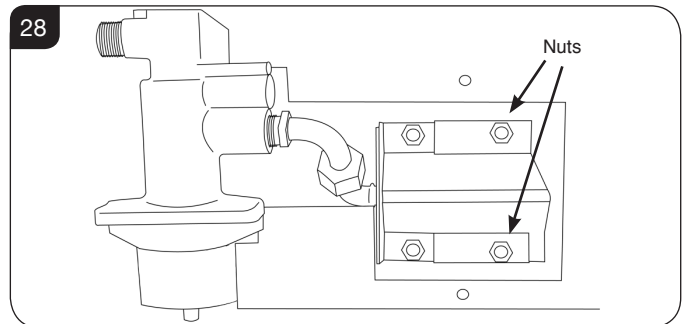

- 10.4 Undo the feed pipe nut at the valve and lock nut, see Diagram 29.

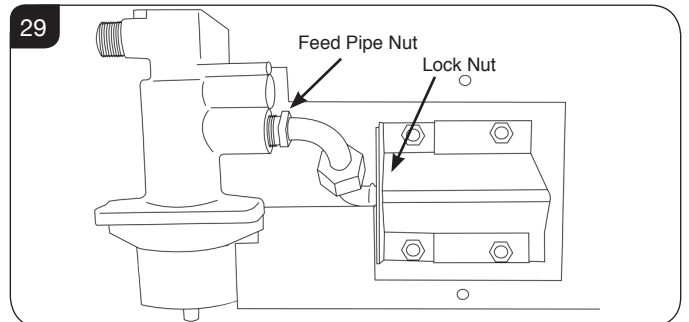

- 10.5 Remove the 2 screws attaching the valve bracket to the splitter plate, this allows the valve to be moved across in order to remove the feed pipe and injector.
- 10.6 Undo the injector nut to remove the injector from the feed pipe.

The injector can now be replaced.

Note: When reconnecting the injector to the feed pipe ensure that they are not offset.

- 10.7 Reassemble in reverse order.

Servicing Instructions - Replacing Parts

11. Primary Aeration Plate

- 11.1 Remove the burner module, see Section 4.
- 11.2 Undo the 2 screws to remove the cover plate, see Diagram 26.
- 11.3 Remove the 2 fixing nuts and slide the plate off the venturi, see Diagram 27, the Aeration Plate can now be replaced.

12. Changing Between Gas Types

In order to change between gas types, it will be necessary to change the complete burner module:

NG: GZ10440N
LPG: GZ10440P

Always quote the Model number and Serial number when ordering any spare parts.

13. Debris Area Access

- 13.1 Remove the frame from the appliance by referring to the separate instructions supplied with the front.
- 13.2 Remove the door, see Section 2 and the fuel bed components. Place carefully to one side.
- 13.3 Remove the baffle and liners, see Section 3.
- 13.4 Remove the main burner, see Section 4.
- 13.5 Undo the screws and remove the convector air panel to access the debris access panel, see Diagram 30.

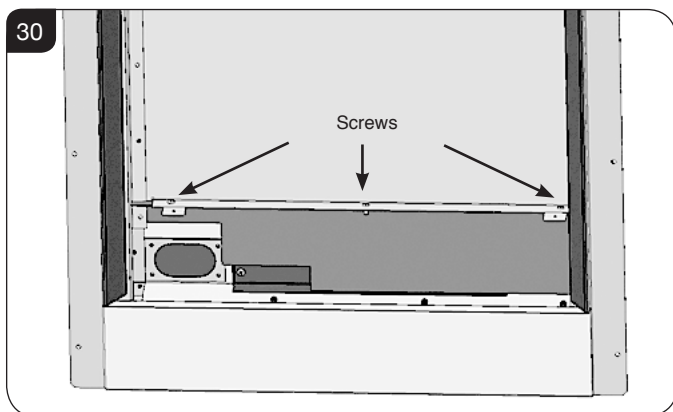

- 13.6 Undo the 7 screws to remove the debris access plate, see Diagram 31.

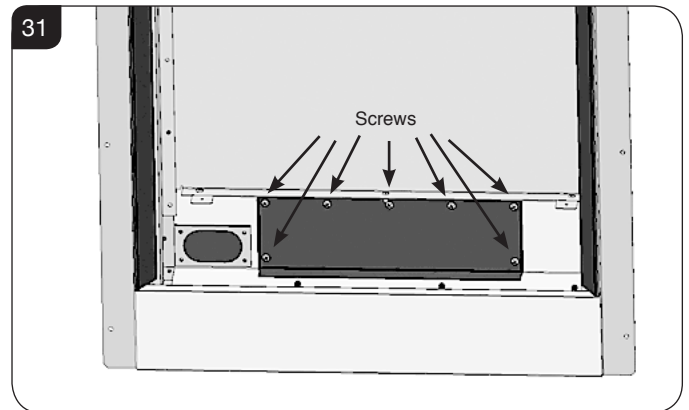

- 13.7 Clean out the debris.
- Reassemble in reverse order.

Servicing Instructions - Replacing Parts

14. Short Spares List

COMPONENT	Riva2 500	
	NG	LPG
PILOT	PI0044	PI0048
MAIN INJECTOR	IN0045	IN0068
BURNER UNIT	GZ9963	GZ9963
AERATION PLATE	G20 - GZ10406	G31 - GZ10410
GAS VALVE	GC0170	GC0172
MAG UNIT	GC0109	
IGNITION LEAD	EL0508	
CONTROL BOX	EL0575	
REMOTE CONTROL	EL0574	
INTERRUPTER BLOCK	GC0026	
INTERRUPTER LEADS	EL0316	
WALL PLATE	EL0501	
WALL PLATE CABLE 3M	EL0504	
BATTERY HOLDER	EL0503	
TOUCH PAD, BATTERY, WALL PLATE & LEAD	EL0502	
BLACK REED LINING SET	934-005	
VERMICULITE LINING SET	934-021	
BRICK EFFECT LINING SET	934-030	
LOG SET	CE1058	
EMBERGLOW	8471	
WINDOW FRAME ASSEMBLY	GZ9789	

Service Records

1ST SERVICE

Date of Service:.....

Next Service Due:.....

Signed:.....

Retailer's Stamp/Gas Safe Registration Number

3RD SERVICE

Date of Service:.....

Next Service Due:.....

Signed:.....

Retailer's Stamp/Gas Safe Registration Number

5TH SERVICE

Date of Service:.....

Next Service Due:.....

Signed:.....

Retailer's Stamp/Gas Safe Registration Number

7TH SERVICE

Date of Service:.....

Next Service Due:.....

Signed:.....

Retailer's Stamp/Gas Safe Registration Number

9TH SERVICE

Date of Service:.....

Next Service Due:.....

Signed:.....

Retailer's Stamp/Gas Safe Registration Number

2ND SERVICE

Date of Service:.....

Next Service Due:.....

Signed:.....

Retailer's Stamp/Gas Safe Registration Number

4TH SERVICE

Date of Service:.....

Next Service Due:.....

Signed:.....

Retailer's Stamp/Gas Safe Registration Number

6TH SERVICE

Date of Service:.....

Next Service Due:.....

Signed:.....

Retailer's Stamp/Gas Safe Registration Number

8TH SERVICE

Date of Service:.....

Next Service Due:.....

Signed:.....

Retailer's Stamp/Gas Safe Registration Number

10TH SERVICE

Date of Service:.....

Next Service Due:.....

Signed:.....

Retailer's Stamp/Gas Safe Registration Number

Gazco Limited, Osprey Road, Sowton Industrial Estate, Exeter, Devon, England EX2 7JG
Technical Customer Services: (01392) 261950 Fax: (01392) 261951
E-mail: technicalservices@gazco.com

A member of the Stovax Group

E & O E