

**portway**

**LX LUXIMA**

**SOLID FUEL HEATING STOVE**

**Multi-fuel version, and  
Wood-only version**

**INSTALLATION AND OPERATING INSTRUCTIONS**

**LEAVE THIS DOCUMENT WITH THE HOUSEHOLDER!**



All Portway Stoves exceed the safety and performance requirements of European Standards Intermittent burning solid fuel roomheaters for installation with a single dedicated chimney. Independently tested by SGS Nederland BV, authorised laboratory No0608, July 2018

Fuel	Wood (Beech) Multi-fuel configuration with grate and ashpan	Wood (Beech) Wood-only configuration with flat fuel bed	
Test Standard	EN 13240:2001+A2 2004	EN 13240:2001+A2 2004	
Test Cycle	1.15kg over 0.75hrs	1.15kg over 0.75hrs	
Settings	Primary 0, 2nd 1/3 open		
Flue Draught Pa (ins WG)	12 (0.05)	12 (0.05)	
Efficiency %	75.4	74.3	
Recommended Rating kW	4.9kW	4.9kW	
Mean Flue Gas Temp Rise °C	292	261	
Minimum air entry requirement	2700 mm <sup>2</sup>		
Minimum Clearance to combustibles (allow min 50mm clearance to non-combustibles)	800mm		
Emissions as if O <sub>2</sub> =13%	NO <sub>x</sub> mg/m <sup>3</sup>	120	149
	CO %	0.07	0.12
	CxHy mg/m <sup>3</sup>	52	95
	Gas flow g/sec	4.6	4.6
	Smoke Emission mg/m <sup>3</sup>	37	34

*Glyn Hughes*

I declare that this information is true, these products meet the requirements of Harmonised Standards and are fit for sale. Signed on behalf of the manufacturer by Glyn Hughes, Design Engineer, at Winster, Derbyshire, England 5. Sep. 2018

**Read these instructions! Use only recommended fuel!**

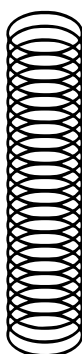

This document, when completed by the installer, constitutes part of a 'Hearth Notice' for purposes of Building Law. It must be left with the householder and placed where it can easily be found.  
**INSTALLED AT LOCATION:**

BY:

EMERGENCY CONTACT:

I definitively assert that this installation is safe, has been lit and demonstrated to the householder, conforms with current building regulations and with these instructions

SIGNED:

DATE:

Flue Draught  
measured on  
commissioning:

	Pa
	WG

Fuel used on  
commissioning

--



**TO FIND A QUALIFIED INSTALLER, FUEL SUPPLIER or CHIMNEY SWEEP,  
CONTACT:**

**UK:** The Solid Fuel Association, 7 Swanwick Court, Alfreton, Derbyshire DE55 7AS  
Tel:0845-601-4406 [www.solidfuel.co.uk](http://www.solidfuel.co.uk)

**RoI:** Irish Nationwide Fireplace Organisation, 162 Capel Street, Dublin 1 Tel:01-801-5959 [www.fireplace.ie](http://www.fireplace.ie)

**BFM Europe**

BRITISH FIRE MANUFACTURERS

Trentham Lakes, Stoke on Trent, Staffordshire, England ST4 4TJ  
[www.bfm-europe.com](http://www.bfm-europe.com) Tel 01782 339000 Fax 01782 339009

**These Portway stoves may be used in smoke control areas when operated strictly in accordance with these instructions and with Soliftec Smoke Advice Sheet No1 ([www.soliftec.com/smokeadvice.htm](http://www.soliftec.com/smokeadvice.htm)), when burning:**

**UK:** Untreated wood logs or authorised smokeless fuels (*Exempted from s20 of the Clean Air Act 1993*)

**RoI:** Wood logs, smokeless fuels or peat briquettes, but not petroleum coke (*Control of Atmospheric Pollution Regulations, 1970*)

**THIS APPLIANCE BECOMES EXTREMELY HOT AND CAN PRODUCE POISONOUS GASES.**

A fire-guard should be used if children or the infirm are present. The installer is required to EXACTLY follow these instructions and to completely comply with all local, national and international standards.

Building regulations are available at [www.soliftec.com](http://www.soliftec.com)

**INSTALLING** a stove is a 'controlled service', the law expects that it is either supervised by a qualified installer or that the building inspector is informed. Check with your local authority.

**ASBESTOS:** Your stove does not contain asbestos, but take care to avoid disturbing asbestos in an old installation.

**WEIGHT:** Your stove is heavy - take great care when moving it and ensure that the intended fireplace can support the weight- consider fitting a load distributing plate.

**YOUR CHIMNEY,** by becoming warm, makes the gas inside it rise, pulling fresh air into the stove to make it work. It must:

- Generate a draught in use of at least 12Pa (0.05ins wg)
  - Be capable of withstanding the temperatures generated.
  - Be absolutely incapable of leaking fumes into the dwelling
- This may commonly be achieved by it:
- Being at least 5m high.
  - Terminating at least 1m above any roof ridge.
  - Having an internal cross-section equivalent to not less than 125mm diameter for No1, No2 and Inset models, 150mm dia for No3, and never more than 0.14m<sup>2</sup> (eg 375 x 375mm)
  - Being free from even the slightest crack or source of leakage.
  - Having no bends sharper than 45°.
  - Being swept and entirely free of obstructions
  - Being connected only to this one appliance.
  - Being of thick masonry or otherwise adequately insulated.
  - Conforming to local building regulations.

Special rules apply where the flue passes through timber, thatch or other vulnerable materials- take specialist advice.

Although it is possible to access the chimney through the fire with the throat plate removed, fit hatches to provide access if needed.

**YOUR FIREPLACE:** Stoves become VERY hot, the installer must specify a fireplace which will completely protect the building against fire. A solid masonry hearth >12mm thick, extending at least 250mm in front of the stove, 100mm at the sides is likely to suffice, but other configurations are possible at the discretion of the expert installer. Even beyond the safety clearances given on the front page items can still become very hot - take great care in siting wax, paper etc.

**AIR SUPPLY:** Your stove needs air to breathe - there must be a permanent fresh air supply into the space in which it is installed equal to 550mm<sup>2</sup> for each kW of nominal output. This can often be provided by air leaking around door frames etc. (it is commonly accepted that this alone may suffice for appliances <5kW) but in any case of doubt, fit a purpose-made air vent. An extractor fan, or another fuel-using appliance in the same building, can remove this air.

Your Luxima stove has a built-in 'Proximity Air Supply' - a feature of Portway stoves since Victorian times which supplies precisely the required amount of air for combustion and, when the fire is lit, also circulates warmed fresh air without draughts. air. Fix the rear connector to standard 100mm flexible tube and an open outside air grille to fully conform to air supply requirements.

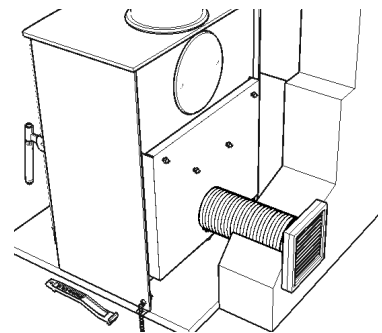

**FITTING**

Your stove can be sealed to the chimney using a short length of 125mm uninsulated pipe in several ways, two of which are shown.

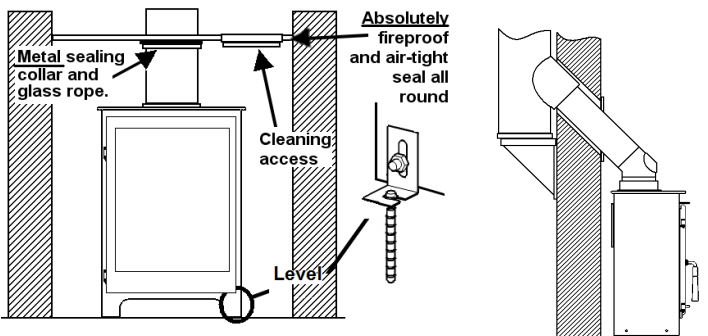

Through **steel or concrete** closure plate (with cleaning door) into old, oversized, chimney. Steel sealing collar. Hearth fixings also shown.

45° top outlet sleeved through wall into external insulated flue. Cleaning hatches on bends.

The Luxima is available in two different firebox configurations:

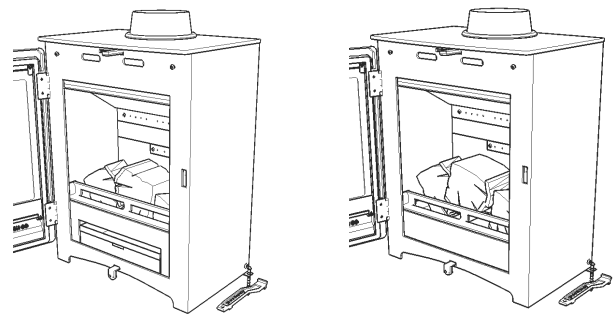

(L) Multi-fuel version with grate and ashpan, can burn wood logs and the full range of authorised smokeless fuels.

(R) Wood-only version, burns wood logs only

Whichever model and method is used it is **imperative** that: (1) The route for gases from the stove to the chimney terminal is **completely** air-tight; even the tiniest gap or crack can spoil the updraught. Seal all joints with fireproof cement and/or heatproof rope. (2) It is possible to sweep the entire length- access doors may be required. (3) The entire construction is of durable fireproof materials. (4) **Fit a suitable CO alarm!**

**CHECK THE INSTALLATION !**

Make sure that the stove is fully assembled and sealed. Check that the **inner steel baffle** (shown dark on this cutaway diagram (right)) is correctly and securely fitted in place as shown.

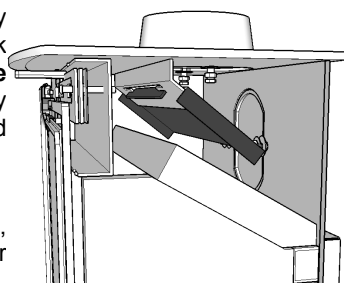

Once installed, light the fire, demonstrate it to the householder and check that:

- 1) It burns controllably and does not emit fumes to the room
- 2) The route for gases from the stove to the chimney terminal is completely airtight, unobstructed and able to be swept.
- 3) The entire construction is of durable fireproof materials.
- 4) The flue presents a draught in use of at least 12Pa

**LIVING WITH YOUR STOVE**

Every fuel, chimney and condition of use is different. Only experience will show which are the best settings for you.

**LIGHTING** If lighting after a period of non-use, do check that the

flueways and chimney are completely clear. Empty the ashes. Place two or three firelighters close together, or screwed-up paper covered with dry sticks, at the back of the grate and light them. When they are burning well gently fill the fire with dry fuel, close the door and set the air control slides to the 'high' (right) position. When the fire is burning well, move the controls to the lowest practical setting.

**FILLING:** Don't fill above the level shown in the diagram.

**CONTROL** How fast the fire burns depends on how much air reaches the fuel. The stove has two air controls, one below the window ('primary' 1) and one above ('airwash control 2). Move the top slides to the right for highest output, to the left for 'low'. The lower control is 'in' for low and 'out' for high. They can get very hot, so move them only with the handle supplied.

Our tests indicate highest efficiency on wood with the primary (1) control closed and the airwash (2) at 2/3 open, but the precise settings to suit your fuel and chimney can only be found from experience.

**EMPTYING ASHES:** Use the tool or glove to open the door and ...  
**Multifuel model:** Stir the fire with a poker. Use the tool to lift out the ashpan. Never allow ash to build up so as to touch the underside of the grate. **Wood-only model:** Empty excess ash using a spoon or scoop only when it is so full as to risk spilling over the firebars. **All:** Remember to let ash cool before disposing in plastic sacks or dustbins.

**KEEPING THE WINDOW CLEAN** Simply operating the stove for a few minutes at high output will often burn-off any deposits left by tarry or wet fuel. Severe stains can be removed when cold with a domestic bleach cleaner. The window is not glass but a transparent ceramic, it may develop tiny hairline cracks, these are harmless, and a characteristic of the toughest and most heat-resistant material known. Reduce the risk of staining by using only *very dry* fuel.

**OPENING THE DOOR** This stove is designed to be operated only with the door closed. Open the door very slowly to minimise fume emission and prevent hot fuel falling out. Remember that the whole stove becomes extremely hot.

**SUMMER SHUT DOWN:** Before a long period of non-use, empty fuel and ash, remove the throat plate and leave all the air controls open to allow ventilation to reduce condensation.

## FUELS

Do avoid dusty materials like sawdust, they can burn far too violently.

**SMOKE CONTROL:** In certain areas special rules apply to reduce smoke nuisance. Check with your local authority.

**WOOD** only emits as much carbon to the atmosphere as the tree took in when growing, so wood is considered the 'carbon neutral' fuel. When wood is cut down its cells are full of water. Burning such wet or 'green' wood wastes heat in making steam and produces flammable, acidic tars which will cling to, and rapidly damage, your stove and chimney. Split logs will typically take two years to become reasonably dry, round logs very much longer. Cracks in the ends, a hollow sound when tapped and bark falling away are all signs that a log may be ready for use. The fine, white residue produced when wood burns is not ash, but the remains of cell walls which can burn if kept hot enough, so don't de-ash the fire until absolutely necessary when using wood.

For best performance, and *always* for low smoke emission:

Split logs lengthways for drying

- Use logs no bigger than about 100mm x 250mm
- Ensure logs are absolutely dry (less than 20% moisture)
- Fill the stove criss-cross, so air can circulate between logs.
- Fill 'little and often'
- Always have the airwash control (2) at least a little open.

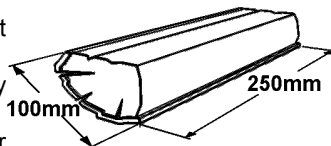

- When first lighting, or reviving a fire from embers, use only very small, thin, dry, sticks.

**JOINERY WASTE** Dry wood offcuts will burn well, but don't expect softwood waste to burn as cleanly or for as long as hardwood logs.

**OTHER FUELS** With the multi-fuel grate and ashpan fitted, this stove can burn a wide range of other fuels, including the full range of authorised smokeless fuels, as recommended by your fuel supplier and permitted in your region.

**HOUSEHOLD WASTES** Some plastics give off toxic fumes when burned and remember that batteries and aerosols explode! The stove is not an incinerator, so only ever use the recommended fuels and NEVER use liquid fuels in any form.

**DO NOT USE** Don't use non-authorised 'smokeless fuels' or 'petcoke' - these are often made with dangerous high-sulphur oil waste and will rapidly damage your stove. Don't use cheap, raw bituminous coal, sometimes sold as 'Polish Coal'.

## PROBLEMS?

Problems like those listed here are usually due to some difficulty with the installation, chimney or fuels, so please check back through this leaflet carefully. If necessary seek specialist advice.

**SMOKE FROM THE CHIMNEY** It is quite normal for a little smoke to be emitted from the chimney when the fire is cold. Use only VERY dry wood or smokeless fuels.

**DAMAGED LINERS** The Portway stove gets very, very hot inside, it is quite usual for the replaceable liners to crack or craze. They need only be replaced when they have almost completely disintegrated. Help them last longer by using only *very dry* fuel.

**POOR HEAT OUTPUT:** A stove can heat a typical room of *about* 12m<sup>3</sup> volume for each kW of output, so a 5kW model can heat up to (12 x 5) 63m<sup>3</sup>, a room of about 5m square. The actual size depends on the insulation and air-change ratio of the room. To attempt to heat a larger room will result in excessive fuel consumption and damaging overheating.

**LACK OF CONTROLLABILITY** Wood and some other fuels may burn excessively until the gases in them have been used up. You can reduce this effect by making sure that the fire is set to 'low' for a while before refuelling and checking that the door seals fully. Adjust the heat output by how much fuel you put on, as well as by using the controls.

**CONDENSATION** onto cool surfaces inside the stove can be severe if fuel is in any way damp. *Use only very dry fuel.*

**OVER-FIRING:** It is possible to leave the fire too long with the controls set too high leading to 'over firing', seen as glowing metal parts, excessive chimney temperature and risk of parts failing or chimney fires. Always set controls to the lowest practical setting. A chimney thermometer, from your local stove shop, can help.

**SMOKE COMING INTO ROOM** Fumes are poisonous- smoke emission must NEVER be tolerated, causes might be:

**NEW STOVE:** There is often a smell and sometimes visible fumes as the paint cures. This normally stops after an hour or so.

**INADEQUATE SEALS:** Are all flue pipes and connectors *absolutely* gas-tight? Even the tiniest crack or gap can spoil the draught. Does an inset appliances fully seal against the fireplace?

**BLOCKED THROAT PLATE:** Has soot and ash collected on the 'throat plate' above the inner back part of the firebox?

**UNSUITABLE, BLOCKED OR UN-SWEPT CHIMNEY:** The first requirement for correct operation is a sound chimney. Check the requirements earlier in this document and in any case of doubt engage a professional sweep or chimney engineer.

**POOR AIR SUPPLY:** Lack of air to the fire is a common cause of smoking and poor performance. Air supply problems may be worse in certain wind conditions (often incorrectly ascribed to 'downdraught', which is in fact very rare), where air can be sucked out of the room.

**DOWNDRAUGHT:** Wind can blow *down* a chimney if there is something higher nearby such as a tree, hill or high building. Fitting an anti-downdraught cowl to the chimney top can cure this. Types which cannot be swept through are not recommended.

**POOR CHIMNEY DRAUGHT-** Chimney draught in use **MUST** be at least 12Pa.

**CHIMNEY FIRE:** In the rare event of deposits inside the chimney igniting (roaring sound + dense smoke and sparks from the chimney) immediately close the door, shut all air controls and call the fire brigade. Prevent fires by using *very dry fuel* and having your chimney swept regularly.

## MAINTENANCE

**MONTHLY-** With the fire cold, remove, clean and refit the throat (or 'baffle') plate below the flue outlet. Check that the flue is clear and unblocked, and that the door seals are sound.

**ANNUALLY- SWEEP THE CHIMNEY** The entire length of the chimney from stove to outlet should be swept annually, more often if smoky fuels are used.

**NEW PARTS** Your stove has been extensively tested for safety - please don't try to modify it and always obtain genuine spare parts.

**SURFACE FINISH** Wipe the stove body with a slightly damp cloth when cool. NEVER use aerosol spray or wax near the hot fire – they can ignite. Painted steel parts can be refurbished using special spray paint.

Your stove generates **VERY** high temperatures. Eventually the internal parts will require replacement. Help parts to last by:

- Using only recommend, very dry, fuels.
- Cleaning the throat plate regularly.
- Avoiding 'over-firing'

## PARTS AND ACCESSORIES

When ordering parts, specify the version of the Portway LX stove you have.

Portway spares Tel. 01782 339034 Fax 01782 339028

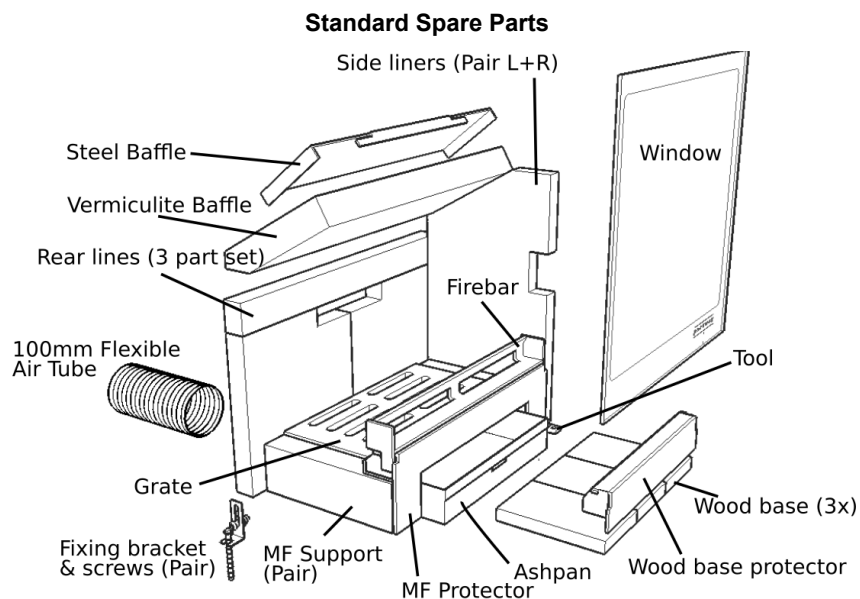

Trentham Lakes, Stoke on Trent, Staffordshire, England ST4 4TJ  
[www.bfm-europe.com](http://www.bfm-europe.com) Tel 01782 339000 Fax 01782 339009

**BFM Europe**  
 BRITISH FIRE MANUFACTURERS