



## INSTALLER AND OWNER GUIDE

# Model 956

INSET LIVE FUEL EFFECT GAS FIRE

Fitted with one of the following fascia.

**Blenheim, Whitsbury**

**Seattle** or **Siva** fascia.



We trust that this guide gives sufficient details to enable this appliance to be installed, operated and maintained satisfactorily.

However, if further information is required, our

**Valor Fires Technical Helpline** will be pleased to help.

Telephone **0844 879 35 88** (National call rates apply in the United Kingdom).

In the Republic of Ireland

Telephone **01 842 8222**.



**INSTALLER: Please leave this guide with the owner**

# INSTALLER GUIDE

**THIS APPLIANCE IS FOR USE WITH NATURAL GAS (G20).**

**WHEN CONVERTED USING CONVERSION KIT NO. 0595221 THIS APPLIANCE IS FOR USE WITH PROPANE GAS (G31).**

**THIS APPLIANCE IS SUITABLE ONLY FOR INSTALLATION IN THE UNITED KINGDOM (GB) AND THE REPUBLIC OF IRELAND (IE).**

## **GDC Group Limited.**

All rights reserved. No part of this publication may be reproduced in any material form (including photocopying), stored in any medium by electronic means (including in any retrieval system or database) or transmitted, in any form or by any means, whether electronic, mechanical, recording or otherwise, without the prior written permission of the copyright owner.

Applications for the copyright owner's permission to reproduce any part of this publication should be made, giving details of the proposed use, to the following address: The Company Secretary, GDC Group Ltd., Millbrook House, Hedge End, Southampton, SO30 2DF.

Warning: Any person who does any unauthorised act in relation to a copyright work may be liable to criminal prosecution and civil claims for damages.



Valor Fires, GDC Group Ltd., Millbrook House, Hedge End, Southampton, SO30 2DF  
[www.valor.co.uk](http://www.valor.co.uk)

**Because our policy is one of constant development and improvement, details may vary slightly from those given in this publication.**

# INSTALLER GUIDE

## Safety First.

Valor Fires fires are CE Approved and designed to meet the appropriate British Standards and Safety Marks.



## Quality and Excellence.

All Valor Fires fires are manufactured to the highest standards of quality and excellence and are manufactured under a BS EN ISO 9001 quality system accepted by the British Standards Institute.



## The Highest Standards

Valor is a member of the Benchmark scheme and HHIC (Heating and Hot water Industry Council) that work to ensure high standards of safety, quality and performance.



## Careful Installation

This gas fire must be installed by a competent GAS SAFE REGISTER operative in accordance with this installer guide.



# INSTALLER GUIDE

FOR OWNER GUIDE SEE PAGES 38 TO 52

# INSTALLER GUIDE

## CONTENTS

<u>Section</u>	<u>Heading</u>	<u>Page</u>
	<b>INSTALLER GUIDE</b>	<b>4 - 37</b>
	<b>OWNER GUIDE</b>	<b>38 - 52</b>
<b>1.</b>	<b>IMAGES</b>	<b>7</b>
<b>2.</b>	<b>SAFETY</b>	<b>8</b>
<b>3.</b>	<b>APPLIANCE DATA AND EFFICIENCY</b>	<b>9</b>
	3.1 General information.	9
	3.2 Efficiency.	9
<b>4.</b>	<b>GENERAL INSTALLATION REQUIREMENTS</b>	<b>10</b>
	4.1 Regulations, Standards and Law.	10
	4.2 Ventilation requirements.	11
	4.3 The Atmosphere sensing device (ASD).	11
	4.4 Fireguard requirements.	11
	4.5 Room considerations.	11
	4.6 Chimney preparation.	12
	4.7 Fireplace preparation.	12
	4.8 The hearth.	12
	4.9 Fireplace clearances.	13
	4.10 Installation options.	15
	4.10.1 Conventional fireplace and hearth.	15
	4.10.1.1 'Hole-in-the-wall' Installations.	15
	4.10.2 Metal flue box and hearth.	16
	4.10.3 Precast concrete or clay flue block system and hearth.	16
	4.11 Flues.	17
	4.12 Propane gas fires.	18
<b>5.</b>	<b>PACK CONTENTS</b>	<b>18</b>
<b>6.</b>	<b>FIREPLACE CHECK</b>	<b>21</b>
	6.1 Soundness for appliance attachment.	21
	6.2 Fireplace flue pull.	21
<b>7.</b>	<b>IGNITION CHECK</b>	<b>21</b>
<b>8.</b>	<b>GAS SUPPLY CONNECTION</b>	<b>22</b>
<b>9.</b>	<b>PREPARING APPLIANCE FOR INSTALLATION</b>	<b>23</b>
	9.1 Appliance preparation.	23
	9.2 Fitting the foam seal (All models).	23
	9.3 The flue restrictor.	23

# INSTALLER GUIDE

## CONTENTS (Continued)

<u>Section</u>	<u>Heading</u>	<u>Page</u>
<b>10. HOTBOX INSTALLATION</b>		<b>24</b>
10.1	Method 1- Front fixing to fireplace surround.	24
10.2	Cable retention.	24
10.3	Floor sealing.	26
<b>11. BURNER INSTALLATION</b>		<b>27</b>
11.1	Burner and supply pipe installation.	27
11.2.	Lighting the burner.	27
11.3	Operating the burner.	27
11.4	Inlet pressure check.	28
11.5	Fitting the burner tray trim.	28
<b>12. FULL OPERATING CHECKS &amp; THE BENCHMARKING SCHEME</b>		<b>28</b>
12.1	Check the control settings.	28
12.1.1	Lighting the burner.	28
12.1.2	Operating the burner.	29
12.1.3	The Benchmarking Scheme	29
<b>13. FASCIA AND FIREFRONT INSTALLATION</b>		<b>29</b>
13.1	Fitting a firefront that has not been supplied with the fire.	29
13.2	Fitting the magnetic three piece fascia trim.	30
13.3	Fitting the Blenheim firefront.	30
13.4	Fitting the Seattle/Siva firefront.	30
<b>14. SPILLAGE AND FLAME SUPERVISION CHECKS</b>		<b>32</b>
14.1	Check for spillage.	32
14.2	Flame supervision and spillage monitoring system.	32
<b>15. FINAL REVIEW</b>		<b>33</b>
<b>16. SERVICING AND PARTS REPLACEMENT</b>		<b>34</b>
16.1	Checking the aeration setting of the burner.	35
16.2	To remove the burner unit.	35
16.3	To remove the pilot unit.	36
16.4	To remove the gas valve.	36
16.5	To remove the burner.	37
16.6	To remove the main burner injector.	37
16.7	To remove the appliance from the fireplace.	37
16.8	To remove the magnetic three piece fascia.	37

# INSTALLER GUIDE

## 1. IMAGES

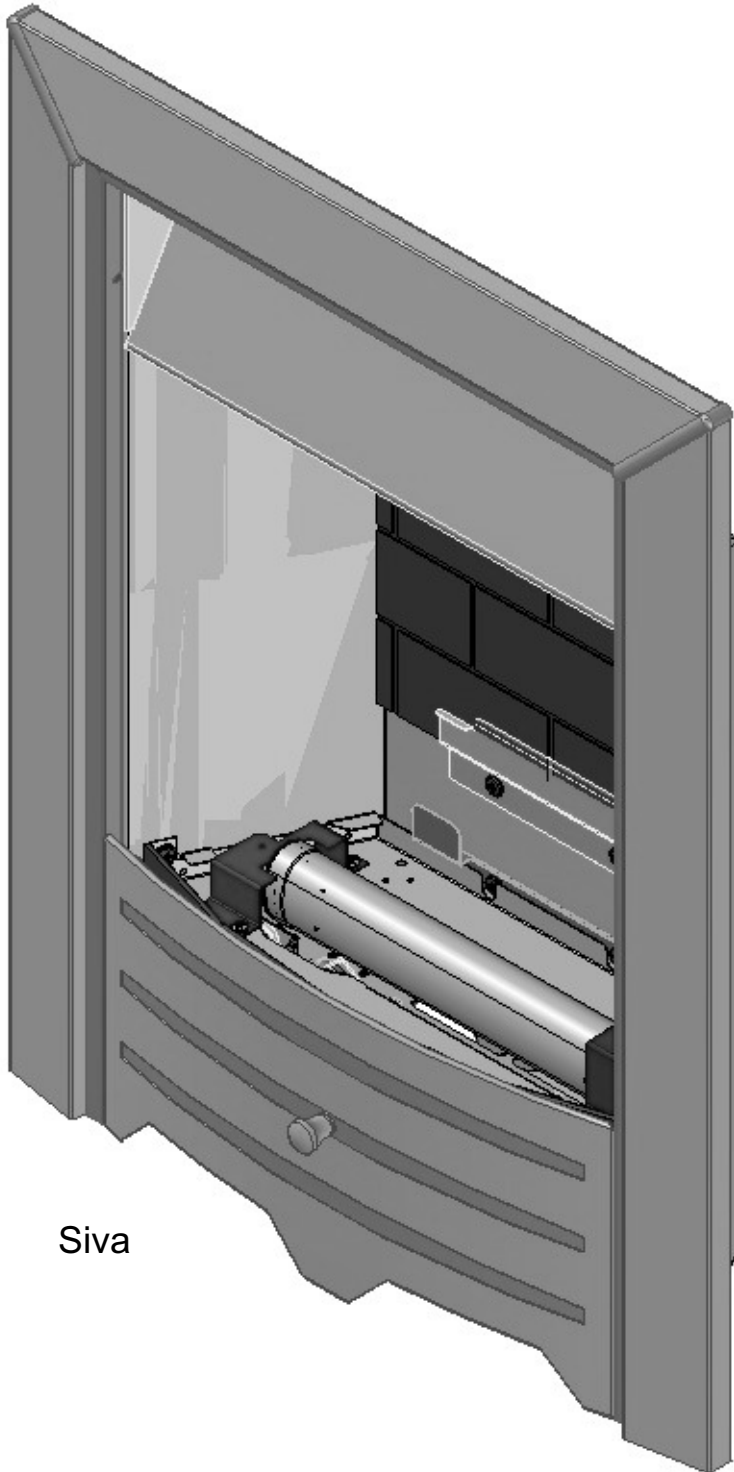

Siva

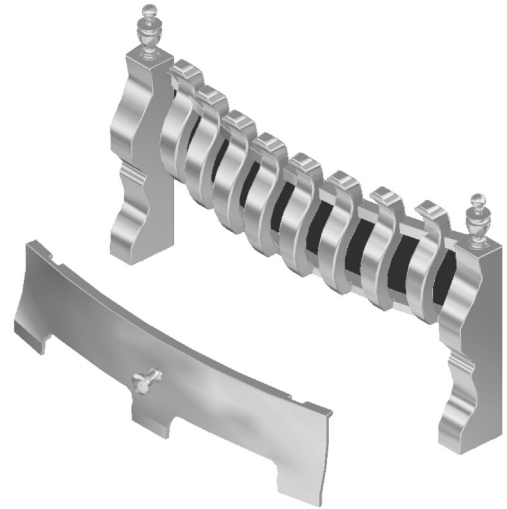

Blenheim

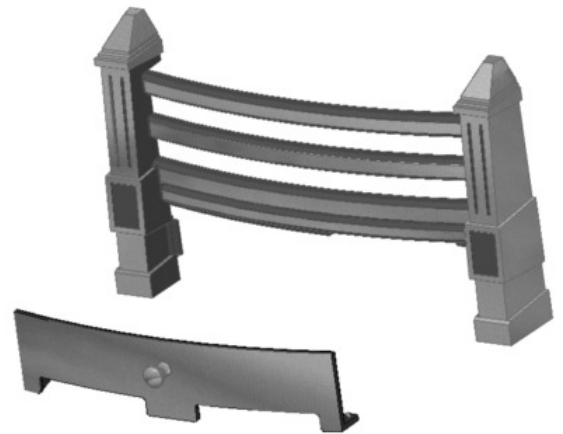

Whitsbury

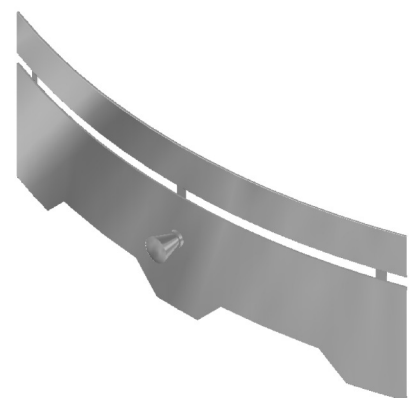

Seattle

# INSTALLER GUIDE

## 2. SAFETY

### Installer

Before continuing any further with the installation of this appliance please read the following guide to manual handling:

- The lifting weight of the appliance heat engine and hotbox is 4.4 kg. This does not include fascia or ceramics.
- One person should be sufficient to lift the fire. If for any reason this weight is considered too heavy then obtain assistance.
- When lifting always keep your back straight. Bend your legs and not your back.
- Avoid twisting at the waist. It is better to reposition your feet.
- Avoid upper body/top heavy bending. Do not lean forward or sideways whilst handling the fire.
- Always grip with the palm of the hand. Do not use the tips of fingers for support.
- Always keep the fire as close to the body as possible. This will minimise the cantilever action.
- Use gloves to provide additional grip.
- Always use assistance if required.
  
- **This product uses fuel effect pieces and a burner compartment rear wall containing Refractory Ceramic Fibres (RCF), which are man-made vitreous silicate fibres. Excessive exposure to these materials may cause irritation to eyes, skin and respiratory tract. Consequently, it is important to take care when handling these articles to ensure that the release of dust is kept to a minimum. To ensure that the release of fibres from these RCF articles is kept to a minimum, during installation and servicing we recommend that you use a HEPA filtered vacuum to remove any dust and soot accumulated in and around the fire before and after working on the fire. When replacing these articles we recommend that the replaced items are not broken up, but are sealed within a heavy duty polythene bag, clearly labelled as RCF waste. RCF waste is classed as a stable, non-reactive hazardous waste and may be disposed at a landfill licensed to accept such waste. Protective clothing is not required when handling these articles, but we recommend you follow the normal hygiene rules of not smoking, eating or drinking in the work area and always wash your hands before eating or drinking.**
- **This appliance does not contain any component manufactured from asbestos or asbestos related products.**



# INSTALLER GUIDE

## 3. APPLIANCE DATA AND EFFICIENCY

### 3.1 General information.

Gas	Natural (G20)	Propane (G31) *
Inlet Pressure	20mbar	37mbar
Input - Max. (Gross)	6.0kW (20,500Btu/h)	6.1kW (20,800Btu/h)
Input - Min. (Gross)	2.3kW (7,850Btu/h)	3.8kW (12,965Btu/h)
Input - Max. (Net)	5.4kW (18427Btu/h)	5.61kW (19147Btu/h)
Input - Min. (Net)	2.07kW (7063Btu/h)	3.50kW (11928Btu/h)
Inlet Test Pressure (Cold)	20.0 ± 1.0mbar (8.0 ± 0.4in w.g.)	37.0 ± 1.0 mbar (14.85 ± 0.4in w.g.)
Gas Connection	8mm pipe	8mm pipe
Burner Injector	Cat 82 - 069	Size 128
Pilot & Atmosphere Sensing Device	Copreci Ref. O.D.S 21500/166	Copreci Ref. O.D.S 21500/166 Fitted with RBM 180 - 02 injector
Ignition	Piezo Electric. Integral with Gas Tap	Piezo Electric. Integral with Gas Tap
Aeration	Factory set	Non-adjustable

\* When converted using Kit 0595221.

The appliance information label is located on a plate at the base of the fire. This can be seen by removing the firefront.

### 3.2 Efficiency.

The efficiency of this appliance has been measured as specified in BS 7977 - 1 and the result is as below :

<u>Model</u>	<u>Efficiency % (Gross)</u>	<u>Efficiency % (Net)</u>
956	51	56
956 when converted to LPG	52	56

The gross calorific value of the fuel has been used for this efficiency calculation. The test data from which it has been calculated has been certified by Advantica Certification services (0087). The efficiency value may be used in the UK Government's Standard Assessment Procedure (SAP) for energy rating of dwellings.

# INSTALLER GUIDE

The conversion of **net** efficiency to **gross** was achieved by multiplying the net efficiency by the following conversion factor from Table E3 of SAP 2005, rounding down to the nearest whole number.

Gas	Conversion factor from <b>net</b> to <b>gross</b> efficiency
Natural Gas	0.901
LPG	0.921

## 4. GENERAL INSTALLATION REQUIREMENTS

### 4.1 Regulations, Standards and Law.

The installation must be in accordance with these instructions.

For the user's protection, in the United Kingdom it is the law that all gas appliances are installed by competent persons in accordance with the current edition of the Gas Safety (Installation and Use) Regulations. Failure to install the appliance correctly could lead to prosecution. GAS SAFE REGISTER and CORGI require their members to work to recognised standards.

In the United Kingdom the installation must also be in accordance with:

All the relevant parts of local regulations.

All relevant codes of practice.

The relevant parts of the current editions of the following British Standards:-

BS EN 1856 Part 1 - Chimneys - Requirements for metal chimneys.

BS 715 - Specification for metal flue boxes for gas-fired appliances not exceeding 20kW.

BS EN 1858 - Chimneys - Components - Concrete flue blocks.

BS EN 1806 - Chimneys - Clay / ceramic flue blocks.

BS 5440 Part 1 - Installation of flues.

BS 5440 Part 2 - Installation and maintenance of flues and ventilation for gas appliances of rated input not exceeding 70 kW net (1st, 2nd and 3rd family gases).

BS 6461 Part 1 - Masonry chimney & flues - Installation

BS 1251 - Fireplace components

BS 5871 Part 2 - Installation - Inset LFE gas fires

BS 6891 - Gas pipework installation

– In England and Wales, the current edition of the Building Regulations issued by the Department of the Environment and the Welsh Office.

– In Scotland, the current edition of the Building Standards (Scotland) Regulations issued by the Scottish Executive.

– In Northern Ireland, the current edition of the Building regulations (Northern Ireland) issued by the Department of the Environment for Northern Ireland.

# INSTALLER GUIDE

– In the Republic of Ireland the installation must be carried out by a competent person and installed in accordance with:

- a) The current edition of IS 813 “Domestic gas installations”.
- b) All relevant national and local rules in force.
- c) The current building regulations

Where no specific instructions are given, reference should be made to the relevant British Standard Code of Practice.

## **4.2 Ventilation requirements.**

Normal adventitious ventilation is usually sufficient to satisfy the ventilation requirements of this appliance. In GB reference should be made to BS 5871 Part 2 and in IE reference should be made to the current edition of IS 813 “Domestic Gas Installations” which makes clear the conditions that must be met to demonstrate that sufficient ventilation is available.

## **4.3 The Atmosphere sensing device (ASD).**

The appliance is fitted with an A.S.D (Atmosphere sensing device). If the appliance closes down after a period of operation for no apparent reason, the consumer should be informed to stop using the appliance until the installation and appliance have been thoroughly checked. The A.S.D will shut the appliance down if an unacceptable amount of harmful products of combustion accumulate. Under no circumstances should the A.S.D be altered or bypassed in any way. Only a genuine manufacturer’s replacement part should be fitted. The individual A.S.D components are not replaceable.

## **4.4 Fireguard requirements.**

A fireguard complying with BS 8423 should be fitted for the protection of young children, the elderly, the infirm and pet animals.

## **4.5 Room considerations.**

**4.5.1** This appliance must not be installed in any room that contains a bath or shower or where steam is regularly present.

**4.5.2** An extractor fan may only be used in the same room as this appliance, or in any area from which ventilation for the appliance is taken, if it does not affect the safe performance of the appliance. Note the spillage test requirements detailed further on in this manual. If the fan is likely to affect the appliance, the appliance must not be installed unless the fan is permanently disconnected.

**4.5.3** Note that soft wall coverings (e.g. embossed vinyl, etc.) are easily affected by heat. They may scorch or become discoloured when close to a heating appliance. Please bear this in mind when installing.

# INSTALLER GUIDE

## 4.6 Chimney preparation.

**4.6.1** If the appliance is intended to be installed to a chimney that was previously used for solid fuel, the flue must be swept clean prior to installation. All flues should be inspected for soundness and freedom from blockages.

**4.6.2** Any chimney damper or restrictor should be removed. If removal is not possible, they must be secured in the open position.

## 4.7 Fireplace preparation.

**4.7.1** If the fireplace opening is an underfloor draught type, it must be sealed to stop any draughts.

**4.7.2** The fireplace floor should be reasonably flat to ensure that the hotbox can be installed without it rocking and so that a good seal can be made at the bottom front of the box.

**4.7.3** The front face of the fireplace should be reasonably flat over the area covered by the hotbox top and side flange seals to ensure good sealing. These faces should be made good if necessary.

**4.7.4** If the appliance is to be fitted against a wall with combustible cladding, the cladding must be removed from the area covered by the fascia. The cladding must also not touch the fascia (See figure 1). We suggest that the actual fascia is used as a template to mark the area for combustible cladding removal and that this area is increased by at least 2mm all round.

**4.7.5** If the fireplace opening is greater than the acceptable dimensions given in this guide, do not use the back of a fire surround or marble to reduce the opening. This may cause cracking of the surround back or marble.

## 4.8 The hearth.

The appliance must be mounted behind a non-combustible hearth unless the conditions of section 4.10.1.1 are met (N.B. conglomerate marble hearths are considered as non-combustible). The appliance can be fitted to a purpose made proprietary class "O"-150°C surround. The hearth material must be at least 12mm thick. The periphery of the hearth (or fender) should be at least 50mm above floor level to discourage the placing of carpets or rugs over it.

The appliance must not stand on combustible materials or carpets.

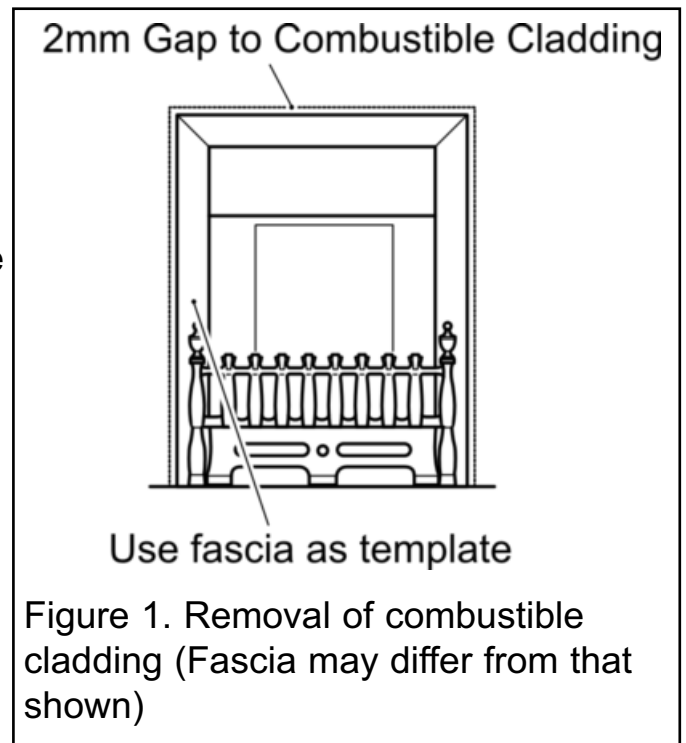

# INSTALLER GUIDE

## 4.9 Fireplace clearances.

**4.9.1** The minimum height from the base of the fireplace opening to the underside of any shelf made from wood or other combustible materials is detailed below.

- For a shelf up to 150mm deep: Minimum height = 750mm.
- For a shelf deeper than 150mm: 750mm + 12.5mm for every 25mm depth over 150mm (See figure 2).

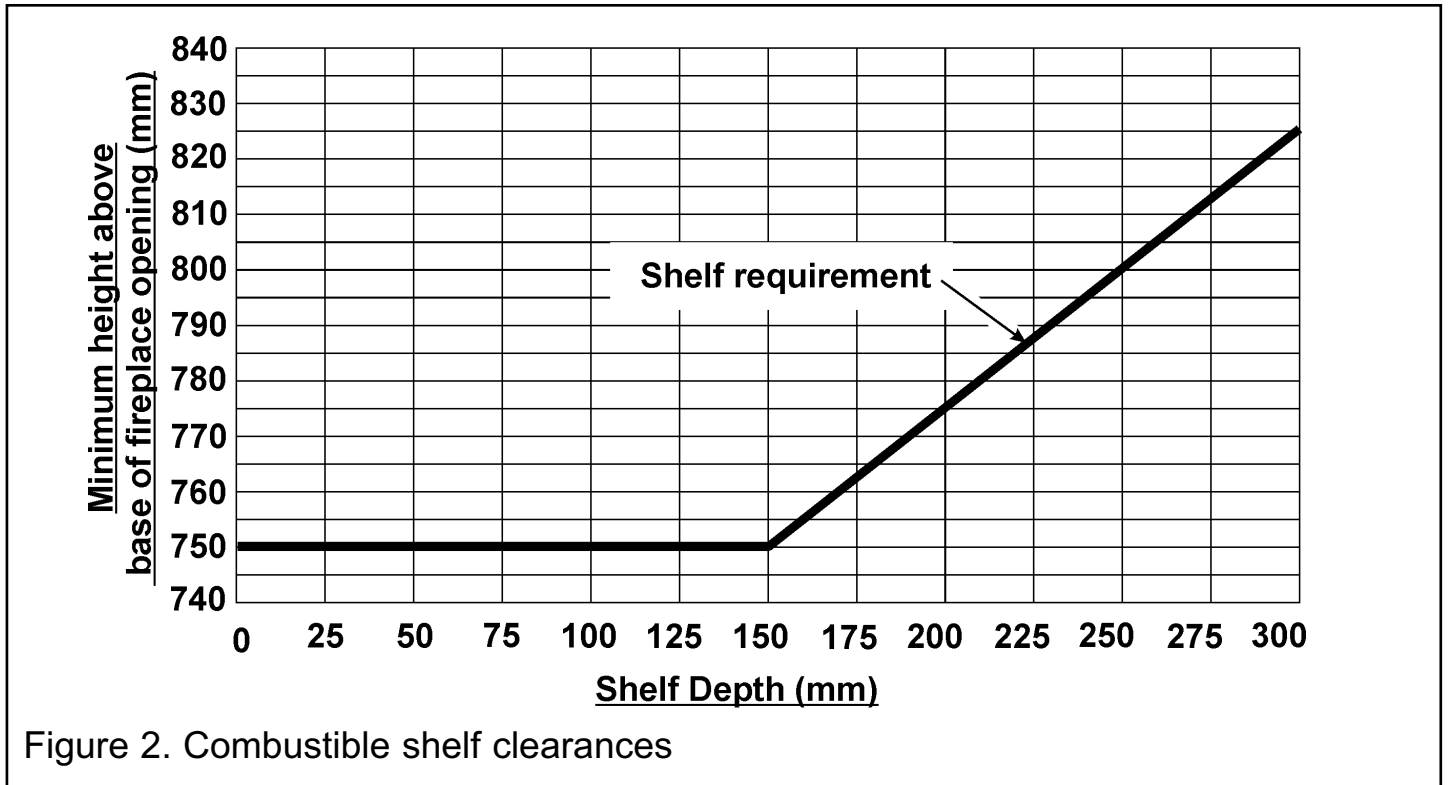

**4.9.2** The minimum allowable distance from the outside of the fascia to a corner wall having combustible material or any other combustible surface which projects beyond the front of the appliance is shown in figure 3. For access purposes the recommended clearances to non combustible surfaces are shown in figure 3.

# INSTALLER GUIDE

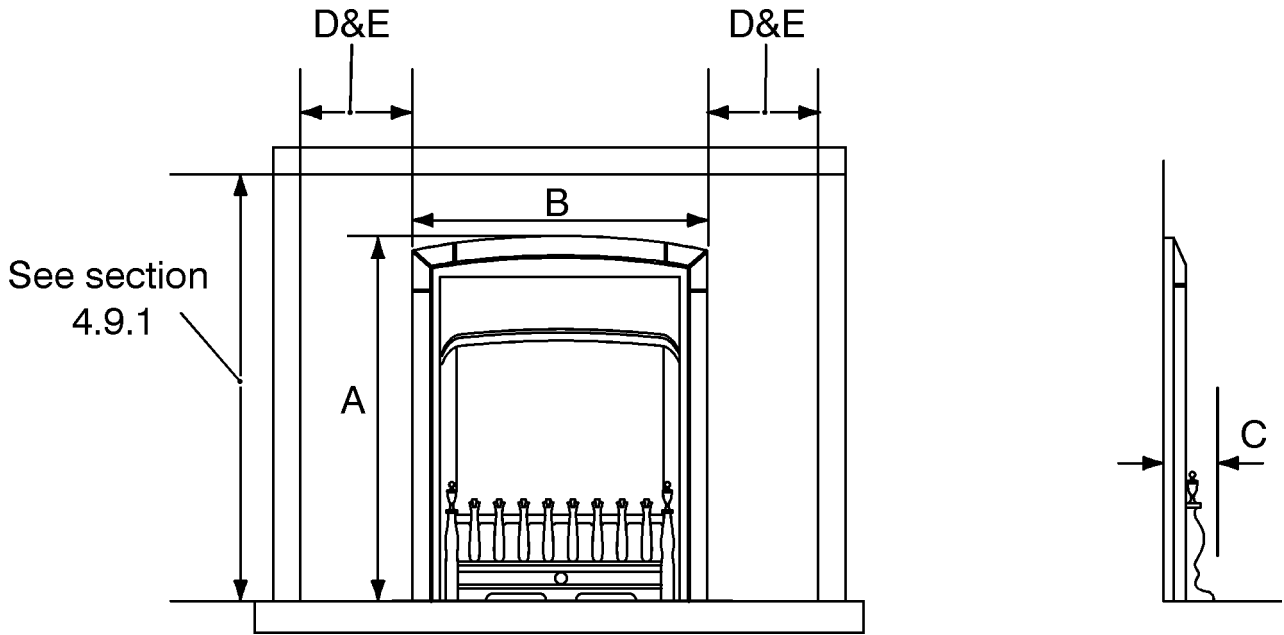

Model	Key				
	A	B	C	D	E
	Height (mm)	Width (mm)	Depth into room (mm)	Minimum mandatory clearance to <b>combustible</b> surfaces projecting beyond the front of appliance (mm).	<b>Recommended</b> clearance to <b>non-combustible</b> surfaces for access purposes (mm).
Blenheim	588	450	85	100	10
Seattle	588	450	63	100	10
Siva	590	455	80	100	10
Whitsbury	588	450	73	100	10

Figure 3. Appliance dimensions and clearances (Fascia may differ from that shown)  
 (The appliance dimensions 'A', 'B' & 'C' shown in the table are subject to manufacturing tolerance)

# INSTALLER GUIDE

## 4.10 Installation options.

In the United Kingdom, as supplied, the appliance can be installed in the following situations: -

### 4.10.1 Conventional fireplace and hearth.

To a fireplace complete with hearth as shown in figure 4. Chair brick removal may not be required providing at least 50mm clearance is available from the flue outlet to any fireplace component. The appliance is designed to cater for low lintel installations (min height 505mm) providing a minimum distance of 25mm is maintained between the lintel and the front face of the fireplace (i.e. 25mm rebated fire surround).

#### 4.10.1.1 'Hole-in-the-wall' Installations.

– It is recommended that a hearth should be installed as in section 4.8 (See figure 4).  
– If a reduced depth hearth is fitted, the fire must be installed so that the distance from the base of the fireplace opening in the wall to the finished floor level is at least 72mm. Where there is no floor covering or carpet and the floor is of a type that is likely to be covered in such a way then the distance from the base of the fireplace opening in the wall to the finished floor level should be increased to at least 147mm.

! If the lower part of the fascia (the firefront) is free standing, the recommended reduced hearth depth is 110mm. This is necessary to support the firefront (See figure 3 for appliance dimensions).

– To protect from the risk of burns and ignition of clothing a tactile separator shall be used. The hearth detailed in section 4.8 meets the requirements for a tactile separator. If this is not used then a 625mm long fender, kerb, horizontal bar, or other barrier, being fixed not less than 50mm above floor level and positioned 300mm in front of the fixing plane of the fire will meet the requirement.

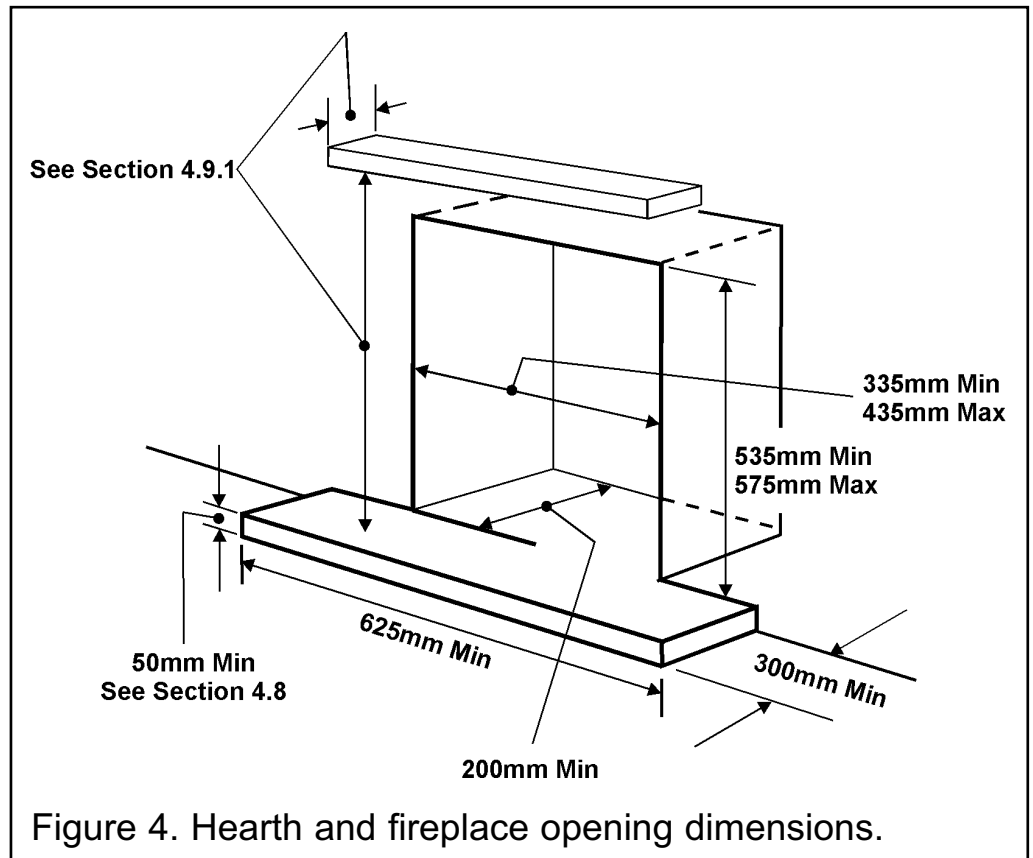

# INSTALLER GUIDE

## 4.10.2 Metal flue box and hearth.

The appliance can be installed to a fireplace incorporating a metal flue box complying with the constructional requirements of the current edition of BS 715 and with a flue conforming to BS EN 1856 part 1. The dimensions of the flue box must conform to those shown in figure 5.

The top surface of the metal flue box must be covered with a 50mm layer of mineral wool or equivalent insulation (See figure 5).

**Important Note:** Where the flue box has a base sheet that is single wall (i.e. a single metal sheet) the flue box must be mounted on a non-combustible hearth. The hearth material must be at least 12mm thick.

## 4.10.3 Precast concrete or clay flue block system and hearth.

The appliance can be installed to a precast concrete or clay flue block system conforming to BS1289 or BS EN 1858 with dimensions as in figure 6.

BS 1289 part 1 recommends there should be an air space or insulation between the flue blocks and the plaster because heat transfer may cause cracking on directly plastered flues. However, generally this appliance is suitable for installations under all circumstances unless there is a history of cracking problems.

Remember that faults such as cracking may be caused by poorly built and restrictive flues, e.g. mortar extrusions, too many bends, flue heights below three metres, restrictive terminations etc.

The appliance is suitable for installations conforming to older versions of BS1289 as well as the

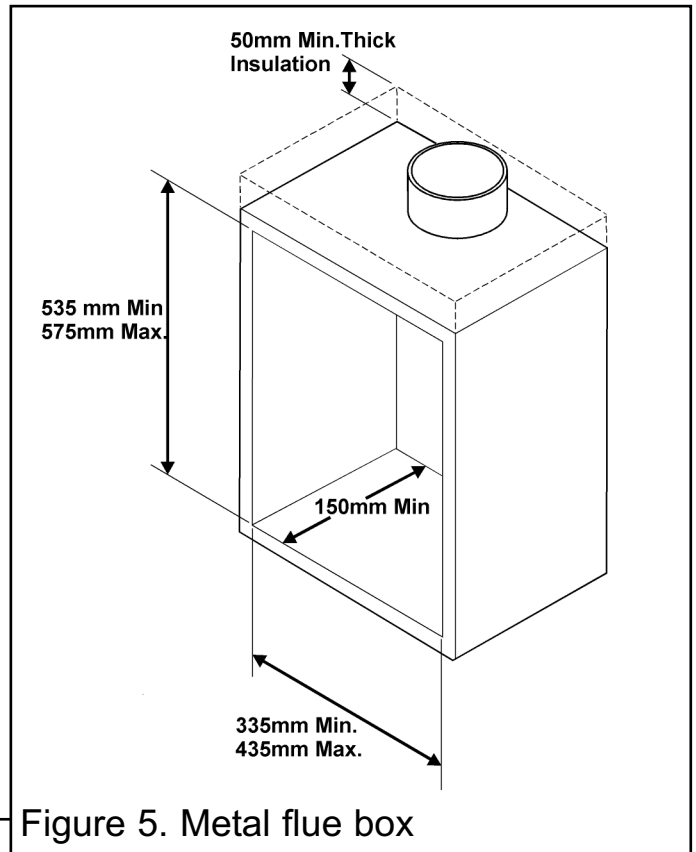

Figure 5. Metal flue box

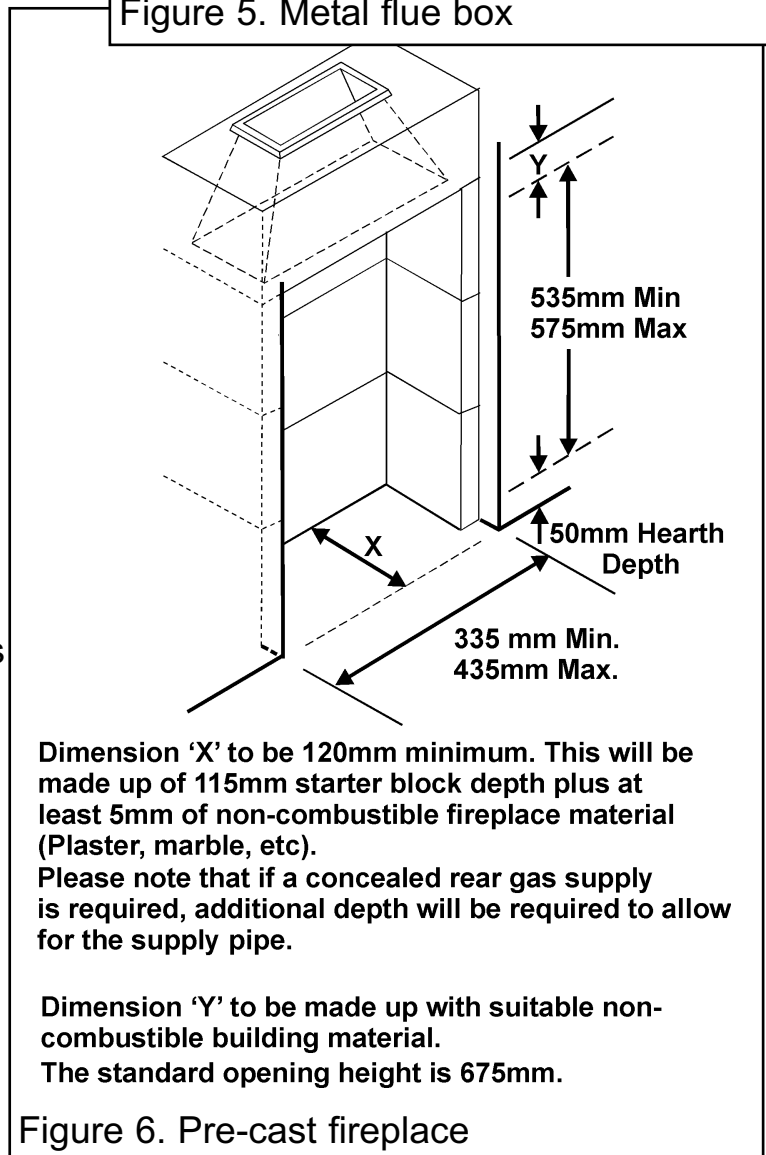

Figure 6. Pre-cast fireplace



# INSTALLER GUIDE

current edition. The flue blocks must have a minimum (Depth from the front of the fireplace opening) width not less than 63mm and a cross-sectional area not less than 13,000mm<sup>2</sup>. Older editions of BS1289 required a cross-sectional area of 13,000mm<sup>2</sup>. The current revision of the standard requires 16,500mm<sup>2</sup>. This appliance is suitable in both cases. The total depth of the opening measured from the finished front of the fireplace (Including plaster, surround etc.) must be **not less than 120mm** (See figure 6).

## 4.11 Flues.

1. Suitable flues and minimum flue sizes are as follows:

*It should be noted that, as with many appliances, sharp bends or horizontal runs in metal flues at the top of the system can be a cause of problems in these types of installation.*

- 225mm x 225mm conventional brick flue.
- Single wall, twin wall or flexible flue liner with a minimum diameter of 125mm. The materials to be used are stainless steel or aluminium as specified in BS EN 1856 Part 1. The liner must be sealed to the surrounding area above the fireplace opening and to the top of the chimney. An approved terminal must be fitted.
- 175mm diameter lined brick or stone flue.
- 200mm diameter factory made insulated flue manufactured to BS4543 Part 2.
- 175mm diameter flue pipe. See BS6461 Part 1 for suitable materials.
- A properly constructed precast concrete or clay flue system conforming to BS1289 or BS EN 1858. This system is only suitable if the conditions stated in section 4.10.3 are met.

2. The flue must conform to BS 5440: Part 1 in design and installation.

The flue, measured from the bottom of the fireplace opening to the bottom of the terminal, shall be not less than 3m in actual vertical height. When calculated in accordance with BS 5440: Part 1 Annex A, the minimum **equivalent** height of the flue shall be 2.0m of 125mm dia. flue pipe.

3. The flue must not be used for any other appliance or application.

4. Proprietary terminals must comply with BS 715 or BS 1289. Any terminal or termination must be positioned in accordance with BS 5440 Part 1 to ensure that the products of combustion can be safely dispersed into the outside atmosphere. Where the appliance is connected to an unlined brick chimney it is generally unnecessary for the chimney pot to be replaced or for a terminal to be fitted unless the flue has a diameter smaller than 170mm.

5. The flue must be completely sealed so that combustion products do not come into contact with combustible materials outside the chimney.

# INSTALLER GUIDE

## 4.12 Propane gas fires.

Propane gas appliances must not be installed in a room, which is built entirely below ground level (See BS 5871 Pt2).

## 5. PACK CONTENTS

Items below with a letter reference are supplied on a film wrapped card.

Remove all the items carefully to prevent damage. Take special care when handling the ceramic components. Some items may be contained in the packaging fittings - Examine the packaging carefully before discarding. Check that all the items are present and undamaged.

- 1 Loose parts pack including: -
- 4 'A' screws (No.8 x 6)
- 6 'B' screws (No. 8 x 10)
- 2 'C' screws (M4 x 10)
- 2 'D' screws (M5 x 10)
- 2 'F' Cable adjusters
- 1 'G' Inlet 'T' connector / elbow including pressure test point, nut and olive.
- 1 'H' Grommet for rear of hotbox.
- 4 'I' Wall plugs
- 4 'J' Screw eyes.
- 1 Hotbox and burner assembly
- 1 Burner tray trim
- 1 Length of self-adhesive foam seal
- 2 Fire retaining cables
- 1 Flue restrictor
- 1 Strip of floor sealing tape
- 1 Ceramic fuel effect
- 1 Fascia / Fascia & firefront
- 1 Literature pack.

# INSTALLER GUIDE

Hot box and burner assembly (1 off)

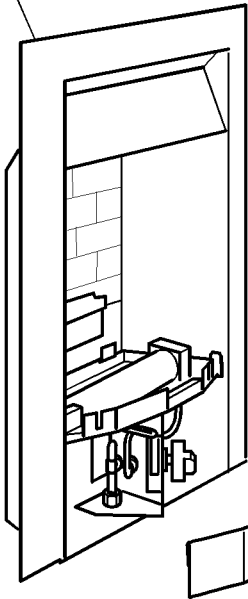

Flue restrictor (1 off)

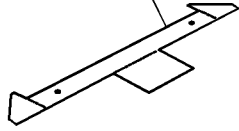

'A' No. 8 x 6 screw (4 off)



'B' No.8 x 10 screw (6 off)

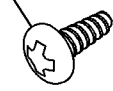

'C' M4 x 10 screw (2 off)

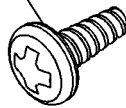

'D' M5 x 10 screw (2 off)

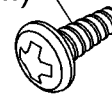

Burner tray trim (1 off)

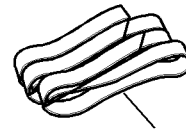
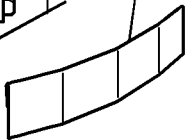

Self adhesive foam seal (1 off)

'J' Screw eyes (4 off)



Fire retaining cable (2 off)

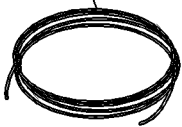

Floor sealing tape (1 off)

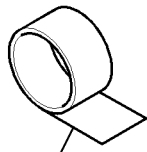

'I' Wall plugs (4 off)

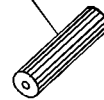

'F' Cable adjusters (2 off)

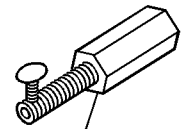

'G' Inlet 'T' connector with nut and olive (1 off)

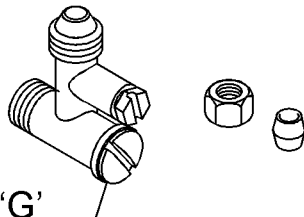

'H' Rubber grommet (1 off)

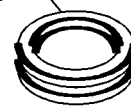

Figure 7. Pack contents (Not all of the components listed may be required)

# INSTALLER GUIDE

Coal fuel effect  
for use with:  
Whitsbury



Front coal  
base

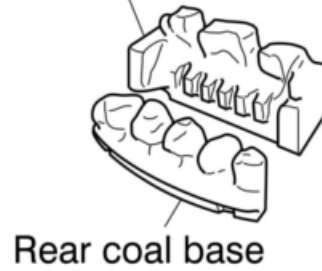

Coal fuel effect  
for use with:  
Blenheim



Pebble fuel effect  
for use with:  
Siva  
& Seattle

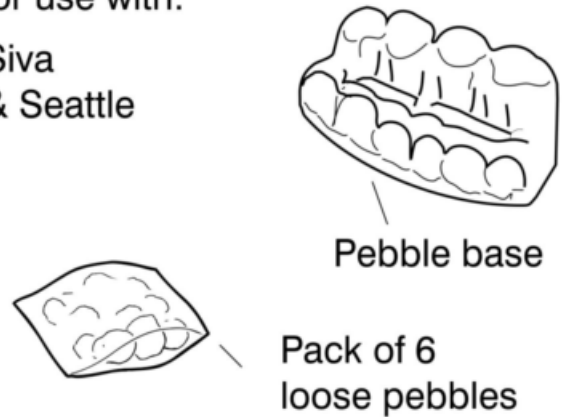

Siva fret

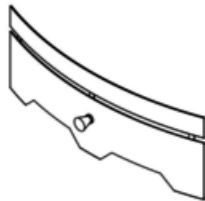

Seattle fret

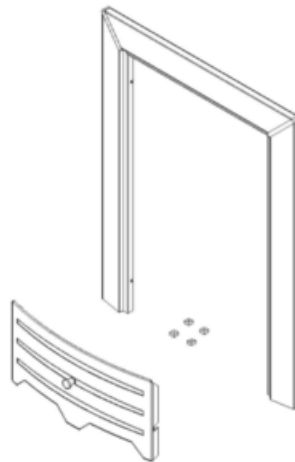

Magnetic fascia trim.  
Used with Siva fret  
only.

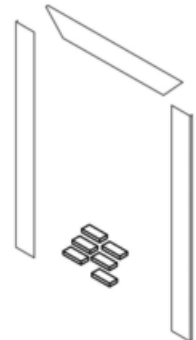

Magnetic fascia trim.  
Used on:  
Blenheim, Seattle &  
Whitsbury models.

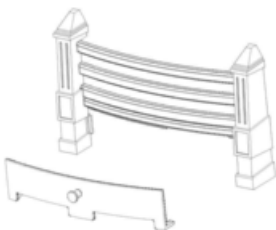

Whitsbury fret

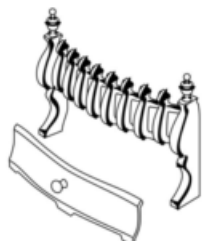

Blenheim fret

Figure 7. Pack contents continued.

### 6.1 Soundness for appliance attachment.

Two primary methods of retaining the appliance are provided: -

- 1) By fixing to the fireplace front surround.
- 2) Using concealed tension cables fixed to the rear of the fireplace opening.

The methods are detailed in section 10 of this manual. Before selecting the retention method, consult with the customer. Method 2 is provided for instances where drilling holes in the front surface of the fireplace surround is unacceptable to the customer or otherwise impractical. *N.B. It is unwise to attempt to drill into marble without the proper tools and equipment.*

If method 1 is chosen, make sure that the front surround area is sound enough to take the wall plugs and screws. If necessary, make sound with a suitable cement. If method 2 is chosen, make sure that the areas at the back and towards the centre of the fireplace floor are sound enough to take the screw eyes. If these areas have deteriorated due to prolonged use, they should be made sound with a suitable cement.

### 6.2 Fireplace flue pull.

Close all doors and windows in the room in which the appliance is to be installed.

After confirming with a match that smoke is drawn into the flue, light a 13 gram smoke pellet and check that there is a definite flow through the flue. Verify outside that the smoke exits from one terminal only and that the termination is suitable.

Observe where possible, upstairs rooms and loft spaces for signs of escaping smoke indicating a defective flue. If there is not a definite flow warm the flue for a few minutes and repeat the smoke pellet test. If there is still no definite flow the flue may need remedial work – **Do not fit the appliance until there is a definite flow through the flue.**

# INSTALLER GUIDE

## 7. IGNITION CHECK

Before attempting to install, it is worth checking that the ignition system performs satisfactorily.

- Set the control knob to the 'OFF' position.
- Depress the control knob and rotate it anticlockwise to the 'pilot ignition' position. A 'click' will be heard as the integral piezo operates. A spark should be seen between the electrode and pilot tip. If there is no spark check the following: -

- Ensure that the electrode lead is connected to the terminal at the base of the electrode.

! If the above is correct, check for damage to the electrode lead.

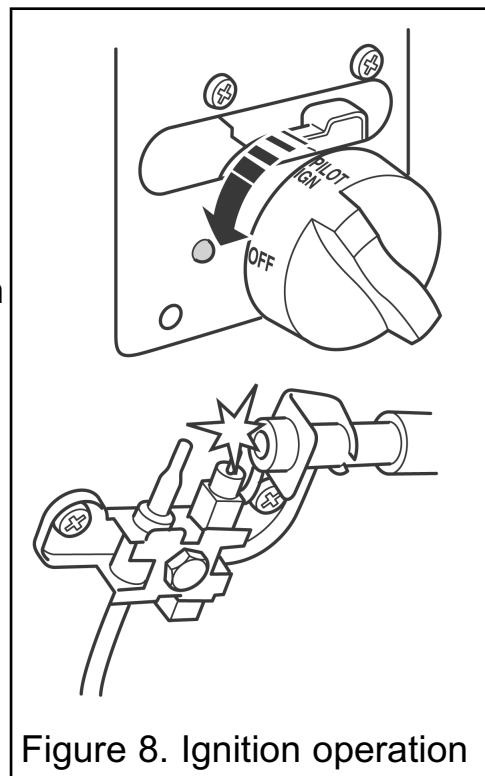

Figure 8. Ignition operation

## 8. GAS SUPPLY CONNECTION

A nut and olive are provided for an 8mm pipe inlet connection to the inlet elbow at the bottom front of the appliance. The inlet elbow can be rotated to allow a connection from any direction. The inlet elbow includes a valve for isolating the gas supply and a pressure test point.

The supply pipe must be rigid material. Flexible pipe must not be used.

### **Concealed supply pipe connection.**

If a concealed connection from inside the fireplace is required then, **before the appliance is fitted into the fireplace** it will be necessary to extend the supply line so that it will project through the hole in the back of the hotbox and run to the inlet elbow at the front. The pipe run from the supply line up to the rear opening in the hotbox must be kept away from the area which will be taken by the hotbox when it is installed. Note that the centre of the appliance inlet elbow is 25mm above the fireplace floor. The inlet elbow should be fitted to the supply pipe at this stage.

# INSTALLER GUIDE

## 9. PREPARING APPLIANCE FOR INSTALLATION

### 9.1 Appliance preparation.

1. Remove any transit tape and packing and inspect for any evidence of mishandling which might affect the performance of the fire. Each unit is flame tested before it leaves the factory and as a result there may be slight discolouration around the burner ports.

2. Detach the burner unit from the hotbox by removing two screws (See figure 9). Lift the burner unit clear.

3. It is important that the grommet 'H' supplied in the loose parts pack is fitted to the hole in the rear of the hotbox.

### 9.2 Fitting the foam seal (All models).

There is a length of self adhesive foam seal supplied with the fire. This will need to be fitted to the outer rear edges of the side and top flanges of the hotbox. Cut the foam seal to the required length. Be careful not to stretch the seal when measuring. Remove the protective backing from the foam seal and fit this to the rear of the hotbox flange (See figure 10).

### 9.3 The flue restrictor.

This appliance is supplied with a flue restrictor for use where the flue draught is excessive. **The restrictor must not be fitted where a precast flue or a 125mm flue liner is used.** For flue liners greater than 125mm and all other installations the restrictor should be fitted. There may however, be certain exceptional circumstances where fitting the restrictor causes the fire to fail the spillage test. In such cases the restrictor will have to be removed. After removal conduct the spillage check again.

The restrictor is packed flat with the appliance and will require bending prior to fixing. Bend the restrictor as shown in figure 11.

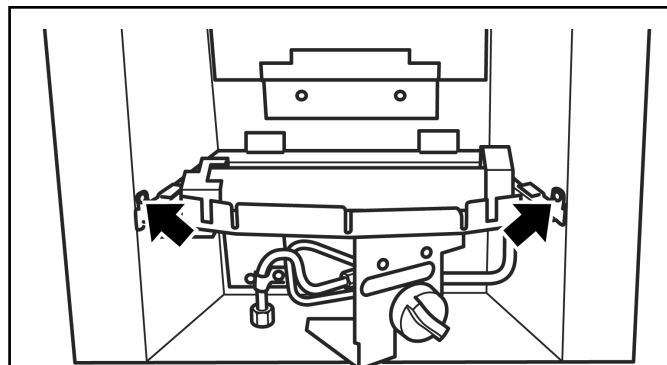

Figure 9. Burner attachment points

The Foam Seal should touch at this point  
Ensure that there is no gap between the seals

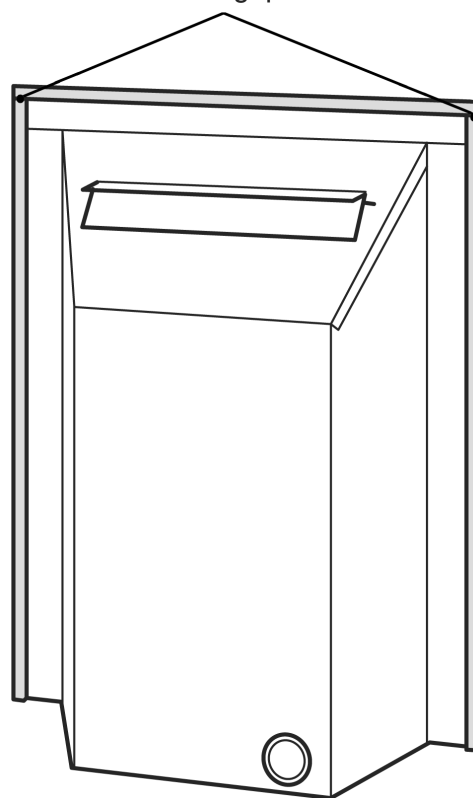

Figure 10. Fitting the foam seal

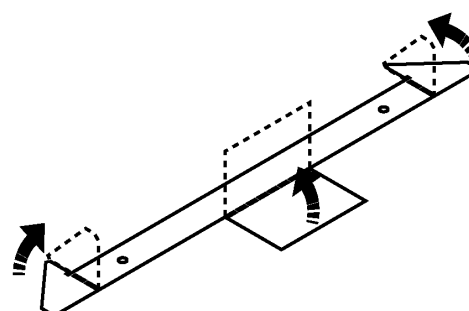

Figure 11. Bending the restrictor

# INSTALLER GUIDE

Fit the restrictor as shown in figure 12 using the two 'B' screws provided.

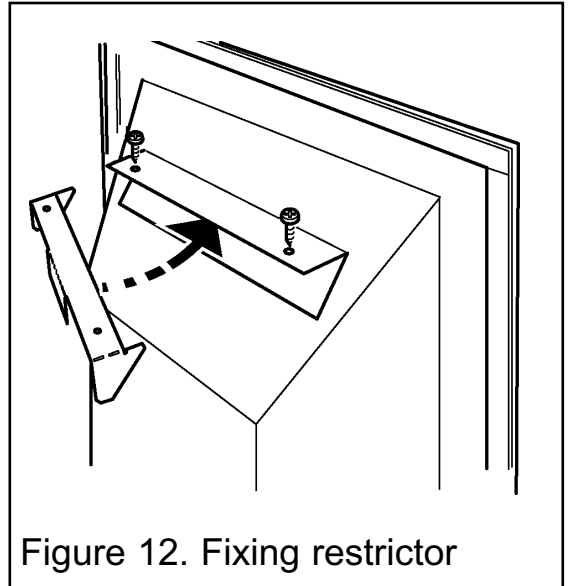

Figure 12. Fixing restrictor

## 10. HOTBOX INSTALLATION

### 10.1 Method 1- Front fixing to fireplace surround.

1. Make sure that the fireplace front surround area is sound enough to take the wall plugs and screws. If necessary, make sound with suitable cement.

2. Place the hotbox centrally in the fireplace in the position in which it is to be permanently installed. If a concealed connection is being used, insert the hotbox into the fireplace feeding the supply pipe through the pierced hole in the rear seal.

3. Mark the fireplace front surround through the four fixing holes in the side flanges of the hotbox (See figure 13).

4. Remove the hotbox. Drill four holes in the fireplace front surround at the marked positions using a suitably sized masonry drill bit for the wall plugs supplied.

5. Insert a wall plug 'I' into each hole.

6. Place the hotbox back in position in the fireplace.

7. Fit a suitable screw (Not supplied) through each hole in the hotbox flanges and tighten to seal the box to the fireplace surround. We recommend the use of a screw with 1 1/2 inches (38mm) length.

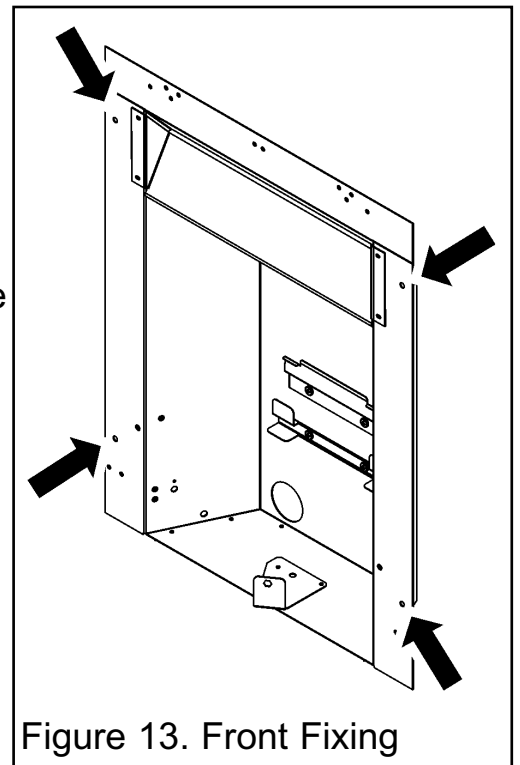

Figure 13. Front Fixing



# INSTALLER GUIDE

## 10.2 Cable retention.

1. Make sure that the relevant areas at the fireplace back are sound enough to take the screw eyes. If these areas have deteriorated due to prolonged use they should be made sound with a suitable cement.

2. Drill four holes in the rear wall of the fireplace for the wall plugs. The holes should be drilled within the range of positions shown in figure 14 using a suitably sized masonry drill bit for the wall plugs supplied. The holes should be equidistant each side of the centre line of the fireplace to ensure that the appliance finishes centrally in the opening when tension is applied to the cables.

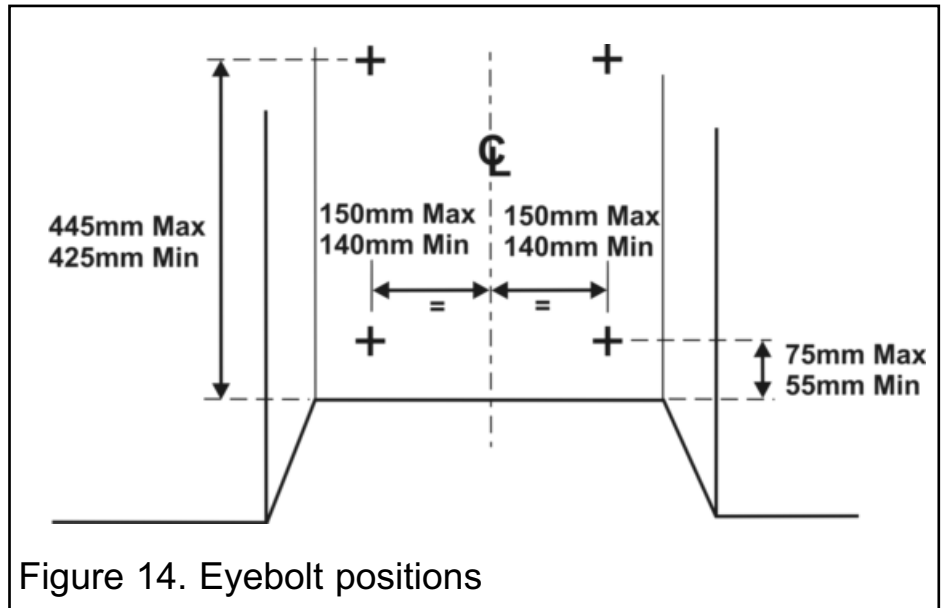

Figure 14. Eyebolt positions

3. Insert a wall plug 'I' into each hole. Use the wall plugs supplied with this appliance - **Never use plastic plugs instead of the wall plugs supplied.** Screw the screw eyes 'J' into the plugs. Make sure that the screw eyes are secure.

4. Place the hotbox unit close to the fireplace but allow sufficient access into the fireplace opening so that the cables can be threaded through the screw eyes and returned through the back of the hotbox. If a concealed connection is being used, insert the hotbox into the fireplace feeding the supply pipe through the pierced hole in the rear grommet.

5. The rear of the hotbox has a slot and hole each side of the outlet opening. Assemble one end of the cable to the top of the fire by passing it through the small round hole and locking by positioning the cable in the adjacent slot (See figure 15). Give the cables a pull so that they grip.

6. Thread the cables through the screw eyes. Return the cables through the holes near the bottom of the hotbox side panels (See figure 16).

7. Place the hotbox fully back into the fireplace opening so that it is sealed against the fireplace front surround.

8. Fit a cable adjuster 'F' over the bottom end of each cable.

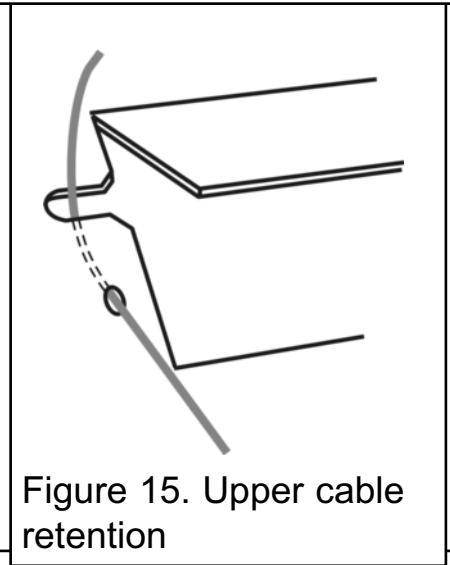

Figure 15. Upper cable retention

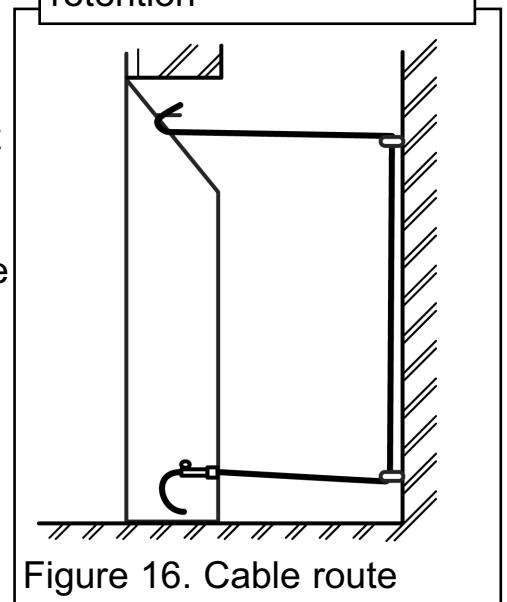

Figure 16. Cable route

# INSTALLER GUIDE

**9.** Pull each cable taut. Push the cable adjusters hard up against the back panel. Tighten the screws in the adjusters so that they clamp the cables in position. Apply tension to the cables by turning the hexagonal adjusters by hand (See figure 17).

**10.** Inspect the installation of the hotbox against the fireplace surround. If the hotbox is aligned squarely and the sealing is satisfactory, fully tighten the cable adjusters.

**11.** If the hotbox is not correctly aligned, release the tension on the cables by slackening the screws and turning the hexagonal adjusters fully anticlockwise. The hotbox should then automatically realign itself. Pull each cable taut again and push the cable adjusters back against the back panel. Again, tighten the screws in the adjusters and apply tension to the cables by turning the hexagonal adjusters clockwise as far as possible.

**12.** Do not cut off any excess cable, instead coil up the cable so that they are available to allow easy removal and refitting of the appliance during subsequent service calls.

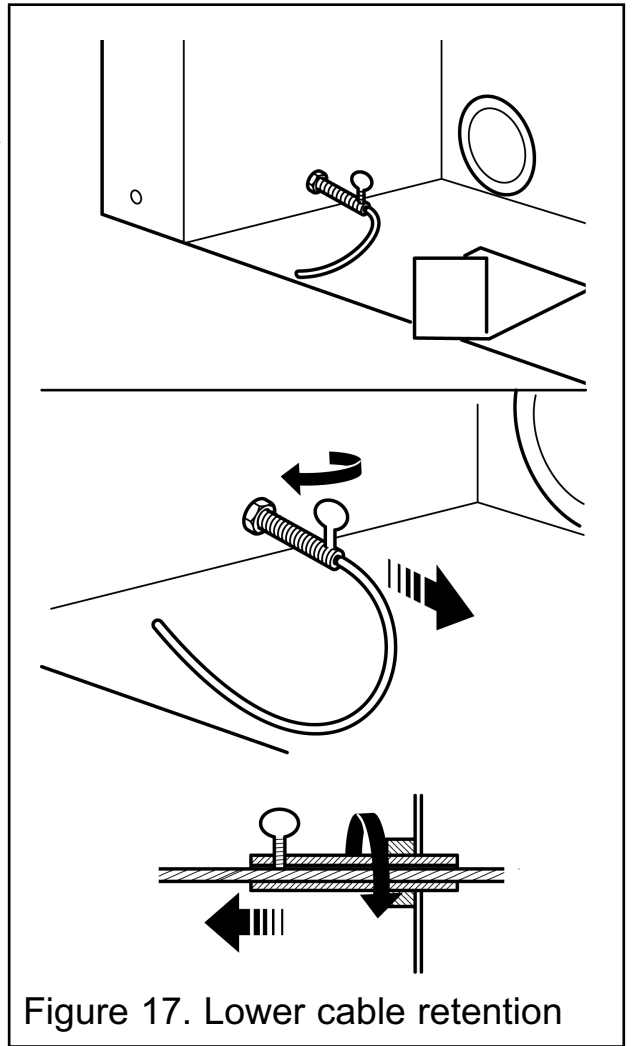

## 10.3 Floor sealing.

Using the floor sealing tape supplied, seal the bottom of the hotbox to the fireplace and hearth floor. Run the tape over the centre bracket (See figure 18).

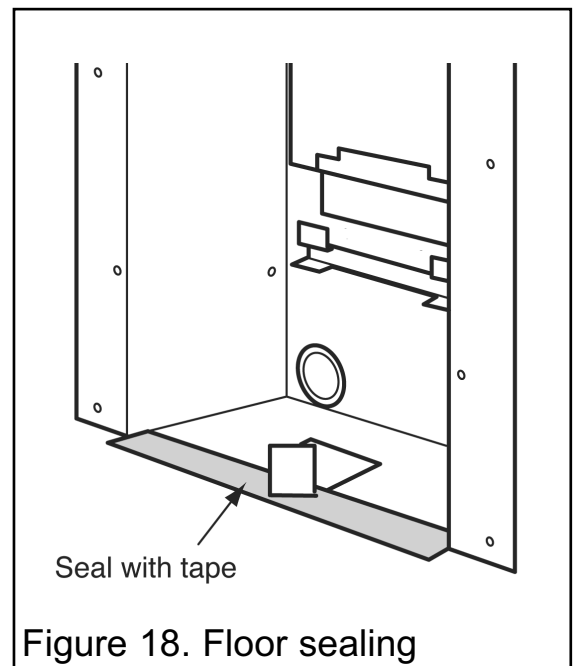

# INSTALLER GUIDE

## 11. BURNER INSTALLATION

### 11.1 Burner and supply pipe installation.

1. Refit the burner unit to the hotbox using the two screws removed previously. The burner securing points should be on the inside of the hotbox as shown in figure 19.

2. Connect the supply line to the appliance.

3. If closed, open the isolating valve at the inlet elbow.

4. Turn on the gas supply and pressure check the installation pipework for gas soundness. In the United Kingdom check in accordance with

the current edition of BS 6891. In the Republic of Ireland refer to the current edition of I.S. 813 "Domestic gas installations".

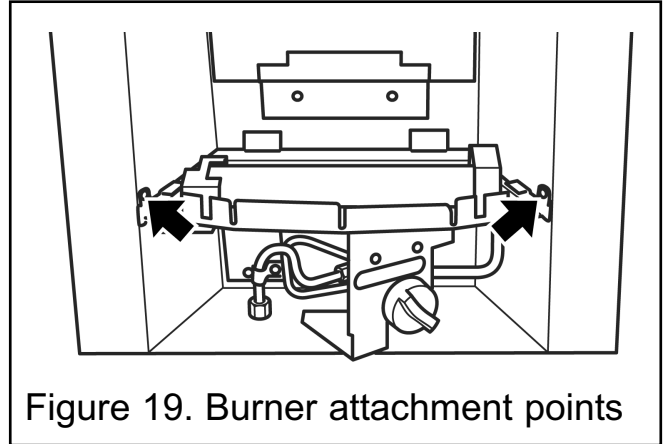

Figure 19. Burner attachment points

### 11.2 Lighting the burner.

1. Depress the control knob and rotate it slowly anticlockwise to the 'PILOT / IGN' position. A 'click' will be heard as the integral piezo operates. A spark should be seen between the electrode and pilot tip.

2. Turn the control knob clockwise to the 'OFF' position. Repeat this operation until a flame appears at the pilot. There may be a delay before the pilot lights due to air being purged from the system. When a flame appears at the pilot keep the control knob depressed and hold the pilot ignition position for ten seconds. When the control knob is released the pilot flame should remain lit.

### 11.3 Operating the burner.

1. When the pilot burner is operating properly, gradually turn the control knob anticlockwise to 'HIGH' (Depress the knob slightly to get past the 'PILOT / IGN' position). The main burner should now light. Depress the control knob slightly to release from the 'HIGH' position and turn back (clockwise) to 'LOW'. While turning, the burner flames should gradually become lower but remain alight. Depress the control knob slightly to release from the 'LOW' position and turn back (clockwise) to the 'PILOT / IGN' position. The main burner should extinguish but the pilot should remain alight. Depress the control knob slightly and turn back (clockwise) to turn OFF.

This will extinguish the pilot.

If the above checks are satisfactory, continue with the installation. If not, check the control and ignition circuitry and components.

# INSTALLER GUIDE

## 11.4 Inlet pressure check.

The appliance is pre-set to give the correct heat input at the inlet pressure shown in section 3 of this manual. No adjustment is necessary.

1. Check the inlet pressure by fitting a pressure gauge at the test point. The test point is on the inlet elbow (See figure 20). Check the pressure with the appliance alight and set at maximum output.
2. After checking, turn off the appliance. Remove the pressure gauge and replace the test point sealing screw.
3. Relight the appliance. Turn to the maximum output position and test around the sealing screw for gas soundness with a suitable leak detection fluid.

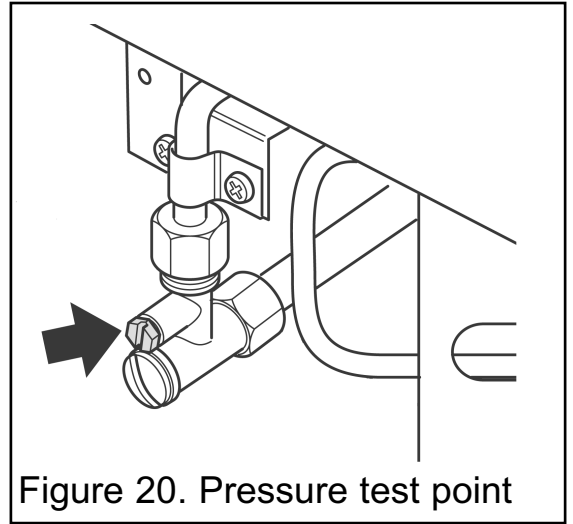

Figure 20. Pressure test point

## 11.5 Fitting the burner tray trim.

1. Fit the burner tray trim over the front rim of the burner tray. Push the trim fully down (See figure 21).

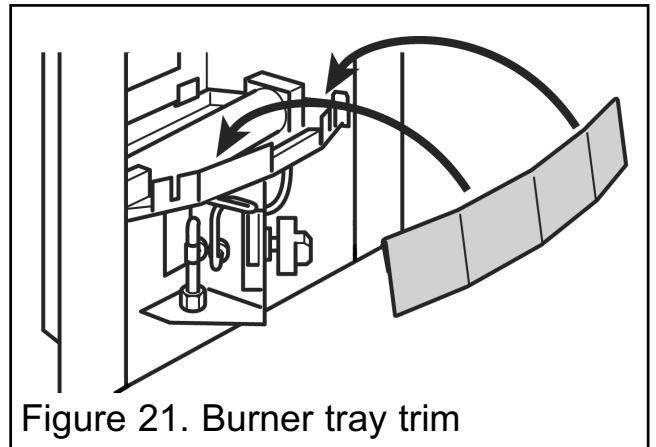

Figure 21. Burner tray trim

## 12. FULL OPERATING CHECKS & BENCHMARKING SCHEME

### 12.1 Check the control settings.

With the ceramic fuel effect in position the control operation must now be fully rechecked. Make sure that the isolating valve at the inlet elbow is open.

- When first turned on from cold, the flames will appear predominantly blue.
- When operating the fire for the first time, some vapours may be given off which could set off smoke alarms in the vicinity. These vapours are quite normal with new appliances. They are totally harmless and will disappear after a few hours use.

#### 12.1.1 Lighting the burner.

1. If closed, open the isolating valve at the inlet elbow.
2. Depress the control knob and rotate it slowly anticlockwise to the pilot ignition position. A 'click' will be heard as the integral piezo operates. A spark should be seen between the electrode and pilot tip.
3. Turn the control knob clockwise to the 'OFF' position. Repeat this operation until a flame appears at the pilot. There may be a delay before the pilot lights due to air

# INSTALLER GUIDE

being purged from the system. When a flame appears at the pilot keep the control knob depressed and hold the pilot ignition position for five seconds. When the control knob is released the pilot flame should remain lit.

## **12.1.2 Operating the burner.**

1. When the pilot burner is operating properly, gradually turn the control knob anti-clockwise to 'HIGH' (Depress the knob slightly to get past the 'PILOT / IGN' position). The main burner should now light. Depress the control knob slightly to release from the 'HIGH' position and turn back (clockwise) to 'LOW'. While turning, the burner flames should gradually become lower but remain alight. Depress the control knob slightly to release from the 'LOW' position and turn back (clockwise) to the 'PILOT / IGN' position.

The main burner should extinguish but the pilot should remain alight. Depress the control knob slightly and turn back (clockwise) to turn off. This will extinguish the pilot.

If the above checks are satisfactory, continue with the installation. If not, check the control and ignition circuitry and components as described in the servicing section of this guide.

While cooling the ceramic fuel effect may make some crackling noises. This is quite normal.

## **12.1.3 The Benchmark Scheme**

GDC Group is a licensed member of the Benchmark Scheme which aims to improve the standards of installation and commissioning of domestic heating and hot water systems in the UK and to encourage regular servicing to optimise safety, efficiency and performance. Benchmark is managed and promoted by the Heating and Hotwater Industry Council.

It places responsibilities on both manufacturers and installers. The purpose is to ensure that customers are provided with the correct equipment for their needs, that it is installed, commissioned and serviced in accordance with the manufacturer's instructions by competent persons and that it meets the requirements of the appropriate Building Regulations.

The Benchmark Checklist (on the inside back pages of this guide) can be used to demonstrate compliance with Building Regulations and should be provided to the customer for future reference.

Installers are required to carry out installation, commissioning and servicing work in accordance with the Benchmark Code of Practice which is available from the Heating and Hotwater Industry Council who manage and promote the Scheme.

Visit [www.centralheating.co.uk](http://www.centralheating.co.uk) for more information.

At the time of commissioning, complete all relevant sections of the Benchmark Checklist located on the inside back pages of this document.

# INSTALLER GUIDE

## 13. FASCIA AND FIREFRONT INSTALLATION

### 13.1 Fitting a firefront that has not been supplied with the fire.

– A slotted firefront with a **minimum** free area as shown in figure 22 must always be used.

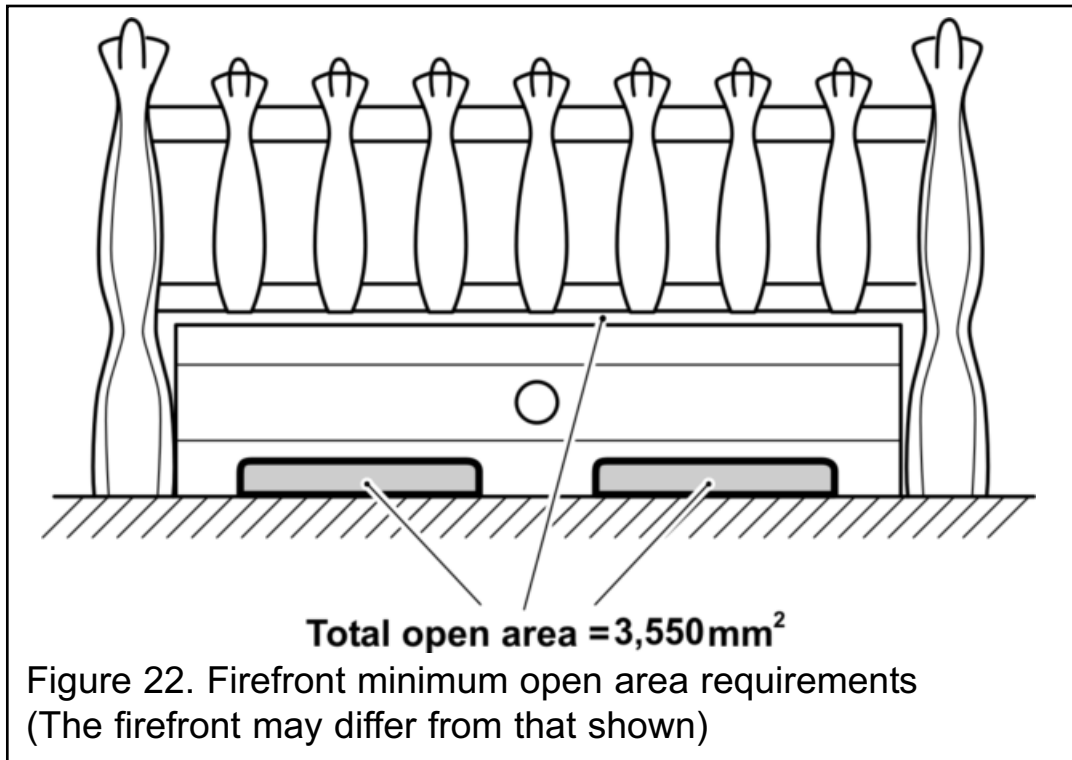

– For models supplied with a Valor Fires firefront, the open area may differ slightly from that stated in figure 22. In these cases the firefront will have been tested with the fire and found to be satisfactory for use with the fire.

### 13.2 Fitting the magnetic three piece fascia trim.

1. The fascia is supplied in three pieces. Carefully remove the three pieces from the packaging. Remove any protective film.
2. The magnets used to locate each trim should already be positioned on the rear of each trim. Each trim should have two magnets. If the magnets are not fitted then locate one magnet centrally at each end of the trims.
3. Locate the side trims as in figure 23.
4. Locate the top trim as in figure 23.
5. The Siva fascia trim is already assembled and can be located as in Figure 23 but all in one piece.

# INSTALLER GUIDE

## 13.3 Fitting the Blenheim firefront.

1. Place the firefront / casting on top of the hearth centrally between the fascia.
2. On models with a two piece firefront place the lower front cover casting / ash pan below the front casting.

## 13.4 Fitting the Seattle/Siva firefront.

1. Place the firefront on top of the hearth centrally between the fascia.
2. The Siva has two additional magnets supplied. These can if necessary be used to hold the firefront in place to the inside faces of the fascia. Place the two magnets at the rear either side of the firefront where the return bends are located. This will assist when fitting into the fascia.

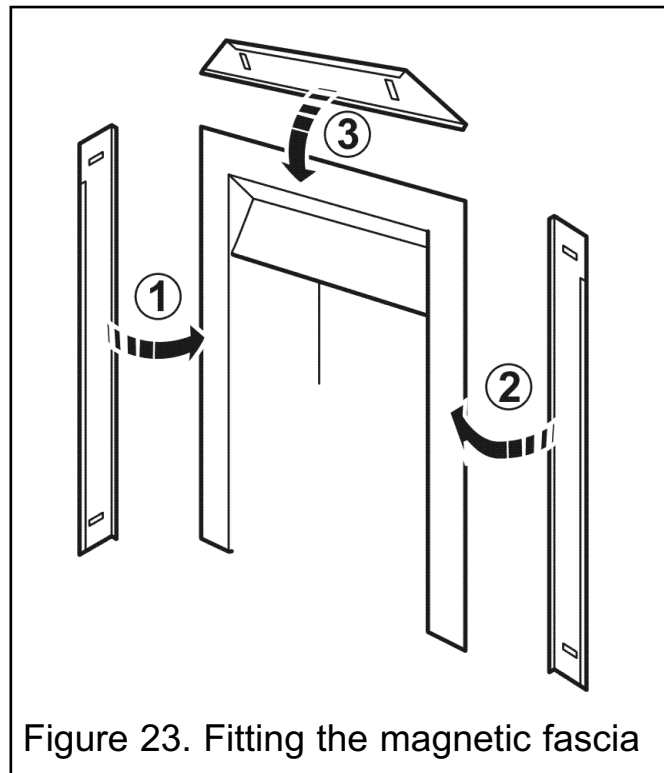

# INSTALLER GUIDE

## 14. SPILLAGE AND FLAME SUPERVISION CHECKS

### 14.1 Check for spillage.

**A spillage check must be made before leaving the installed appliance with the customer. Make this with all the ceramic fuel effect pieces and firefront casting / firefront in position.**

1. Close all doors and windows in the room containing the appliance.
2. Light the appliance and turn the control knob to "HIGH".
3. Leave the appliance on for five minutes.
4. Place the smoke match into the appliance canopy (See figure 27).
5. The installation is satisfactory if the smoke is drawn into the appliance. If the smoke is not drawn into the appliance, leave the appliance alight at the maximum setting for a further ten minutes and then repeat the test. If smoke is still not drawn into the appliance, inspect the sealing to the fireplace surround. If the sealing is satisfactory but the appliance is installed with the flue restrictor (See section 9.3), remove the restrictor, reseal the appliance and retest. If smoke is still not drawn into the appliance, **disconnect the appliance and seek expert advice.**

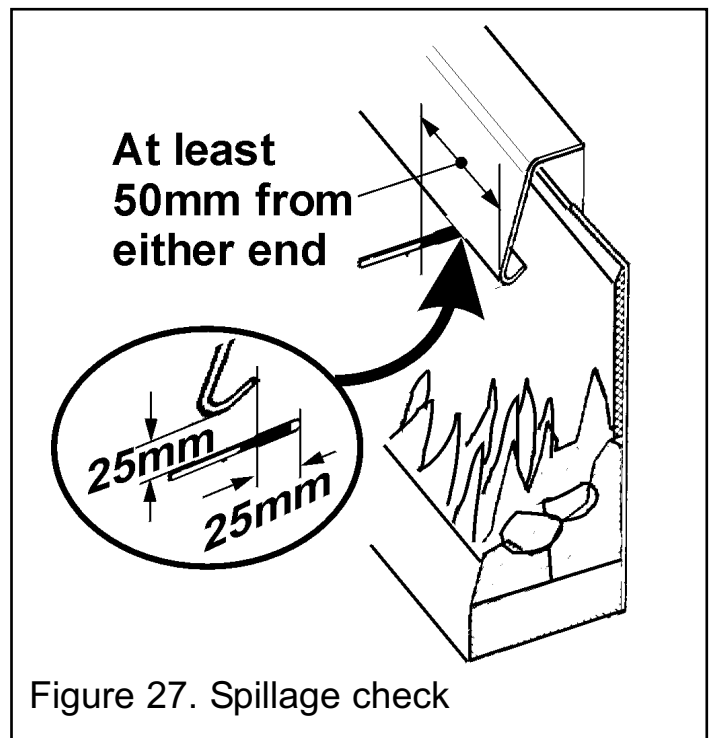

6. If the above test is satisfactory, open all internal connecting doors, hatches, etc., in the room. Keep all doors and windows that open to the outside of the building closed. Recheck for spillage as above. If an extractor fan is installed in the same room as the appliance or a connecting room, check that spillage does not occur with the fan operating and all doors and other openings between the fan and the appliance open. If the smoke is drawn into the appliance, continue with the installation. If the test is not satisfactory, **disconnect the appliance and advise the customer of the cause of failure.**

### 14.2 Flame supervision and spillage monitoring system.

The pilot unit incorporates a system that will automatically shut off the gas supply if the pilot flame goes out or if there is insufficient oxygen due to spillage or lack of ventilation.

Check that the system operates properly as follows;

- Light the appliance. Set at the "HIGH" position and leave for one minute.
- Turn back to "OFF" to extinguish the pilot. **Note the time when the pilot goes out.**



# INSTALLER GUIDE

Listen for a snap sound at the gas tap. **Note the time when the sound is heard.** This sound is caused by an electromagnetic valve shutting off the gas supply through the tap. The valve is located in the body of the tap. The valve should operate **within 60 seconds of the pilot going out.** If the valve does not operate within this time limit do not allow the appliance to be used until the fault has been corrected.

**This monitoring system must not be adjusted, bypassed or put out of operation.**

**This monitoring system, or any of its parts, must only be exchanged using Valor Fires authorised parts.**

## 15. FINAL REVIEW

**1. COMPLETE THE INFORMATION IN THE WARRANTY AND SERVICE SECTION OF THE OWNER GUIDE (See last pages of the OWNER guide).**

**2.** Visually inspect the appliance. Clean off any marks incurred during installation.

**3.** Advise the customer how to operate the fire.

**4.** Explain to the customer that the appliance has a flame failure and spillage monitoring system. Point out the explanation of this system shown in the owner guide. Advise that if the fire goes out for any reason, wait at least three minutes before relighting. Stress that if the monitoring system repeatedly shuts off the fire, the appliance should be switched off and a specialist should be consulted. Point out that the lighting instruction details are on a metal plate attached at the bottom of the appliance behind the firefront and by the control knob.

**5.** Advise that the fire may give off a slight odour while new. This is quite normal and it will disappear after a short period of use.

**6.** Advise that any cleaning must only be carried out when the fire is off and cold.

**7.** Advise the customer that they should read the Owner guide before operating the fire and always follow the advice in the section headed "Cleaning your fire".

**8.** Advise the customer that the appliance will operate to its maximum potential if the flue is primed during the first 20 – 30 minutes of use. To do this, simply turn the control to its highest setting. This will also burn off any carbon deposits that may have formed during previous use.

If using the appliance for long periods it is beneficial to change between settings. This will also help to remove any carbon deposits that may form during use.

**9.** Recommend that the appliance should be serviced and the chimney inspected by a competent person (In the UK a GAS SAFE REGISTER engineer, Outside of the UK a CORGI or GAS SAFE REGISTER engineer) at least annually.

If the appliance is in premises in the United Kingdom occupied by a tenant, point out that by law a landlord must have any gas appliance, flue and pipework which is situated in a tenant's premises checked for safety at least every 12 months.

# INSTALLER GUIDE

**10.** Advise the customer that the firefront, fascia, hotbox and ceramic pieces can be cleaned as described in the owner guide and that the loose ceramic fuel effect pieces must be replaced as described in the installer and owner guide supplied with them.

***Stress that no extra ceramic fuel effect pieces must be added over and above those supplied with the appliance and that any replacements must only be the authorised spares. Warn that ignoring this advice could cause incomplete clearance of the products of combustion with consequent health hazards.***

**11.** Inform the customer that the Serial number for the appliance is located on the metal plate attached at the bottom of the appliance behind the firefront and by the control knob.

**12.** Hand the literature pack with this guide to the customer.

## 16. SERVICING AND PARTS REPLACEMENT

- **Always turn off the gas supply and allow to cool completely before commencing any servicing (The appliance inlet “T” connector / elbow incorporates an isolating valve).**
- **It is recommended that, at least once a year, the appliance is disconnected and the fireplace opening checked and cleared of any debris.**
- **This product uses fuel effect pieces and a burner compartment rear wall containing Refractory Ceramic Fibres (RCF), which are man-made vitreous silicate fibres. Excessive exposure to these materials may cause irritation to eyes, skin and respiratory tract. Consequently, it is important to take care when handling these articles to ensure that the release of dust is kept to a minimum. To ensure that the release of fibres from these RCF articles is kept to a minimum, during installation and servicing we recommend that you use a HEPA filtered vacuum to remove any dust and soot accumulated in and around the fire before and after working on the fire. When replacing these articles we recommend that the replaced items are not broken up, but are sealed within a heavy duty polythene bag, clearly labelled as RCF waste. RCF waste is classed as a stable, non-reactive hazardous waste and may be disposed at a landfill licensed to accept such waste. Protective clothing is not required when handling these articles, but we recommend you follow the normal hygiene rules of not smoking, eating or drinking in the work area and always wash your hands before eating or drinking.**
- **This appliance does not contain any component manufactured from asbestos or asbestos related products.**
- **Check that the appliance is clean and that soot or debris is not blocking the gaps between the ceramic fuel effect pieces causing an imperfect flame.**
- **Check that soot or debris is not impairing the electrode spark or pilot burner.**
- **Check that soot or debris is not blocking any of the slots in the main burner.**

# INSTALLER GUIDE

- After servicing, make sure that the ceramic wall is replaced as described in this guide and the ceramic fuel effect pieces are replaced correctly as described in the installer and owner guide supplied with the ceramic fuel effect. The ceramic fuel effect guide may have been placed inside or attached to this guide.
- Always test for gas soundness and spillage after servicing the appliance.

## 16.1 Checking the aeration setting of the burner.

The aeration shutter is factory set and should not require adjustment. If the shutter is not as shown in figure 28 and requires adjustment, loosen the two aeration shutter screws, slide the aeration shutter to the position shown in figure 28 and tighten the fixing screws.

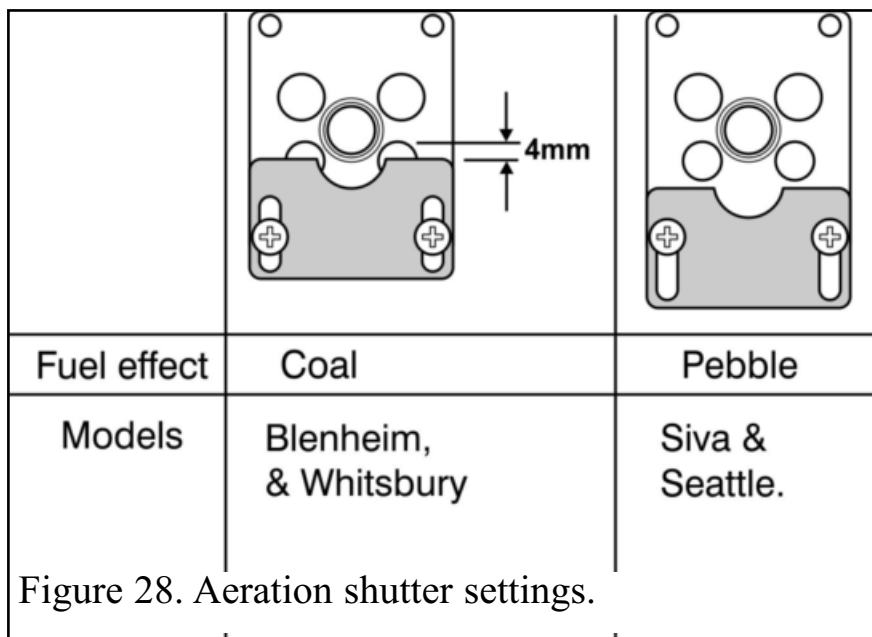

## 16.2 To remove the burner unit.

1. Remove the firefront.
2. Remove the ceramic fuel effect. The ceramic fuel effect may cause staining / discolouration to decorative surfaces. It is therefore advisable to protect decorative surfaces.
3. Support the inlet elbow to avoid straining the pipework and disconnect the appliance from the inlet elbow.
4. Detach the burner unit from the hotbox by removing two screws (See figure 29).

## 16.3 To remove the pilot unit.

1. Remove the burner unit (See section 16.2)
2. If lying the burner on its back, ensure that the work surface is suitably protected. This will avoid damage to the work surface.

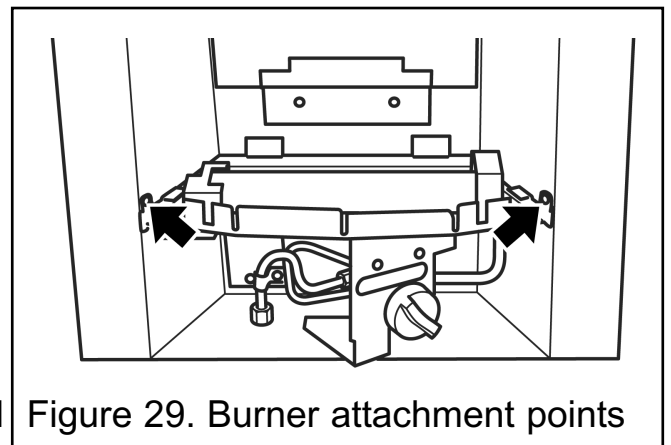

# INSTALLER GUIDE

3. Detach the pilot pipe from the pilot unit.
4. Detach the thermocouple from the gas valve
5. Detach the electrode lead from the rear of the piezo spark generator on the gas valve.
6. Remove the two screws securing the pilot unit (See figure 30).
7. Refit in the reverse order.

*Note: The pilot unit is an atmosphere sensing device. It must be replaced as a whole assembly. Its individual components are not separately replaceable.*

## 16.4 To remove the gas valve.

(See figure 31).

1. Remove the burner unit (See section 16.2).
2. If lying the burner on its back, ensure that the work surface is suitably protected. This will avoid damage to the work surface. Turn the burner unit upside down.
3. Detach the pilot pipe from the gas valve.
4. Detach the inlet pipe.
5. Detach the injector pipe.
6. Detach the electrode lead from the rear of the piezo spark generator on the gas valve.
7. Remove the control knob by pulling forward.
8. Remove the thermocouple by unscrewing the thermocouple nut at the gas valve.
9. Remove the hexagonal nut securing the gas valve to the mounting bracket.
10. Remove the gas valve.
11. Refit in the reverse order.

## 16.5 To remove the burner.

(See figure 32).

1. Remove the burner unit (See section 16.2).
2. Support the elbow injector and unscrew the injector nut.
3. Remove the two screws from the burner clamping plate (See figure 32).
4. Lift the right hand side of the burner, slide it to the right and lift clear
5. Refit in reverse order.

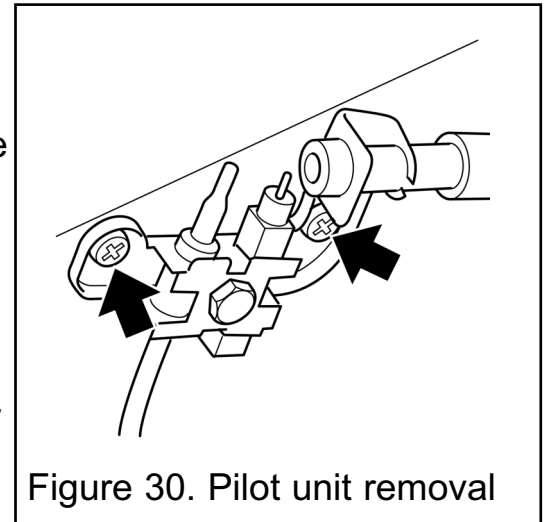

Figure 30. Pilot unit removal

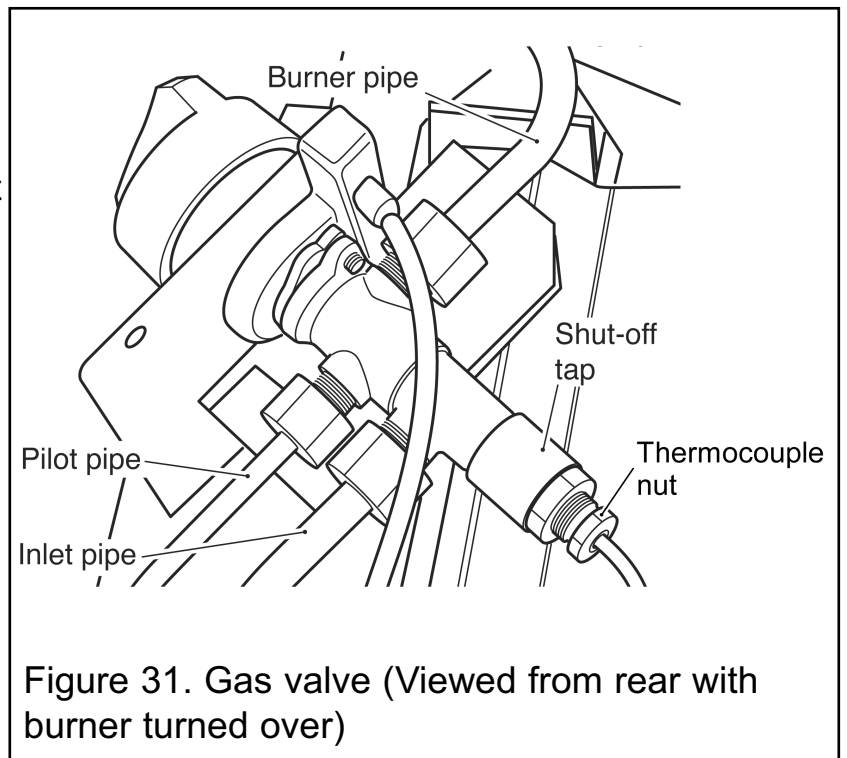

Figure 31. Gas valve (Viewed from rear with burner turned over)

# INSTALLER GUIDE

## 16.6 To remove the main burner injector.

(See figure 33).

1. Remove the burner (See section 16.5).
2. Remove the burner clamping screw (See figure 33).
3. Unscrew the injector from the burner.
4. Refit in the reverse order.

## 16.7 To remove the appliance from the fireplace.

1. Remove the burner unit (See section 16.2).
2. Slacken the hexagonal adjusters on the cable adjusters and unscrew the thumbscrews to release the cables.
3. Refit as described in the relevant installation sections. Make sure gas soundness, sealing, spillage test and performance are satisfactory.

## 16.8 To remove the magnetic three piece fascia.

1. Remove the firefront.
2. The fascia is made up of three trims. These trims are held in place by magnets. Remove the top trim by pulling forward. Place carefully aside (See figure 34).
3. Remove the side trims by pulling forward. Place carefully aside (See figure 34).
4. Refit in the reverse order. Make sure that the top corners of the fascia have no gaps.
5. Siva fascia same as in Figure 34 except the fascia is all one piece.

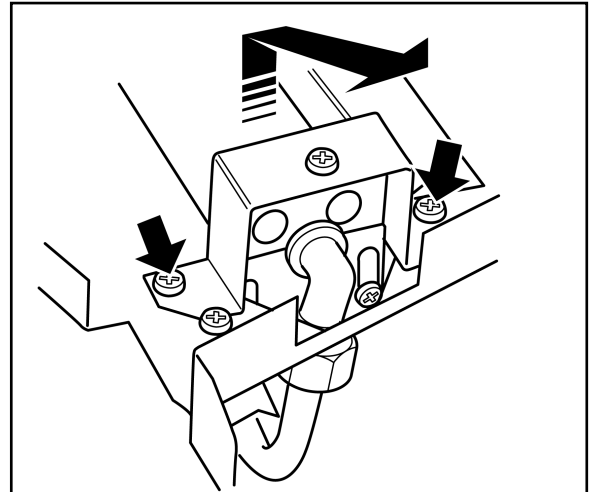

Figure 32. Removal of burner

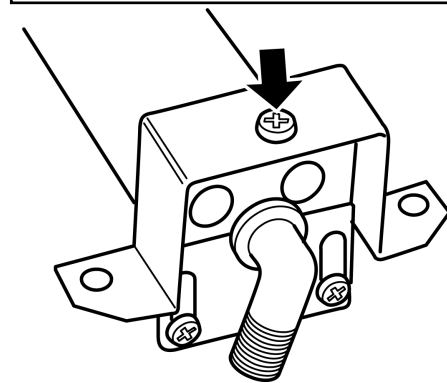

Figure 33. Main burner injector removal

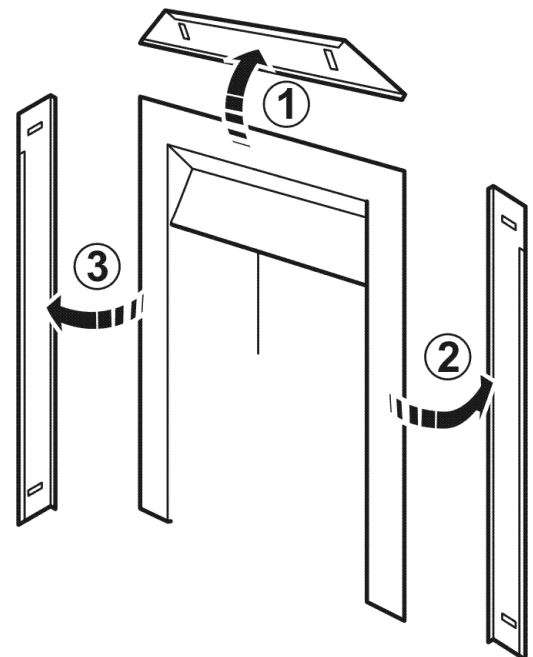

Figure 34. Removal of fascia

# OWNER GUIDE

FOR WARRANTY AND SERVICE INFORMATION  
SEE PAGES 48 TO 52

# OWNER GUIDE

## LIST OF CONTENTS

<u>Section</u>	<u>Page</u>
<b>SAFETY</b>	<b>40</b>
<b>APPLIANCE DIMENSIONS AND CLEARANCES</b>	<b>42</b>
<b>GAS CONSUMPTION</b>	<b>43</b>
<b>OPERATING YOUR FIRE</b>	<b>44</b>
The Oxysafe flame sensing and flue blockage safety system.	44
Lighting the pilot.	44
Lighting the burner.	45
Selecting the heat setting.	45
Turning the fire back to pilot setting.	45
Turning the appliance off.	45
Lighting with a taper.	45
<b>CLEANING YOUR FIRE</b>	<b>46</b>
Metal parts.	46
Ceramic fuel effect and rear wall.	46
Burner.	46
<b>CERAMIC FUEL EFFECT FITTING</b>	<b>47</b>
<b>MAINTENANCE</b>	<b>47</b>
Regular maintenance.	47
Replacement ceramics.	47
<b>WARRANTY, SERVICE AND BENCHMARK</b>	<b>48-54</b>
<b>BENCHMARK COMMISSIONING CHECKLIST</b>	<b>50</b>
<b>BENCHMARK SERVICE RECORD</b>	<b>51</b>
<b>SERIAL NUMBER LABEL</b>	<b>52</b>

This gas fire is designed to meet the most stringent quality, performance and safety requirements to provide you with many years' trouble-free service.

This guide aims to improve your understanding and appreciation of your gas fire by providing simple and informative instructions to ensure that you benefit from the excellent performance and features it has to offer.

# OWNER GUIDE

## SAFETY

### IF YOU SMELL GAS

- DON'T SMOKE.
- EXTINGUISH ALL NAKED FLAMES.
- DON'T TURN ELECTRICAL SWITCHES ON OR OFF.
- TURN OFF THE GAS SUPPLY AT THE METER OR TANK AS APPROPRIATE.
- OPEN DOORS AND WINDOWS TO GET RID OF THE GAS.
- IMMEDIATELY CALL THE GAS EMERGENCY SERVICE FROM A NEIGHBOURS PHONE - SEE YOUR LOCAL TELEPHONE DIRECTORY.

**Do** have the fire installed by a competent person. In the United Kingdom, installation must be in accordance with the latest edition of the Gas Safety (installation & use) Regulations. In the Republic of Ireland, installation must be in accordance with all national and local regulations in force.

**Do** have the chimney swept prior to installation if it was previously used for solid fuel.

**Do** have the fire installed in accordance with the installation instructions.

**Do** provide a minimum clearance of 750mm from the base of the fireplace opening to any shelf made of wood or other combustible material where the shelf is not more than 150mm deep. For a shelf deeper than 150mm, add 12.5mm to the clearance for every 25mm of additional shelf depth (See figure 1).

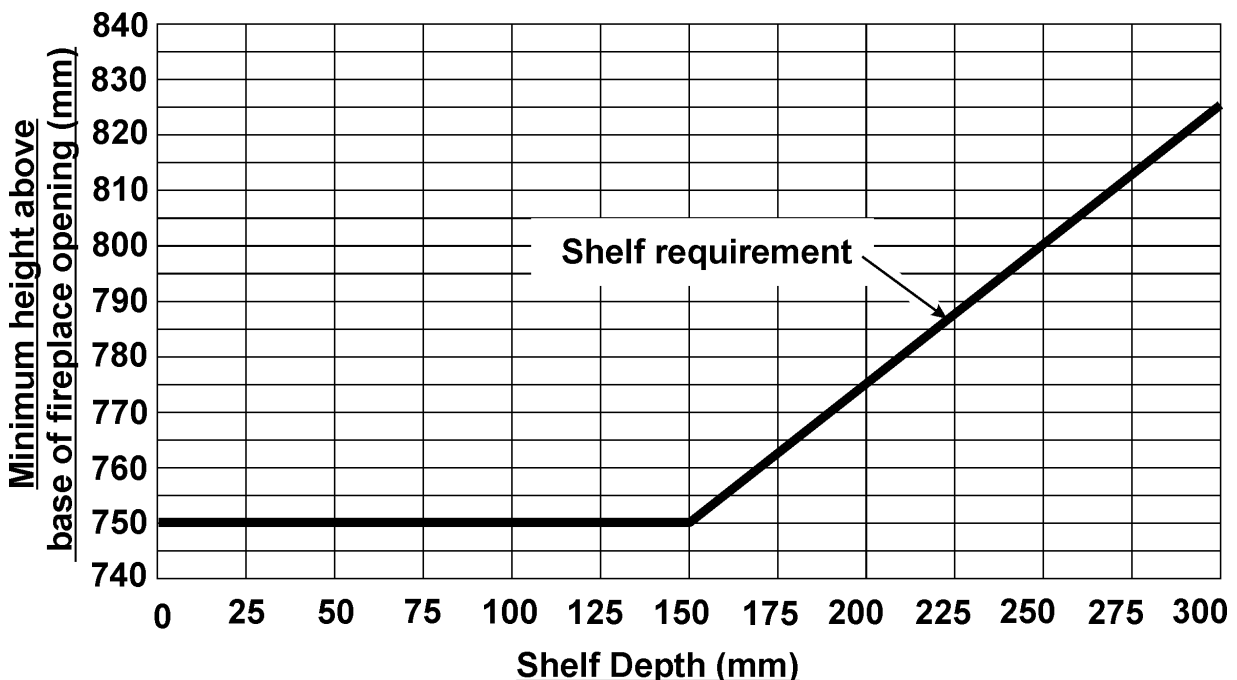

Figure 1. Combustible shelf clearances



# OWNER GUIDE

**Do** always use a fireguard complying with BS 8423 for the protection of young children, pet animals, the elderly or infirm.

**Do** wait three minutes before attempting to relight if the fire is switched off or the flames are extinguished for any reason. (Your fire is fitted with a safety device that will automatically shut off the gas supply to the fire, if for any reason, the flame goes out).

**Do** get advice about the suitability of any wall covering near your fire. Soft wall coverings (e.g. embossed vinyl, etc.) which have a raised pattern are easily affected by heat. They may, therefore, scorch or become discoloured when close to a heating appliance. Please bear this in mind whenever you are considering redecorating.

**Do** provide a minimum side clearance as detailed in figure 1. Please bear this in mind if ever you are altering the room.

**Don't** hang clothing, towels or any other fabrics over the fire.

**Don't** put more loose ceramic fuel effect pieces on the fire than the number given in the installer guide or use any ceramic fuel effect pieces other than those authorised for this fire. Incorrect combustion and health hazard could result.

**Don't** put paper or other materials onto your fire.

**Don't** use the fire with damaged base ceramics.

**Don't** place any combustible material (rugs, carpet, plastic tiles, etc.) on the hearth

**Don't** attempt to clean or service the fire until it has been switched off and allowed to cool completely.

# OWNER GUIDE

## APPLIANCE DIMENSIONS AND CLEARANCES

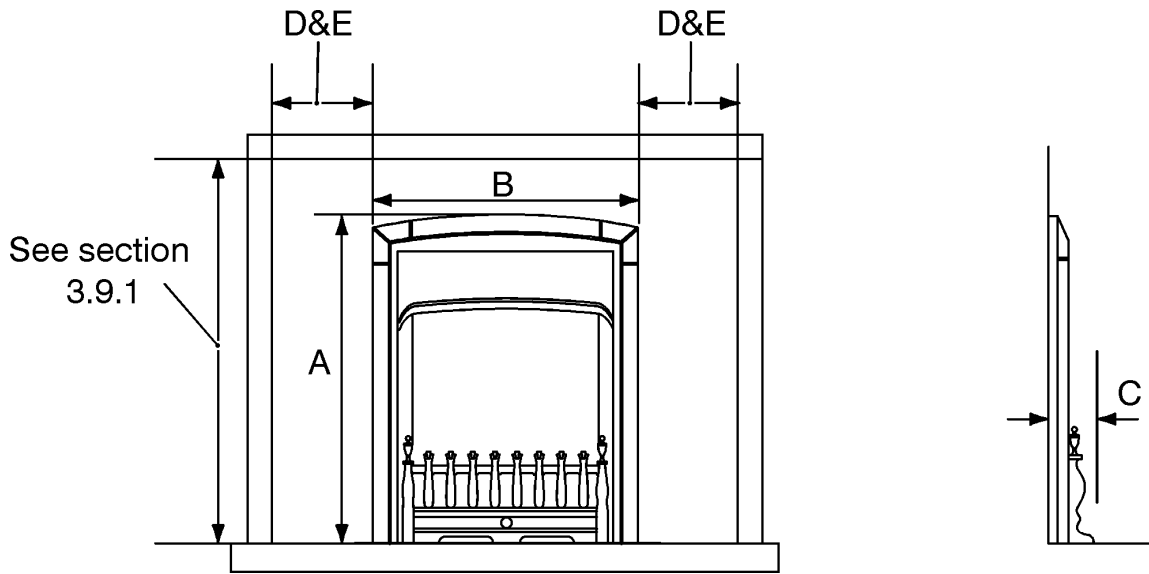

	Key				
	A	B	C	D	E
Model	Height (mm)	Width (mm)	Depth into room (mm)	Minimum mandatory clearance to <b>combustible</b> surfaces projecting beyond the front of appliance (mm).	Recommended clearance to <b>non-combustible</b> surfaces for access purposes (mm).
Blenheim	587.5	450	85	100	10
Seattle	587.5	450	63	100	10
Siva	590	455	80	100	10
Whitsbury	588	450	73	100	10

Figure 2. Appliance dimensions and clearances (Fascia may differ from that shown)  
 (The appliance dimensions 'A', 'B' & 'C' shown in the table are subject to manufacturing tolerance)

# OWNER GUIDE

## GAS CONSUMPTION

### **Model 956**

Has a maximum natural gas input of 6.0kW (Gross)

Has a maximum natural gas output of 3.05kW

Has a minimum natural gas input of 2.3kW (Gross)

Has a minimum natural gas output of 1.15kW

Has a maximum natural gas input of 5.4kW (Net)

Has a maximum natural gas output of 3.05kW

Has a minimum natural gas input of 2.07kW (Net)

Has a minimum natural gas output of 1.15kW

### **Model 956 when converted using kit number 0595221**

Has a maximum propane gas input of 6.1kW (Gross)

Has a maximum propane gas output of 3.1kW

Has a minimum propane gas input of 3.8kW (Gross)

Has a minimum propane gas output of 1.8kW

Has a maximum propane gas input of 5.61kW (Net)

Has a maximum propane gas output of 3.1kW

Has a minimum propane gas input of 3.5kW (Net)

Has a minimum propane gas output of 1.8kW

# OWNER GUIDE

## OPERATING YOUR FIRE

### PLEASE NOTE

When operating your fire for the first time, some vapours may be given off which may cause a slight odour and could possibly set off any smoke alarms in the immediate vicinity. These vapours are quite normal with new appliances. They are totally harmless and will disappear after a few hours use.

### The Oxysafe flame sensing and flue blockage safety system.

For your safety, this appliance is fitted with a flue blockage safety device which will shut down the appliance in the event of abnormal flue conditions. **This device is NOT a substitute for an independently mounted Carbon Monoxide detector.**

The device will also automatically shut off the gas supply to the fire if the pilot flame goes out due to lack of oxygen or for any other reason.

**If this device starts to repeatedly shut off the gas, get expert advice.**

This device incorporates a probe which senses that the heat from the pilot flame is correct. If this probe is cool, the device will prevent any gas flow unless the control knob is kept depressed at the 'PILOT / IGN' position.

If, for any reason, the flames go out when the fire is hot or if the fire is turned off when hot, always **wait at least three minutes before attempting to relight.**

### Lighting the pilot.

This fire is controlled by a 4-position gas tap mounted on the front leg of the appliance (See figure 3). In addition to the 'OFF' position there is a pilot light and 2 heat control settings.

– Depress the control knob and turn SLOWLY anticlockwise towards the 'PILOT / IGN' position. A spark should be generated at the pilot while turning. The spark should ignite the pilot. The pilot flame can be seen through the lower left hand opening in the front of the fuel effect bed.

– Keep the button depressed at the 'PILOT / IGN' position for a further ten seconds. This will prevent the flame-sensing device from shutting off the gas while its probe warms up.

– If the pilot does not ignite instantly, repeat procedure. **If after 10 seconds pilot ignition has not occurred, turn the control knob back to the 'OFF' position, wait for 3 minutes and then repeat the ignition procedure.**

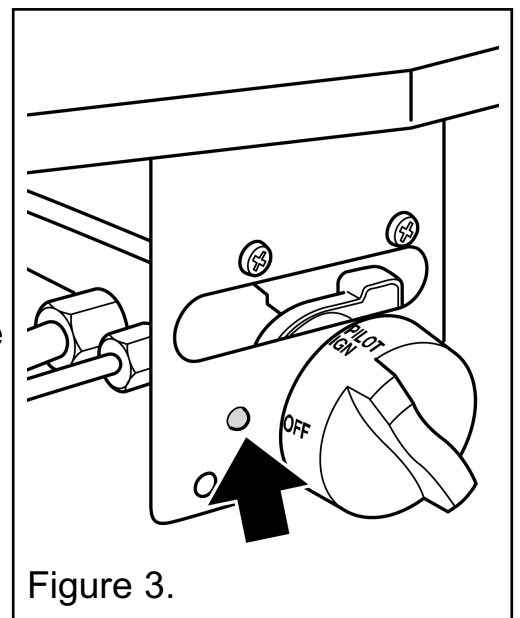

Figure 3.

# OWNER GUIDE

## Lighting the burner.

– Once the pilot light is established, the main burner can be lit by depressing and turning the control knob anticlockwise to the 'HIGH' position.

## Selecting the heat setting.

– In order to change from one setting to another depress the control knob slightly and turn the knob to the required position. Any setting from 'LOW' to 'HIGH' may be selected.

**Note:** *The appliance will operate to its maximum potential if the flue is primed during the first 20-30 minutes of operation. To do this, simply operate the appliance at its "HIGH" setting. This will also burn off any carbon deposits that may have formed during previous operations. If operating the appliance for long periods it is beneficial to change between settings. This will help to remove any carbon deposits that may form during operation.*

## Turning the fire back to pilot setting.

– Depress the control knob and turn clockwise until the 'PILOT / IGN' setting is reached.

## Turning the appliance off.

– Make sure that the control knob is in the 'PILOT / IGN' position. Depress the control knob and turn clockwise to the 'OFF' position.

– **Wait at least three minutes before relighting.**

## Lighting with a taper.

(See figure 4).

In the unlikely event of failure of the ignition spark, the pilot can be lit by a taper or long spill. Insert the taper or spill through the lower left hand opening in the front of the fuel effect bed.

Follow the section 'Lighting the pilot' as described previously.

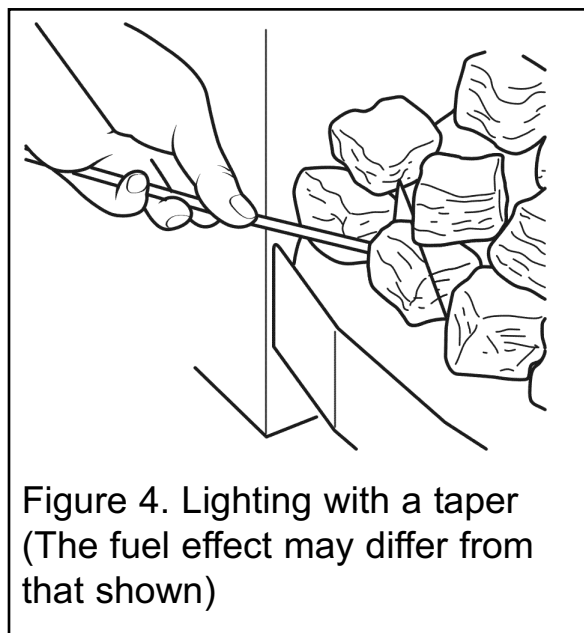

Figure 4. Lighting with a taper  
(The fuel effect may differ from that shown)

# OWNER GUIDE

## CLEANING YOUR FIRE

To maintain the high performance and quality finish of your Valor Fires appliance, please follow these guidelines:

- Before attempting to clean the fire, please remember to turn off the fire and wait for the appliance to cool completely. The fire will retain heat for some time before cleaning can begin.
- If any pieces of debris are found in the firebox, have the chimney inspected before further use.

### **Metal parts.**

- Clean the metal parts with a slightly damp cloth and then dry.
- Do not use abrasive cleaners as these will scratch the fire surface.
- **Fascia and firefront** - Clean the metal parts with a slightly damp cloth and then dry. This may not work on fingerprints etc. In this case apply a very small amount of 'baby oil' to a lint free, non-abrasive cloth and wipe over the surface. Use a clean cloth to wipe off the oil.

### **Ceramic fuel effect and rear wall.**

- **This product uses fuel effect pieces and burner compartment rear wall containing Refractory Ceramic Fibres (RCF), which are man-made vitreous silicate fibres. Excessive exposure to this material may cause irritation to eyes, skin and respiratory tract. Consequently, it is important to take care when handling these articles to ensure that the release of dust is kept to a minimum.**
- Light coatings of soot will usually be burnt off during the normal operation of the fire.
- Should any soot accumulation become excessive, the fuel effect pieces and rear wall should be removed from the fire for cleaning.
- Cleaning should be carried out in a well ventilated area or in the open air by gently brushing with the pieces held away from your face so that you avoid inhaling the dust.
- We suggest that you remove the ceramic fuel effect pieces in the reverse order to that shown in the ceramic fuel effect installer and owner guide.

### **Burner.**

- The burner surface can be carefully cleaned to remove any loose particles after taking off the ceramic fuel effect pieces . Make sure that no particles are pushed into the burner holes.

# OWNER GUIDE

## CERAMIC FUEL EFFECT FITTING

The installer and owner guide for the ceramic fuel effect is separate from this guide. The installer may have attached it to this guide or placed it inside. It is important that the installer and owner guide for the ceramic fuel effect is followed correctly. If replacing the ceramic fuel effect, where a new guide is supplied, follow the installer and owner guide supplied with the replacement fuel effect.

Keep the replacement installer and owner guide with this owner guide for future reference.

## MAINTENANCE

### **Regular maintenance.**

In order to achieve and maintain high levels of personal safety and performance efficiency, it is essential that the opening at the back of the fire and the flue are kept clear of any form of obstruction. It is possible that deposits of mortar or soot could fall and accumulate causing the flue to be blocked or restricted and so preventing proper clearance of dangerous exhaust fumes.

In the United Kingdom it is the law that a landlord must have any gas appliance, flue and pipework which is situated in a tenant's premises checked for safety at least every twelve months by a competent person (A GAS SAFE REGISTER operative). We recommend that all gas appliances and their flues, wherever situated, are checked annually.

The service engineer must complete the relevant Service Record on **Page 51** after each service.

- **When fitting replacement parts it is important that only approved parts are used for maximum safety.**

### **Replacement ceramics.**

If you wish to replace any of the ceramic fuel effect pieces, spare parts are available nationwide via the **GDC Helpline** number.

# OWNER GUIDE

## WARRANTY AND SERVICE

### Standard Warranty Terms & Conditions

The warranty is for 12 months subject to contract.

In the United Kingdom servicing can be carried out either by a **GDC** service engineer or a **GAS SAFE REGISTER** engineer. Outside of the United Kingdom servicing can be carried out either by a **CORGI** or **GAS SAFE REGISTER** engineer.

You must register your fire with by calling our telephone registration line on **08444 810 214**.

This product should be serviced annually to optimise its safety, efficiency and performance. The GAS SAFE REGISTER service engineer must complete the relevant Service Record on the Benchmark Checklist after each service.

It is also a requirement of the warranty that the fire has an annual service (every 12 months) in accordance with the installation and servicing instructions, performed by a GAS SAFE REGISTER engineer, (CORGI or GAS SAFE REGISTER outside of UK)



### Benchmark Checklist/Service Record

Please ensure that the installer has fully completed the Benchmark Checklist on the inside back pages of the installation instructions supplied with the product and that you have signed it to say that you have received a full and clear explanation of its operation. The installer is legally required to complete a commissioning checklist as a means of complying with the appropriate Building Regulations (England and Wales).

Installations carried out in England and Wales must be notified to Local Area Building Control either directly or through a Competent Persons Scheme. A Building Regulations Compliance Certificate will then be issued to the customer who should, on receipt, write the Notification Number on the Benchmark Checklist.

The filled in Benchmark Checklist/Service Record by the installer will be required in the event of any warranty (UK and Ireland installation).

After servicing, complete the relevant "Service Interval Record" section of the Benchmark Checklist located on the inside back pages of this document.



# OWNER GUIDE

## **Our promise to you**

If you experience a fault with your new fire, we aim to provide a safe and high quality repair service supported by our dedicated national network of highly skilled engineers. If your installer can't resolve the problem for you, we will do everything we can to get an engineer out to you as quickly as possible. Nothing in this warranty will affect your statutory rights.

## **What you need to do if you experience a problem with the operation of the fire:**

- You should always contact your installer first, because the cause of the fault may not be related to the fire.
- If your installer confirms that the fault is with the fire and they can't repair it, our friendly customer service team is on hand to help.
- Simply call our UK GDC Helpline on **0844 879 35 88** or from the Republic of Ireland call **01 842 8222** for any general advice that you may need.

When calling the **Helpline**, it would be helpful if you could have the following information to hand:-

1. Fire serial number and fascia code (Located on the information label - See figure 5 on page 52)\*.
2. Date of installation\*.
3. Your installer name and address details\*.
4. Fire make and model number\*.
5. Annual Service record details\*
6. Proof of purchase (if you do not have the fire serial number)

**\*Note: details 1 – 5 should be recorded as part of the Benchmark Checklist / Service record at the end of this guide.**

## **What this warranty covers**

Free of charge repair or replacement of components found to be of faulty manufacture.

Free of charge replacement of the complete unit providing the failure is related to a manufacturing fault that cannot be repaired or is uneconomic to repair.

## **What this warranty does not cover**

Repairs to fires which haven't been installed and commissioned properly and as set out in the installation instructions.

Faults caused by inadequate supply of gas or electricity (where applicable).

Reimbursement of any third party repair or replacement costs that we haven't been told about or agreed with you in advance.

Compensation or consequential losses (e.g. loss of earnings, business losses, stress and inconvenience) arising from a production breakdown, including repair delays caused by factors outside our reasonable control.

# OWNER GUIDE

## GAS FIRE COMMISSIONING CHECKLIST

This Commissioning Checklist is to be completed in full by the competent person who commissioned the gas fire as a means of demonstrating compliance with the appropriate Building Regulations and then handed to the customer to keep for future reference.

Failure to install and commission according to the manufacturer's instructions and complete this Benchmark Commissioning Checklist will invalidate the warranty. This does not affect the customer's statutory rights.

Customer name:										Telephone number:									
Address:																			
Gas Fire make and model:																			
Gas Fire serial number:																			
Commissioned by (PRINT NAME):										Gas Safe register number:									
Company name:										Telephone number:									
Company address:																			
										Commissioning date:									
Building Regulations Notification Number (if applicable):																			
<b>Site Requirements</b>																		Yes	N/A
Was the chimney checked to ensure it only serves one flue/fire, has no obstructions and is continuous?																			
Has any debris at the base of the chimney been removed?																			
For brick chimney installations is there enough depth for 12 litres of debris, or precast flues 2 litres of debris? (see instructions for debris gap details)																			
Have damper and register plates been removed or locked in the fully open position ensuring correct size of flue is maintained?																			
If previously used for solid fuel has the chimney been thoroughly swept?																			
If the chimney is pre-cast has the inside of the flue been checked for extruded cement / sealant which must be removed?																			
Has the fire place been checked for under-floor air supply which must be sealed off?																			
Has the chimney been inspected prior to fitting the gas fire to ensure that it is in good condition?																			
Has the structure of the chimney been checked for leakage using a smoke pellet test? (See BS5440-1 for details).																			
<b>Ventilation</b>																			
Does the installation require any additional ventilation requirements as detailed in the manufacturer's instructions?																			
<b>Hearth Requirements- where fitted</b>																			
Is the hearth constructed from non -combustible material?																			
Is the hearth a minimum of 12mm thick with a minimum floor to top surface of 50mm?(BS5871) or as per manufacturer's instructions?																			
Is the hearth for open fronted fires a minimum of 760mm wide and has 300mm projecting from the fire opening (BS6871) or to manufacturer's instructions?																			
Mounting height (where applicable) has the fire been installed to the correct mounting height- as per manufacturer's instructions?																			
<b>Firebox and Fuel Bed</b>																			
Has the fuel bed, coals, pebbles etc. been fitted to manufacturer's instructions?																			
<b>Gas Supply</b>																			
Has an isolation tap/restrictor inlet elbow been fitted for servicing?																			
Has the gas supply been thoroughly purged prior to connection to remove any debris?																			
Has a gas tightness test been completed prior to breaking into the gas supply and following completion of installation?(IGEM/UP/1B)																			
Record burner gas pressure reading? If only the supply pressure is available a gas rate must be undertaken.(GSIUR REG26/9C)																			
Record dynamic inlet gas pressure (working pressure) reading (all gas appliances running)																			
<b>Spillage test</b>																			
Installation passes smoke match test with any extractor fans turned on (see manufacturer's instructions)																			
<b>Installation</b>																			
Has the gas fire been installed and commissioned in accordance with manufacturer's instructions?																			
Has the fire been installed with the correct clearance to combustile materials, as per manufacturer's instructions?																			
The operation of the appliance and controls have been demonstrated to the customer including battery replacement where applicable?																			
The manufacturer's literature, including Benchmark Checklist and Service record has been explained and left with the customer?																			
Has the appliance been registered with the Local Authority as detailed on the Gas Safe web site and is a legal requirement and forms part of the warranty?																			
Customer's Signature:										Commissioning Engineer's Signature:									
(To confirm satisfactory demonstration and receipt of manufacturer's literature)																			

\*All installations in England and Wales must be notified to be Local Authority Building Control (LABC) either directly or through a Persons Scheme. A Building Regulations Compliance Certificate will then be issued to the customer.



# OWNER GUIDE

## SERVICE RECORD

It is essential that your gas fire is serviced regularly and that the appropriate Service Interval Record is completed.

### Service Provider

Before completing the appropriate Service Record below, please ensure you have carried out the service as described in the manufacturer's instructions. Always use the manufacturer's specified spare part when replacing controls.

<b>SERVICE 01</b>	Date:	<b>SERVICE 02</b>	Date:
Engineer name:		Engineer name:	
Company name:		Company name:	
Telephone No:		Telephone No:	
Gas safe register No:		Gas safe register No:	
Comments:		Comments:	
Signature		Signature	
<b>SERVICE 03</b>	Date:	<b>SERVICE 04</b>	Date:
Engineer name:		Engineer name:	
Company name:		Company name:	
Telephone No:		Telephone No:	
Gas safe register No:		Gas safe register No:	
Comments:		Comments:	
Signature		Signature	
<b>SERVICE 05</b>	Date:	<b>SERVICE 06</b>	Date:
Engineer name:		Engineer name:	
Company name:		Company name:	
Telephone No:		Telephone No:	
Gas safe register No:		Gas safe register No:	
Comments:		Comments:	
Signature		Signature	
<b>SERVICE 07</b>	Date:	<b>SERVICE 08</b>	Date:
Engineer name:		Engineer name:	
Company name:		Company name:	
Telephone No:		Telephone No:	
Gas safe register No:		Gas safe register No:	
Comments:		Comments:	
Signature		Signature	
<b>SERVICE 09</b>	Date:	<b>SERVICE 10</b>	Date:
Engineer name:		Engineer name:	
Company name:		Company name:	
Telephone No:		Telephone No:	
Gas safe register No:		Gas safe register No:	
Comments:		Comments:	
Signature		Signature	



# OWNER GUIDE

Model

Serial number (Can be found on information label - See figure 5)

SERIAL NUMBER LABEL  
TO BE AFFIXED HERE

A LABEL CONTAINING THE SERIAL NUMBER MAY HAVE BEEN PLACED INSIDE THIS BOX.

Fascia name (Block Capitals)

Fascia code - Can be found on information label (Block Capitals)

FASCIA LABEL  
TO BE AFFIXED HERE

A LABEL CONTAINING THE FASCIA CODE MAY HAVE BEEN PLACED INSIDE THIS BOX.

Brand (Please tick)

Valor

Other.....

Date of Installation

D D M M Y Y

