



# Installation and Operating Manual

ambiente stoves





## PREFACE - QUALITY PHILOSOPHY

You have decided in favour of a SPARTHERM stove; thank you for your confidence in our company.

In a world of excess and mass production, our company stands for the values expressed by our owner, Gerhard Manfred Rokossa:

"High technical quality combined with contemporary design and service to the satisfaction of our customers so they will recommend us to others". Together with our specialist trade partners, we offer a range of first-class products, which not only evoke passion, but also engender feelings of comfort and security. To ensure precisely this, we encourage you to read the operating manual carefully so that you can become familiar with your stove quickly and thoroughly.

In addition to information on use, these instructions also include important details on care and operation to guarantee your safety and to protect the value of your stove as well as useful tips and guidance. Moreover, we show you how you can operate your stove in an environmentally responsible manner.

For further enquiries, please contact your specialist dealer.

We hope you enjoy your new fireplace.

Your SPARTHERM Team

G.M. Rokossa

# CONTENTS OF SPARTHERM AMBIENTE STOVE OPERATING MANUAL

General information	4	2.8.5 Electrical connection	25
		2.8.6. Integration in a heating system	26
		2.8.7 Return flow temperature riser	28
1. Inspected quality	5	3. Operating instructions	29
1.1. Scope of delivery	5	3.1 General information on operation	29
1.2. Transport damage	5	3.2 S-Thermatik Mini	30
2. Installation instructions	5	3.2.1 Initial commissioning of the S-Thermatik Mini	30
2.1. Basic requirements for installation	6	3.2.2 Functional testing of the S-Thermatik Mini	31
2.1.1. Installation site	6	3.3 Functioning of the rotary base	32
2.1.2. Multiple connection	6	3.4 Rating plate	33
2.2. Technical data	6	3.5 Operation of the water heat exchanger on the ambiente a4 H <sub>2</sub> O / a6 H <sub>2</sub> O	33
2.3. Installation / assembly	8	4. Combustion	34
2.3.1. Assembly of the exhaust gas stub	9	4.1 Initial commissioning	34
2.3.2. Assembly of the faceplate on the rotary base	12	4.1.1 Initial commissioning of the ambiente a4 H <sub>2</sub> O / a6 H <sub>2</sub> O	34
2.3.3.2		4.2 Combustion air regulation	35
2.4. Combustion air supply	16	4.3 Heating up / Burning	36
2.4.1. Non-room air sealed operation (RLA)	16	4.3.1 Adding wood / End of the combustion process	36
2.4.2. Room air sealed operation (RLU)	16	4.3.2 Hourly wood consumption rate	37
2.4.3. Separate combustion air supply	16	4.4 Controlling heat output	37
2.5. Fire protection	19	4.5 Room heating capacity / Indoor climate	37
2.6. Shut-off devices	22	4.6 Heating in the transitional period / Unfavourable weather conditions	38
2.7. Connecting pieces	22	5. Fuel	38
2.8 Installation of the water-bearing components of the ambiente a4 H <sub>2</sub> O / a6 H <sub>2</sub> O	22	5.1 CO <sub>2</sub> neutrality	39
2.8.1 ambiente a4 H <sub>2</sub> O / a6 H <sub>2</sub> O connections	2 3	5.1.1 Wood storage	39
2.8.2 Basic requirements for installation	24	5.2 Your contribution to environmental protection	39
2.8.3 Thermal discharge safety device (TDS)	24		
2.8.4 Thermal pump control of the ambiente a4 H <sub>2</sub> O / a6 H <sub>2</sub> O	25		

6. Cleaning and care	40
6.1 Cleaning of firebox / cladding parts	40
6.2 Firebox lining	41
6.3 Chimney fire	43
6.4 Maintenance	44
6.4.1 Lubrication guide for door locks with SmartClose	44
6.4.2 Maintenance of the water heat exchanger of the ambiente a4 H <sub>2</sub> O / a6 H <sub>2</sub> O	45
6.4.3 Venting the water heat exchanger of the ambiente a4 H <sub>2</sub> O / a6 H <sub>2</sub> O	45
6.5 Cleaning the water heat exchanger of the ambiente a4 H <sub>2</sub> O / a6 H <sub>2</sub> O	45
7. Troubleshooting	47
7.1 Water heat exchanger of the a4 H <sub>2</sub> O / a6 H <sub>2</sub> O	50
8. General warranty conditions	50
8.1 Area of application	50
8.2 General information	51
8.3 Warranty period	51
8.4 Warranty requirements	51
8.5 Warranty disclaimer	51
8.6 Elimination of defects / repair	52
8.7 Extension to the warranty period	52
8.8 Spare parts	52
8.9 Liability	52
8.10 Closing remarks	52
9. Commissioning protocol	53
9.1 Commissioning protocol of the ambiente a1/a2/a3/a4/a5/a7/a8	53
9.2 Commissioning protocol of the ambiente a4 H <sub>2</sub> O / a6 H <sub>2</sub> O	54

## GENERAL INFORMATION

Before assembling and installing your stove (ambiente a1/a1 RLU/a2/a2 RLU/a3/a3 RLU/a4/a4 RLU/a4 H<sub>2</sub>O/a4 H<sub>2</sub>O RLU/a5/a6/a6 H<sub>2</sub>O/a7/a8) please consult your district master chimney sweep.

He will advise you of building law regulations, the suitability of your chimney, and will conduct the acceptance procedure for your stove. The chimney calculation is executed in accordance with DIN EN 13384 with the value triplet specified in this manual (see technical data).

important for small children, elderly or infirm persons: As is the case with all heating devices, it is expedient that you attach a protective guard - (change fixture to guard) for these groups of persons, as the view pane and the cladding parts of the stove can become extremely hot Caution: Risk of burn injuries!

Never leave these groups of persons unattended near the stove when a fire is burning or has just been extinguished! The stove should never be operated for an extended period of time unattended.

# 1. CERTIFIED QUALITY

OUR STOVES ARE TESTED IN ACCORDANCE WITH DIN EN 13240. DECLARATION OF PERFORMANCE IS AVAILABLE AND CAN BE VIEWED AT WWW.SPARTHERM.COM

These stoves have self-closing combustion chamber doors which means the doors are only opened when the fireplace has to be serviced (e.g., to clean the combustion chamber or add more fuel). For safety reasons, the closing mechanism must not be tampered with; furthermore, any such action would render the warranty and operating licence null and void. The guarantee and operating licence are also rendered invalid if the customer modified the technology of any other area of the stove.

## 1.1 SCOPE OF DELIVERY

- Combustion chamber made of eboris 1300 (refractory concrete) chamotte
- Primary and secondary air supply
- Pull-out ash drawer
- Self-closing combustion chamber door with high-temperature-resistant ceramic glass pane
- Heat-resistant glove (**Caution:** The heat-resistant glove provided serves only as thermal protection and is not fire-proof!)
- Rating plate (For attachment see „3.4 Rating plate“ on page 33)
- Supplied pre-assembled in transport-friendly disposable cardboard packaging
- Optional storage stones
- Integrated cleaning system (a4 H<sub>2</sub>O/RLU and a6 H<sub>2</sub>O only)
- Pump thermostat, thermal discharge safety device  $\frac{3}{4}$ “, vent valve (ambiente a4 H<sub>2</sub>O and a6 H<sub>2</sub>O only).

## 1.2 TRANSPORT DAMAGE

Please inspect the goods **immediately** upon delivery (visual inspection). Make a note of any damage on your delivery document and inform your stove or fireplace fitter. Protect the visible elements of the stove from soiling and damage during installation. Only permitted and sufficiently strong transport aids may be used to transport your stove.

The following points must be noted to ensure safe and problem-free transport:

- The stove should always be transported in the upright position or tilted slightly backwards (the back of the stove is labelled).
- A hand truck used as a handling aid must load the stove from the rear only

# 2. INSTALLATION INSTRUCTIONS

The assembly and installation of your stove should be carried out by a specialist. Before your stove is assembled and installed you should meet with the master chimney sweep responsible for such matters in your area to discuss the suitability of your chimney and the installation location and to clarify other matters.

## 2.1 BASIC REQUIREMENTS FOR INSTALLATION

For installation, connection and operation of the stove, all necessary national and European standards, as well as local regulations (DIN, DIN EN, state construction ordinances, firing ordinances, etc.) must be complied

with and applied. The list of regulations given below is not exhaustive.

FeuVo / LBO / VKF	Firing Installation Ordinance of the respective German Federal State / State building or fire protection regulations VKF (Switzerland)
BImSchV Stage 1	First stage of the Ordinance on the Implementation of the Federal Immission Control Act
TR-OL	TROL Regulations of the German Tiled Stove and Air Heating Constructors Association (ZVSHK)
	Connecting flue pipes for heat generating systems
DIN EN 13240	Stoves / solid fuel room heaters
DIN 18896	Solid-fuel fireplaces Technical rules for installation and operation
DIN EN 13384	Chimneys - Thermal and fluid dynamic calculation methods
DIN 18160-1/2	Chimneys / house chimneys
DIN 4751 / DIN EN 12828	Heating systems in buildings – Planning hot water systems
VDI 2035	Water conditioning for heating systems
LRV	LRV (Switzerland)
Art. 15a	B-VG (Austria)

This list of regulations and requirements does not claim to be complete. Fireplaces may only be installed in rooms and places where the location, construction situation and type of utilisation do not lead to hazards. The floor area of the installation must be of a design and size such that the fireplace can be operated properly and as intended.

UK - All stoves must be fitted in accordance with UK local building and HETAS regulations.

Appliances may only be commissioned by HETAS accredited installers. Only appliances registered with DEFRA may be installed in UK smoke controlled area.

### 2.1.1 INSTALLATION SITE

Your stove must not be installed:

1. In stairways, unless they are in residential buildings with two or fewer flats.
2. In hallways with general access.
3. In garages.
4. In rooms or flats that are ventilated through ventilation systems or warm air heating through the use of fans, unless the safe operation of the stove is ensured.
5. In rooms in which highly combustible or potentially explosive substances or mixtures are processed, stored or manufactured in quantities that would be hazardous in the event of ignition or explosion

### 2.1.2 MULTIPLE CONNECTION

Multiple connection of the chimney in accordance with DIN 18160 is possible as the stove has a self-closing combustion chamber door. Note that all fireplaces connected to the same chimney must also be approved for multiple connection.

## 2.2 TECHNICAL DATA

The following data have been taken from the test report and relate to test conditions.

Stove	a1/a2/a3/a4		a4 H <sub>2</sub> O		a5	a6	a6	a6 H <sub>2</sub> O	a6 H <sub>2</sub> O	a7	a8
	RLA (non-room air sealed operation)	RLU (room air sealed operation)	RLA (non-room air sealed operation)	RLU (room air sealed operation)	RLA (non-room air sealed operation)	RLA heat accumulator attachment	RLA convection air heating attachment	RLA (non-room air sealed operation) 7.9 kW	RLA (non-room air sealed operation) 11.0 kW (export only)	RLA (non-room air sealed operation)	RLA (non-room air sealed operation)
Fuel type	Firewood										
Nominal heat output (kW)	5.9	5.9	8.0	8.0	7.0	5.9	5.9	7.9	11.0	5.9	5.9
Thermal output range (kW)	4.5-7.7	4.5-7.7	5.6-10.4	5.6-10.4	4.9-9.1	4.5-7.7	4.5-7.7	5.5-10.3	7.7-14.3	4.5-7.7	4.5-7.7
Water heating capacity (kW)	-	-	5.2	5.2	-	-	-	4.9	6.8	-	-
Room heating capacity (kW)	-	-	2.8	2.8	-	-	-	3.0	4.2	-	-
Wood consumption (kg/h)	1.8	1.8	2.2	2.2	2.2	1.8	1.8	2.3	3.2	1.8	1.8
Efficiency (%)	> 80	> 80	> 88	> 88	> 78	>80	>80	>80	85	> 80	> 80
CO content 13% O <sub>2</sub> (mg/Nm <sup>3</sup> )	< 1250	< 1250	< 1250	< 1250	< 1250	<1250	<1250	<1250	<1250	< 1250	< 1250
Dust content (mg/Nm <sup>3</sup> )	< 40	< 40	< 40	< 40	< 40	< 40	< 40	< 40	< 40	< 40	< 40
Flue gas temperature at the connecting socket (°C)	350	350	150 <sup>1</sup>	150 <sup>1</sup>	305	317	317	238	249	318	300
Supply pressure (mbar*)	0.12	0.12	0.12	0.12	0.12	0.12	0.12	0.12	0.12	0.12	0.12
Mass flow of flue gas (g/s)	5.1	5.1	7.6	7.6	6.8	4.3	4.3	7.8	9.6	5.1	5.6
Combustion air requirement (m <sup>3</sup> /h)	17.5	17.5	26.1	26.1	23.5	17.5	17.5	24.6	31.6	17.8	20.6
Weight according to model (kg)	approx. 180-335	approx. 180-335	approx. 230	approx. 230	approx. 225 / 240 / 255	approx. 400-490	approx. 355-445	approx. 340-430	approx. 340-430	approx. 170-205	approx. 200-300
Permitted working overpressure (bar)	-	-	3.0	3.0	-	-	-	3.0	3.0	-	-
Maximum permitted flow temperature (°C)	-	-	105	105	-	-	-	105	105	-	-
Max. operating temperature (°C)	-	-	95	95	-	-	-	95	95	-	-
Minimum return temperature (°C)	-	-	60	60	-	-	-	60	60	-	-
Water-side resistance at 650 l/h (mbar)	-	-	26	26	-	-	-	22	22	-	-
Minimum throughput of thermal discharge safety device (litres)	-	-	900	900	-	-	-	900	900	-	-
Water content (litres)	-	-	approx. 29	approx. 29	-	-	-	approx. 29	approx. 29	-	-
Flow and return connection (IG)	-	-	¾"	¾"	-	-	-	¾"	¾"	-	-
Safety heat exchanger inlet and drain connection (IG)	-	-	½"	½"	-	-	-	½"	½"	-	-

\* Depending on the stove, negative pressures greater than 20-25 Pa can influence correct operation. The pane can become increasingly contaminated or noise can be intensified!

<sup>1</sup> Due to the low flue gas temperature of the ambiente a4 H<sub>2</sub>O, a suitable chimney system is required (not sensitive to moisture)!

Stove	a1/a2/a3/a4		a4 H <sub>2</sub> O		a5	a6	a6	a6 H <sub>2</sub> O	a6 H <sub>2</sub> O	a7	a8
	RLA (non-room air sealed operation)	RLU (room air sealed operation)	RLA (non-room air sealed operation)	RLU (room air sealed operation)	RLA (non-room air sealed operation)	RLA (non-room air sealed operation)	RLA convection air heating attachment	RLA (non-room air sealed operation) 7.9 kW	RLA (non-room air sealed operation) 11.0 kW (export only)	RLA (non-room air sealed operation)	RLA (non-room air sealed operation)
Requirements											
BlmSchV 1st and 2nd stage	Yes	Yes	Yes	Yes	Yes	Yes	Yes	Yes	Yes	Yes	Yes
EN 13240	Yes	Yes	Yes	Yes	Yes	Yes	Yes	Yes	Yes	Yes	Yes
DIN Plus	Yes	Yes	Yes	Yes	Yes	Yes	Yes	Yes	Yes	Yes	Yes
Regensburg municipal ordinance	Yes	Yes	Yes	Yes	Yes	Yes	Yes	Yes	Yes	Yes	Yes
Munich municipal ordinance	Yes	Yes	Yes	Yes	Yes	Yes	Yes	Yes	Yes	Yes	Yes
Aachen municipal ordinance	Yes	Yes	Yes	Yes	Yes	Yes	Yes	Yes	Yes	Yes	Yes
15a (for Austria)	Yes	Yes	Yes	Yes	<b>No</b>	Yes	Yes	Yes	Yes	Yes	Yes
Clean Air Ordinance from 01/2011 (for Switzerland)	Yes	Yes	Yes	Yes	Yes	Yes	Yes	Yes	Yes	Yes	Yes

## 2.3 INSTALLATION / ASSEMBLY

Your stove may only be set up on floors with sufficient load-bearing capacity. Please note the overall weight (see technical data). If necessary, load-bearing capacity must be ensured by placing the stove on top of a slab of non-combustible building material of sufficient thickness for weight distribution purposes.

Stand the stove on the floor and level it horizontally, observing the safety distances (refer to „2.5 Fire protection“ on page 19). The legs are height-adjustable.

When selecting the installation site, also note the necessary measures for fire protection (see page 19 Fire protection).

Install the stove using the flue tube elbow set available from us; you will find the connection height dimensions for your specific stove below.

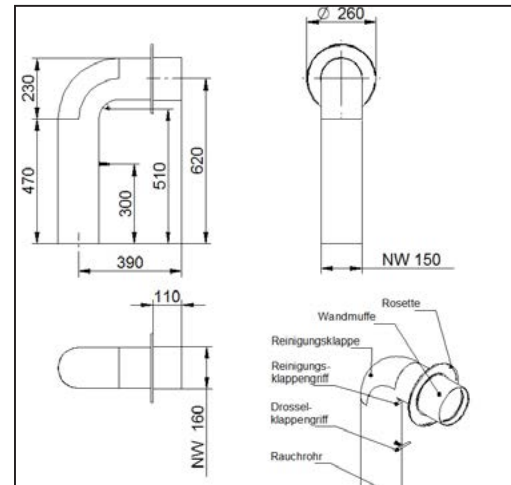

Fig. 1a



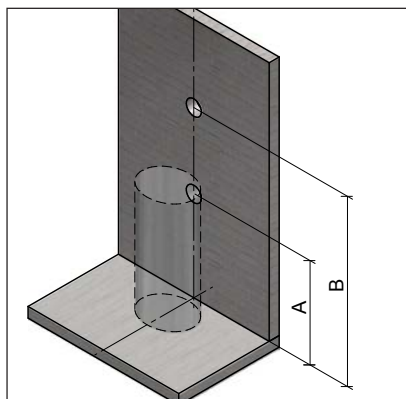

Fig. 1b

**Dimension B:** Flue tube connection height with rear outlet

**Dimension C:** Flue tube connection height when using the flue tube elbow set

Stove	Bore dia. 150 mm	
	A in mm	B in mm
ambiente a1 / RLU	1025	1764
ambiente a2 / RLU	1025	1764
ambiente a3 / RLU	1145	1884
ambiente a4 / RLU	not possible	
ambiente a4 H <sub>2</sub> O / RLU	1541	2257
ambiente a5	1124	1855
ambiente a6 heat accumulator attachment	1306	2042
ambiente a6 convection air attachment	1306	2042
ambiente a6 H <sub>2</sub> O	1308	2048
ambiente a7	985	1756
ambiente a8	-	1756

## 2.3.1 CHANGING THE FLUE GAS CONNECTION DIRECTION

Upon delivery, the stove is set up for rear flue gas connection provided no other details are given. If the position of the flue gas connection is changed, the following assembly steps must be performed:

### Changing the flue gas connection direction from the rear to the top: ambiente a1/a2/a3/a4/a4 H<sub>2</sub>O/RLU

**Assembly from the rear to the top:** If the chimney connecting piece is already assembled, this must be removed (Fig. **2a** point A). Remove the top cover lid and the cover lid for the top flue gas connection (Fig. **2a** point B). Undo the screws and remove the cover plate (Fig. **2b** point B and C). Then disassemble the pipe nozzle of the rear outlet. Firstly remove the screws (Fig. **2b** point D). Assemble the pipe nozzle on the top flue gas connection (Fig. 2c point E and F). Then assemble the cover plate on the rear flue gas connection (Fig. **2d** point E and F). Finally fit the cover lid for the rear flue gas connection (chimney connecting piece) and reposition the cover lid (Fig. **2e** point E and G). Suitable storage stones can be fitted at the rear on the ambiente a4 (see point 2.3.3. Assembly of the heat storage mass).

**Assembly from the top to the rear:** If the chimney connecting piece is already assembled, please remove (Fig. **2f** point A). Remove the top cover lid and the cover lid for the rear flue gas connection (Fig. **2f** point B). Undo the screws and remove the cover plate (Fig. **2g** point B and C). Then disassemble the pipe nozzle of the top outlet. Firstly remove the screws (Fig. **2h** point C and D). Assemble the pipe nozzle on the rear flue gas connection (Fig. 2i point E). Then assemble the cover plate on the top flue gas connection (Fig. **2i** point E and G). Finally fit the cover lid for the top flue gas connection (chimney connecting piece) and reposition the cover lid (Fig. **2j** point E and G).

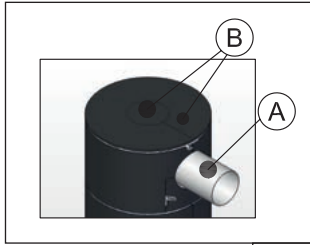

Fig. 2a

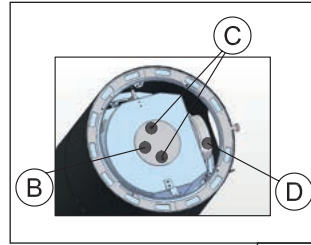

Fig. 2b

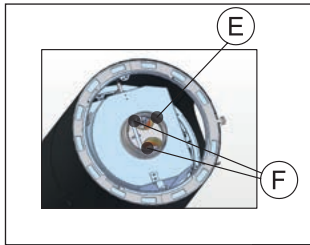

Fig. 2c

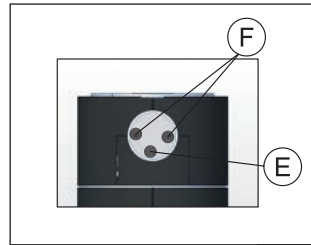

Fig. 2d

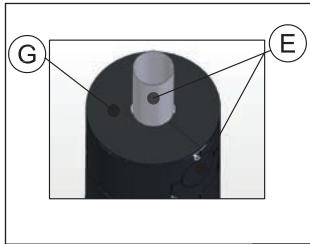

Fig. 2e

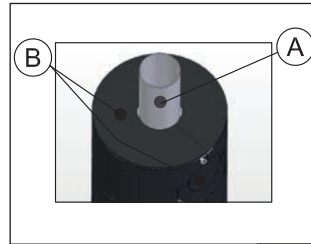

Fig. 2f

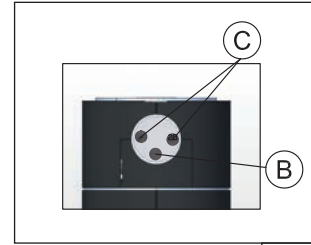

Fig. 2g

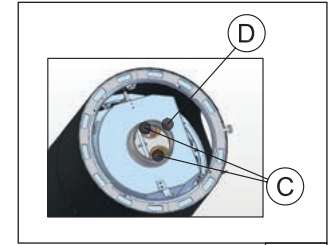

Fig. 2h

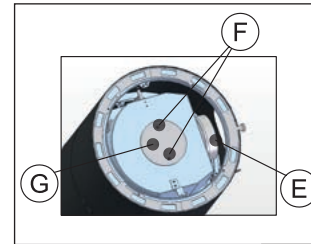

Fig. 2i

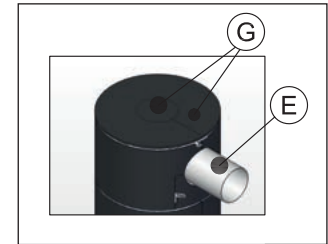

Fig. 2j

A	remove
B	take off
C	loosen

D	disassemble
E	assemble

F	secure
G	attach

**Note:** With the ambiente a4/a4 RLU when the connection is changed, the rear lower storage stones must be replaced by the small storage stone (order no.: 1013340) (see Fig. 6c, 6d). A separate flue tube elbow must also be ordered for this stove dia. 150 mm (order no. 1013833).

### ambiente a5

**Assembly from the rear to the top:** If the chimney connecting piece is already assembled, please remove (Fig. 3a). Remove the two cover lids at the top (Fig. 3a). Undo the hexagonal bolts and remove the cover plate (Fig. 3b). Then disassemble the pipe nozzle of the rear outlet, to this end undo the screws (Fig. 3b). Assemble the pipe nozzle on the top flue gas connection (Fig. 3c). Then assemble the cover plate on the rear flue gas connection (Fig. 3c). Finally reassemble the cover lid for the rear flue connection, the chimney connecting piece and the cover plate (Fig. 3d).

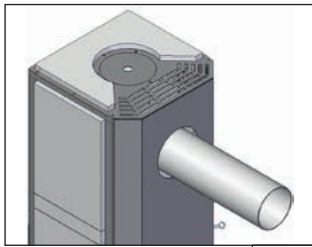

Fig. 3a

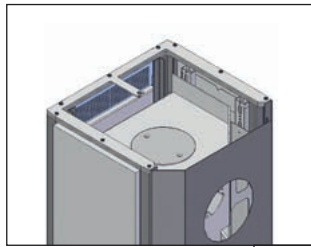

Fig. 3b

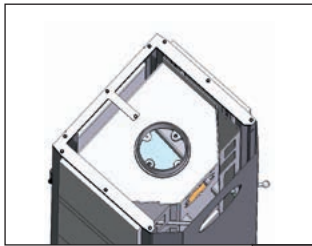

Fig. 3c

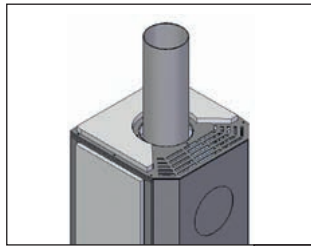

Fig. 3d

### ambiente a6/a6 H<sub>2</sub>O/a7/a8

The ambiente a8 is a tunnel stove with two combustion chamber doors. The stove has a flue gas nozzle connection at the top. The direction of the flue gas connection cannot be changed.

**Assembly from the rear to the top:** If the chimney connecting piece is already assembled, please remove. Remove the top cover lid and the cover lid for the top flue gas connection (Fig. 4a). Then disassemble the pipe nozzle of the rear outlet. Firstly undo the screws (Fig. 4a). Undo the screws and remove the cover plate (Fig. 4b). Assemble the pipe nozzle on the top flue gas connection (Fig. 4c). Then assemble the cover plate on the rear flue gas connection (Fig. 4c). Finally put the cover lid back in place (Fig. 4d).

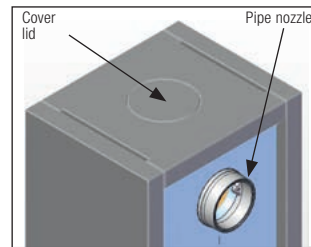

Fig. 4a

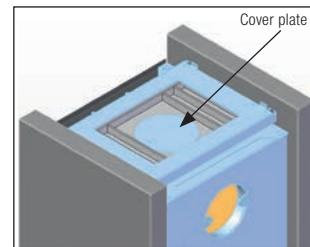

Fig. 4b

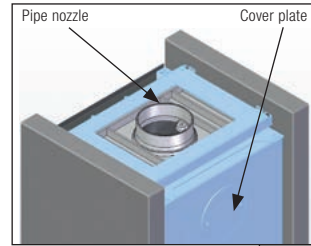

Fig. 4c

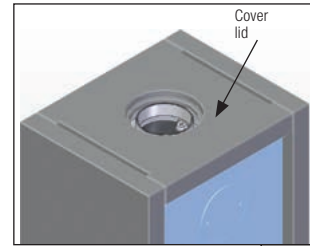

Fig. 4d

## 2.3.2 ASSEMBLY OF THE FACEPLATE ON THE ROTARY BASE

### ambiente a1/a2/a3/a4

The faceplate is located on top of the appliance upon delivery. The faceplate should not be fitted until the stove has reached its installation location and has been levelled. Be sure to unscrew the legs by a distance of 6-14 mm (Fig. 5a). Next, undo the two fastening screws on the rear of the faceplate (Fig. 5b) point B.

Now fit the faceplate around the rotary base. The faceplate has to be pulled apart at the join to do this. After placing the faceplate in position, re-insert the two screws at the join (Fig. 5b). Then screw the faceplate on to the retainers provided (Fig. 5c).

Functioning of the rotary base is described under „3.3 Functioning of the rotary base“ on page 32.

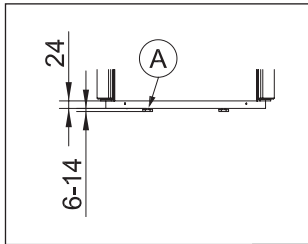

Fig. 5a

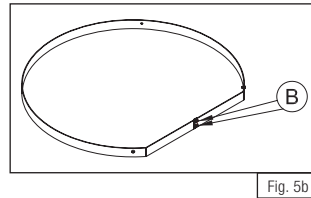

Fig. 5b

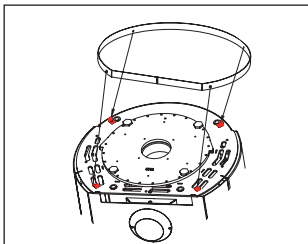

Fig. 5c

A	Faceplate
B	Undo screws

## 2.3.3 ASSEMBLY OF THE HEAT STORAGE MASS

### ambiente a3/a3 RLU/a4/a4 RLU

Storage stones can only be fitted or retrofitted to the ambiente a3 and a4 models.

If the ambiente a3 or a4 is ordered with storage stones, the front stone and supporting plate are already fitted at the factory. For weight reasons, the other storage stones are assembled on site. Stoves are supplied with a rear flue gas connection as standard, unless otherwise specified at the time of ordering.

To install the storage stones, start by removing the cover. Note that the stove should not yet be connected to the chimney when doing this.

### Fitting the front stone:

(Only if retro fitting storage stones). Firstly fit the front stone (A). Next, fit the supporting plate (B) (Fig. 6a).

### Fitting the storage stones:

#### ambiente a3 with top and side flue gas connection:

Place the three shallow stones in position to form a ring and replace the cover (Fig. 6b).

A	Front stone
B	Supporting plate
C	Convective heat to room
D	Pipe nozzle
E	Lid
F	Convection air adjustment lever

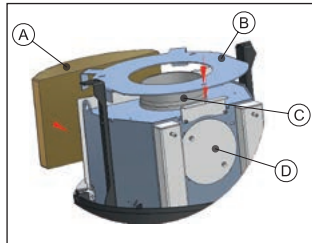

Fig. 6a

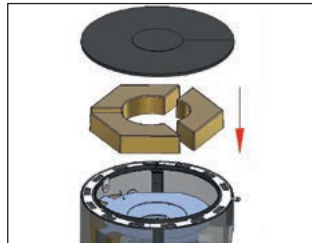

Fig. 6b

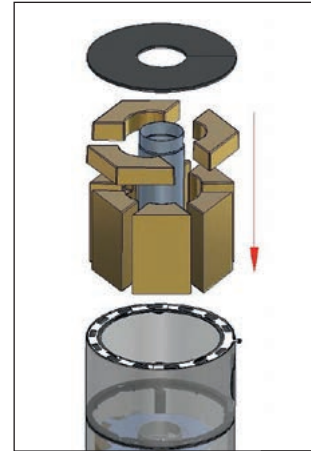

Fig. 6c

#### ambiente a4 with top flue gas connection:

Start by placing the six tall stones in position to form a ring. These have a recessed handle on the inside to facilitate assembly. Now place the three shallow stones in position to form a ring and replace the lid (Fig. 6c).

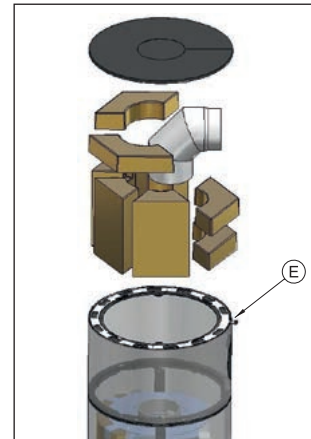

Fig. 6d

#### ambiente a4 with side flue gas connection:

Start by placing the two small stones under the flue gas elbow pipe, and then place the four tall stones in position. These have a recessed handle on the inside to facilitate assembly. Now place the two shallow stones in position and replace the lid (Fig. 6d)

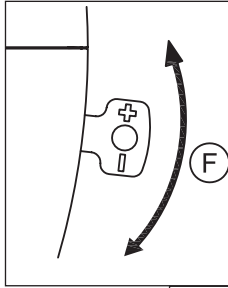

Fig. 6e

### Controlling the heat output to the storage system:

(ambiente a3 and a4)

The heat output to the storage stones can be controlled via the adjustment lever (Fig. 6e). If the adjustment lever is moved to the '+' position, the convective heat is transmitted directly from the stove to the room. The room will warm up faster at this setting. If the adjustment lever is set to the '-' position, the convective heat will remain in the storage stones for longer.

The heat is stored in the stove and slowly released to the room after the fire has gone out. The stove will continue to provide a cosy warmth even when the fire has gone out.

### ambiente a5

The ambiente a5 stove can be optionally fitted with storage stones for prolonged heat storage. Proceed as follows to fit the stones: In order to fit storage stones to the ambiente a5 stove, the first step is to remove the stove top lid (Fig. 7a).

Now push the 'front' storage stone (WxHxD 310 mm x 285 mm x 30 mm) into the front locating slot (Fig. 7b). Next, place the two 'back' storage stones (WxHxD 250 mm x 390 mm x 30 mm) in the locating slot at the rear of the body (Fig. 7c). Place the 'top' storage stones (Fig. 7d - 7h) on the top plate of the stove body, according to whether the stove has a top or rear flue gas connection. This example shows a rear flue gas connection. After putting the storage stones in position, replace the stove top lid (Fig. 7i - 7j).

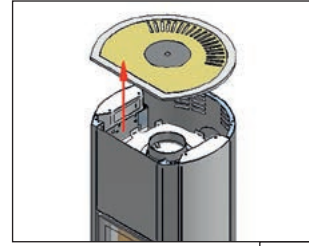

Fig. 7a

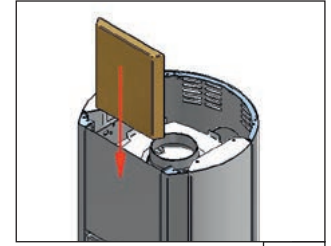

Fig. 7b

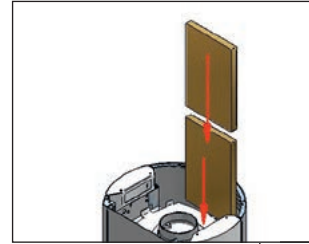

Fig. 7c

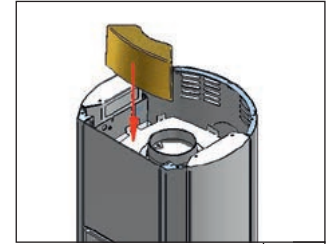

Fig. 7d

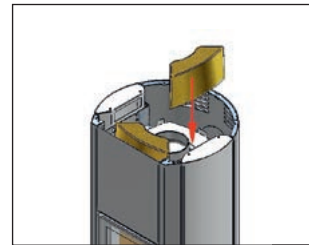

Fig. 7e

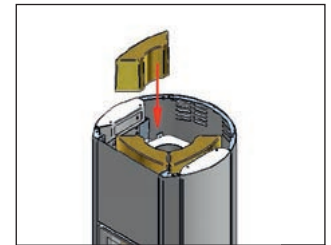

Fig. 7f

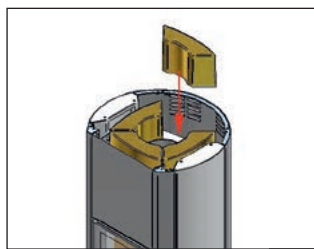

Fig. 7g

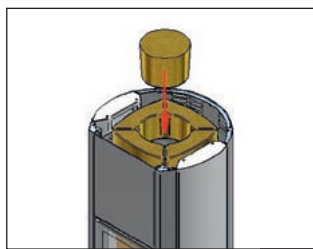

Fig. 7h

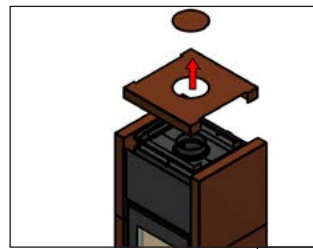

Fig. 8a

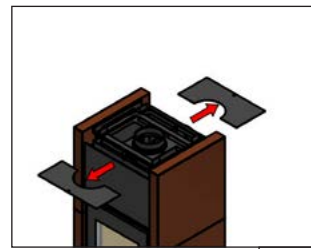

Fig. 8b

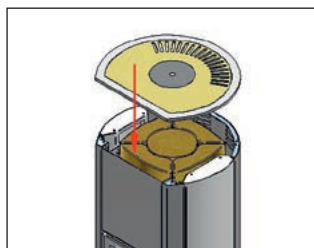

Fig. 7i

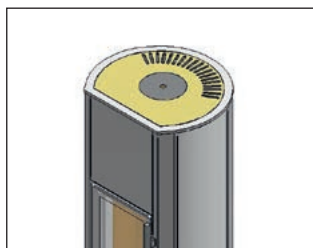

Fig. 7j

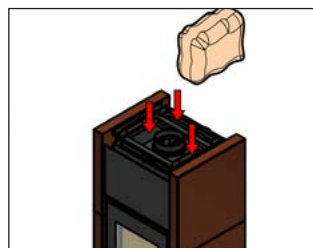

Fig. 8c

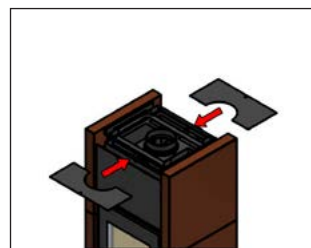

Fig. 8d

### **ambiente a6 with heat accumulator attachment:**

The Magnatherm storage stone filling is supplied separately with the ambiente a6 with a heat accumulator attachment for weight reasons. To fill the heat storage mass firstly remove the top lid of the stove and then the two attachment lids. Then slowly and carefully fill the Magnatherm filling in the heat accumulator attachment. It must be ensured that no stones are in the central flue dome! Upon completion, replace both attachment lids and the top plate.

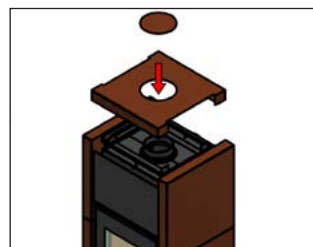

Fig. 8e



Fig. 8f

## 2.4 COMBUSTION AIR SUPPLY

The combustion air supply can be provided in various ways as described in sections 2.4.1 Non-room air sealed operation (RLA), 2.4.2 Room air sealed operation (RLU) and 2.4.3 Separate combustion air supply.

### 2.4.1 NON-ROOM AIR SEALED OPERATION (RLA)

Your ambiente a1/a2/a3/a4/a4H<sub>2</sub>O/a5/a6/a6 H<sub>2</sub>O/a7/a8 stove draws the air it needs for combustion from the room where it is installed (non-room air sealed operation). An adequate supply of fresh air must be ensured in the room where the stove is installed (for further details refer to the heating systems regulations for the country concerned, DIN 18896, the technical rules, etc.). The fresh air supply must be checked by the installer and the operator. When operating several fireplaces in a single room or linked space, ensure that sufficient air is available for complete combustion! It is possible that there is not a sufficient supply of fresh air if the windows and doors are sealed (e.g., in combination with energy saving measures). As a result, the ventilation of the stove can be affected. This can adversely affect your well-being and, potentially, your safety. If necessary, an additional air supply can be provided by fitting an air inlet near the stove or by fitting a combustion air intake pipe which connects with the external air (see page 16), or with a well ventilated room (not the room where the stove is installed). In particular, ensure that the necessary combustion air pipes are open during the operation of the fireplace insert. Simultaneous operation with a ventilation system (e.g. extractor hood, bathroom fan, etc.) in the same room or connected space can adversely affect the function of the fireplace (to the point of smoke or flue gas accumulating in the living room, despite the combustion chamber door being closed). It is therefore prohibited to operate appliances of this kind simultaneously with a stove without first taking appropriate precautionary measures.

### 2.4.2 ROOM AIR SEALED OPERATION (RLU)

The RLU stoves have been developed for combination with domestic ventilation systems for a vacuum of up to 8 Pa in the room in which they are installed and can be operated without additional safety measures. For room air sealed operation the combustion air must be guided via tight lines from outside or conveyed to the system via an air-exhaust system. To this end, the combustion air channel must be permanently tightly connected to the combustion air nozzle (rear/side/bottom connection) of the stove.

Upon connecting a RLU stove to the combustion air line, the information from the German Association of Stove and Hot-Air Heating Systems (TROL technical rules), DIN 18896 etc. must be observed. Sufficient dimensioning in particular must be ensured.

Country-specific and local fire safety regulations must be observed! Make sure that the pipelines are always tight.

### 2.4.3 SEPARATE COMBUSTION AIR SUPPLY

It is possible to provide the stove with a separate combustion air supply. The separate combustion air connection is located at the rear of the appliance or below it. The nozzle is ready-assembled. The stove covering can be opened up for the purpose. When connecting a pipe connection to the combustion air connection nozzle, the combustion air is supplied to the stove from outside or from other rooms, e.g., the cellar. When connecting up the stove to a combustion air pipe, the requirements of TROL (technical rules), DIN 18896, etc. must be observed and applied.

**In particular, sufficient dimensioning of the pipes must be ensured! If using a rotary base, a permanently flexible connection must be made! The rotating action must not be restricted.**



Combustion air intakes and pipes must not be obstructed or closed unless special safety devices are fitted to ensure that the stove can only be operated when the closing system is open. The cross-section must **not** be narrowed by a fastening or a grille. This measure is not necessary with air/exhaust chimneys. If the combustion air pipe has to be routed out of the building, a shut-off device must be fitted. The position of the shut-off device must be identifiable from outside. In the case of an external connection the pipe should be insulated, as condensate may form. Also, when fitting the pipe it should be ensured that no water or other substances can enter the stove and that any condensate can drain away outside.

According to the relevant provisions, combustion air lines that bridge firewalls in buildings with more than two full storeys must be constructed such that fire and smoke cannot spread to other storeys or fire lobbies. Country-specific and local fire safety regulations must be observed!

#### **Special instructions for the ambiente a1 and a2**

With a combustion air connection with SQC (Spartherm Quick Coupling), the stove is to be connected as follows.

The stove installation site must be fitted with a supply channel / bore as per the technical instructions. When mounted directly on the wall, the combustion air and flue gas connection must be level. The stove is supplied with the mounted SQC and turned out feet. In this state, the nozzle is in the air and not in contact with the floor. As such, the stove can be transported with the usual aids (e.g., hand truck).

#### **Example using ambiente a1:**

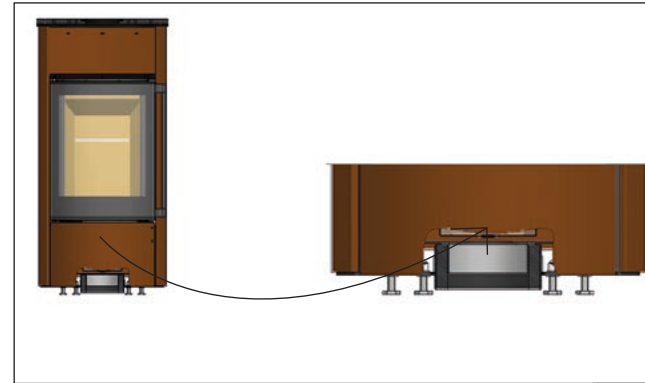

(Fig.: Transport position with SQC)

Fig. 9a

### Assembly sequence

1. Position the stove in its final position with the legs turned out.

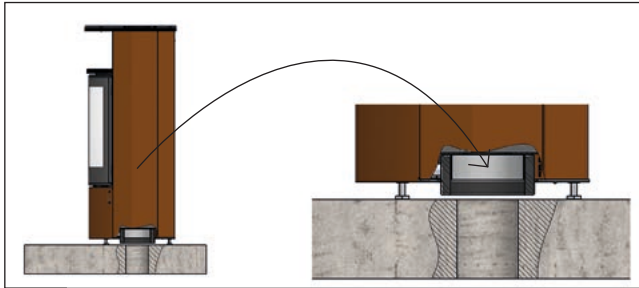

Fig. 9b

(Fig.: Installing the stove with SQC)

2. Turn in the feet to set the stove to its nominal height. Upon lowering, the SQC nozzle comes into contact with the installation floor and surrounds the on-site supply section.

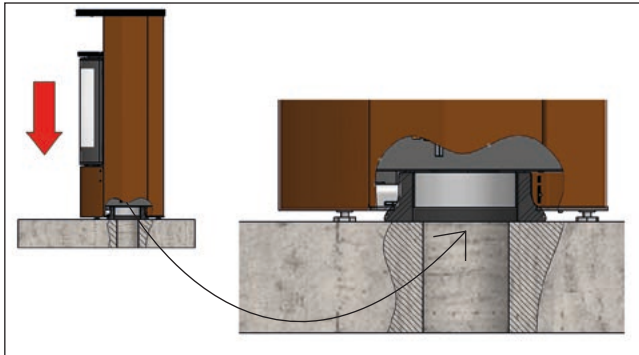

Fig. 9c

(Fig.: Installing the stove with SQC)

### Connection dimensions of a stove with SQC

**Dimension A and B** see point „2.3 Installation / assembly“ on page 8.

#### Dimension C

Distance from installation wall to middle of air supply bore. Note the clearance of the flue tube connection on the chimney!

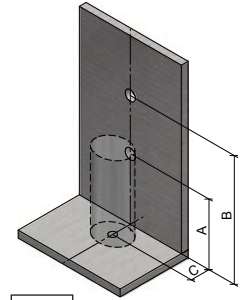

Fig. 9d

(Fig.: Connection dimensions for SQC and flue tube elbow set)

Stove	Date built	Order no.	C in mm Bore dia. 100 mm	
			with combustible mounting wall	with mounting wall which does not require protection
ambiente a1	as of 11/2014	1033725	303	253
ambiente a2		1033725	303	253

#### Special instructions for the ambiente a7/a8

It is possible to provide the stoves with a separate combustion air supply. The separate combustion air connection is located at the rear of the stove (a7 only) and on the underside of the stove (dia. = 100 mm). Proceed as follows to connect up the combustion air supply.

### Installation on underside of stove for a7 and a8:

Stand the stove on the floor above the combustion air connection. Now carefully lift off the stove covering. (Fig. 10a). Next, unscrew the screw cap. (Fig. 10b). Connect the combustion air nozzle to the flexible, extensible combustion air line installed on site. If the combustion air connection is rigid at floor level, the separate combustion air nozzle supplied must be pushed into the connection to form an airtight seal.



Fig. 10a

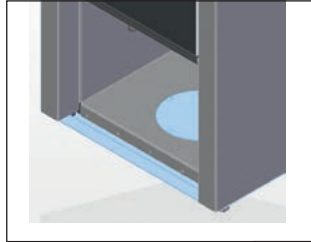

Fig. 10b

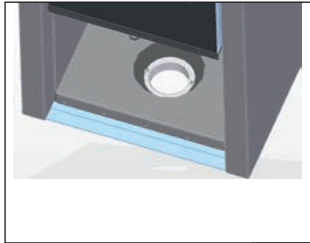

Fig. 10c

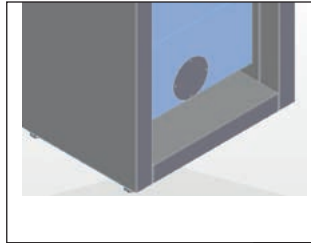

Fig. 10d

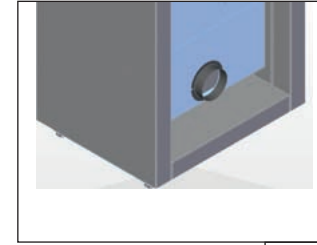

Fig. 10e

### Installation at rear of stove for a7:

Start by unscrewing the screw cap (Fig. 10c). Now fit the combustion air nozzle (Fig. 10d). Lastly, connect the combustion air nozzle with the combustion air line.

## 2.5 FIRE PROTECTION

### General information about fire protection

Stoves are heating systems and are subject to regulations and essential fire precautions. The fire precautions and minimum distances should be borne in mind when selecting the installation location for the stove. **A minimum distance of 5 cm from the rear wall must always be maintained. Greater distances should be allowed for reasons of safety and fire prevention in the case of walls that need to be protected or combustible building components.**

The table that follows shows the distances that must be maintained according to the type of stove and the installation situation on site. Use the drawings (Figs. 12-14) to help you determine your particular installation situation and note the distances that must be maintained.

**Note the fire precautions when installing the stove. Ask your local chimney sweep for advice.**

- Their structure and materials enable non-combustible mounting walls not in need of protection to be permanently exposed to temperatures above 85°C.
- Combustible mounting walls in need of protection (e.g. stud partition construction) must be protected from temperatures above 85°C.

The mounting walls should be assessed before installing the stove. If the nature of the mounting wall cannot be identified with certainty, a specialist (such as the chimney sweep) should be consulted.

- According to DIN 4102-1, wallpaper used as a wall covering is not considered a combustible building component and does not require any special precautions. Please note that the underlying structure of wallpaper (e.g., stud partition construction) may well be combustible or in need of protection and the relevant precautions must be taken.
- Please note that the minimum distances indicated from rear walls and side walls need to be adapted for rotating stoves.
- It is important to observe the minimum distance from the chimney connecting piece to combustible building components („2.7 Connecting pieces“ on page 22).
- There must be no combustible objects within a radius of 50 cm above the stove.

### Floor coverings near the stove

Floors made from combustible materials in front of the combustion chamber door must be protected by a covering of non-combustible materials. This covering should extend at least 50 cm in front of the stove and at least 30 cm at each side (Figs. 12-14 point D) (measuring from the combustion chamber door or viewing pane).

No combustible objects (furniture, curtains, decorations, etc.) may be placed within the area of direct radiant heat of the combustion chamber door or inspection glass. That distance can be reduced to 40 cm if a fire screen ventilated on both sides is placed between the fireplace and any combustible objects.

### Determining the radiation area

To determine the radiation area of the stove, place a measuring device (yard stick, measuring tape) on the surface of the front pane and measure the central point of the stove past the door pillar. There must be no combustible components or components in need of protection in the resulting angle and within the side clearance.

### Minimum distances from nearby building components

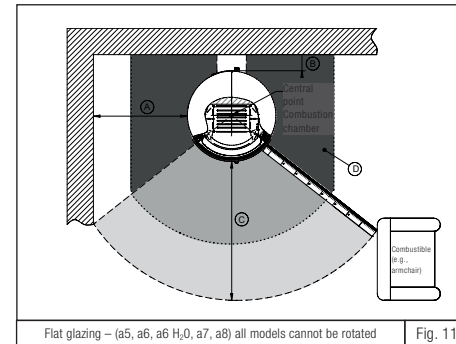

The distances indicated in the table below must be observed, according to your stove's viewing pane arrangement (see sketches below) and the nature of the mounting walls. In the stove installation example shown in Fig. 12-14 if dimension B is observed and dimension E measured on site is less than the value indicated, then it is not necessary to allow for the radiant area with respect to the side walls. However, if the side wall is longer than dimension E, it must be decided on site whether this wall needs to be protected. The position of the radiant area can be altered if necessary by increasing dimension A or dimension B. The handover inspection of your stove before commissioning is performed by the chimney sweep responsible. The chimney sweep can/should also advise prior to installation about installation conditions on site, and can provide advice on how to install the stove properly.

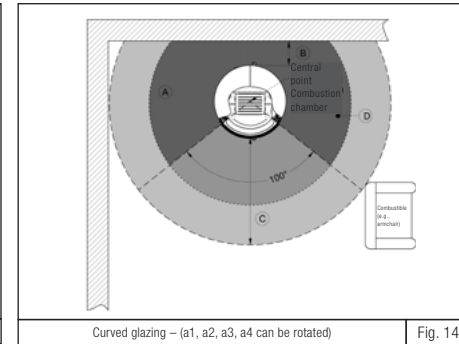
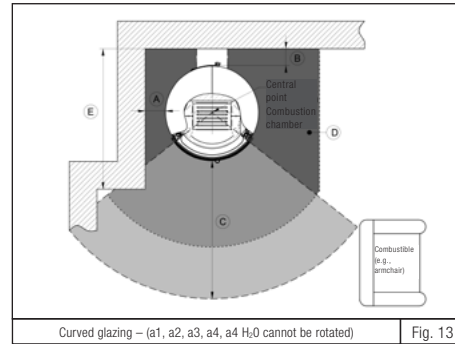
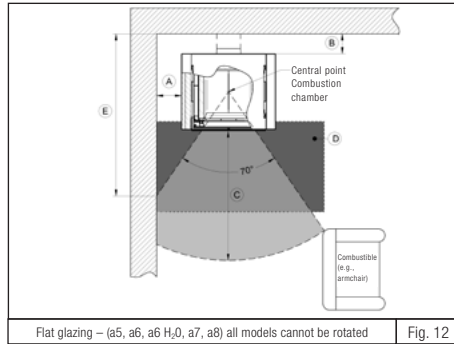

Stoves	Distance to side wall		Distance to rear wall		Distance in the area of radiant heat of pane(s)		Dimensions of fire protection flooring		Distance for radiant heat protection area
	A (cm)		B (cm)		C (cm)		D (cm)		
	combustible	not to be protected	combustible	not to be protected	combustible	not to be protected	length x width	Distance (with round flooring)	E (cm)
ambiente a1/RLU	15	10	10	5	80	80	50 x 30	50	66
ambiente a2/RLU	15	10	10	5	80	80	50 x 30	50	66
ambiente a3/RLU	15	10	10	5	80	80	50 x 30	50	66
ambiente a4/RLU	15	10	10	5	80	80	50 x 30	50	66
ambiente a4 H <sub>2</sub> O/RLU	10	10	5	5	80	80	50 x 30	50	66
ambiente a5	20	10	28	5	80	80	50 x 30	50	66
ambiente a6	15	10	10	5	80	80	50x30	50	88
ambiente a6 H <sub>2</sub> O	8	5	9	5	80	80	50x30	50	88
ambiente a7	15	10	15	5	70	70	50 x 30	50	100
ambiente a8	10	10	-	5	65	65	50 x 30	50	100

## 2.6 SHUT-OFF DEVICES

Flue gas systems must be created as per the technical rules of the German Association of Stove and Hot-Air Heating Systems (TROL). Stoves may have a shut-off device in the vent. These devices must not be self-closing and must not be positioned such as to prevent or hinder the inspection and cleaning of connecting pipework. The position of the shut-off device must be visible from the outside, e.g., from the position of the operating handle. Shut-off devices may only be installed in the exhaust manifold or collecting pipe, the flue gas pipe stub or the pipeline connecting piece.

## 2.7 CONNECTING PIECES

Your stove is connected to the chimney by 150 or 160 mm diameter connecting pieces made from steel sheet at least 2 mm thick. These must comply with DIN 1298 or DIN EN 1856-2 and they must be connected to the chimney in accordance with DIN 18160 or the regulations that apply in the country concerned.

It is important to ensure that the flue gas pipe takes the shortest possible route upwards towards the chimney. The number of bends in the flue gas pipe should be kept to a minimum. Ensure that the flue is stable/robust; where appropriate, the flue may need to be secured with brackets. If the flue leads through a combustible wall or is located close to any combustible components, the flue is to be insulated according to the respective regulations.

The connecting line must always be mounted in such a manner that it is possible to clean the connecting line at any time. This must be ensured through a sufficient number of cleaning openings.

If the ambiente a1/a2/a3/a4 RLA is designed to rotate, the connecting piping should be installed in such a way that the fastening is not compromised. The flue gas pipe must not turn when the stove rotates. Depending on the information provided by the flue gas pipe manufacturer, the minimum distance from the chimney connecting piece

to combustible components may increase the distance between the stove and combustible building components. The minimum distances from combustible components stated in this Manual refer to the stove, and should be adapted if necessary (see „2.5 Fire protection“ on page 19).

In the case of top flue gas routing, please note that a cleaning hatch must be provided above the flue gas nozzle.

## 2.8 INSTALLATION OF THE WATER-BEARING COMPONENTS OF THE AMBIENTE A4 H<sub>2</sub>O / a6 H<sub>2</sub>O

Installation of the water-bearing components, including fitting the necessary safety devices, temperature sensors and similar components should always be carried out by a specialist. The ambiente a4 H<sub>2</sub>O and a6 H<sub>2</sub>O should be installed in such a way that all water-bearing components are always accessible and can be inspected at any time

Note: The stove and all associated thermowells, connections, structural parts and piping must be hydraulic pressure tested and checked for leaks before commissioning.

## 2.8.1 AMBIENTE a4 H<sub>2</sub>O / a6 H<sub>2</sub>O CONNECTIONS

The connections are on the the rear, inside or underside of the stove (Fig. 15a - 15c and 16a - 16c).

### a4 H<sub>2</sub>O/ a4 H<sub>2</sub>O RLU

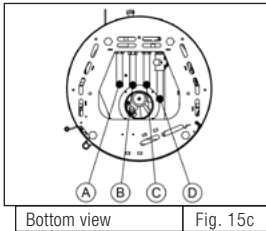
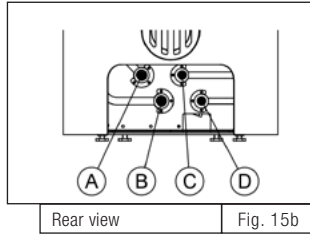
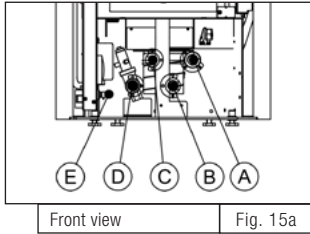

A	Return 3/4" internal thread
B	Flow 3/4" internal thread
C	Safety heat exchanger drain 1/2" internal thread
D	Safety heat exchanger inlet 1/2" internal thread
E	Vent valve 3/8"

### a6 H<sub>2</sub>O

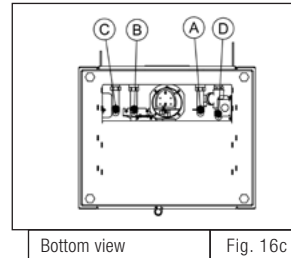
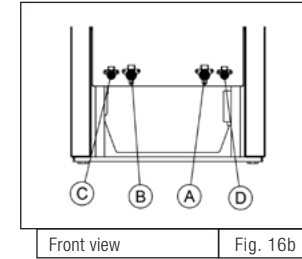
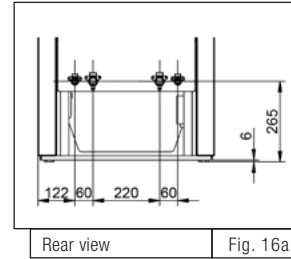

A	Return 3/4" internal thread
B	Flow 3/4" internal thread
C	Safety heat exchanger drain 1/2" internal thread
D	Safety heat exchanger inlet 1/2" internal thread
E	Vent valve 3/8"

To facilitate installation of piping, etc., when making a connection through

the floor, at our homepage [www.spartherm.com](http://www.spartherm.com) The connections are fitted with protective caps and brass plugs for transport. This must be removed prior to installation.

The connections are labelled and must not be used for other purposes! In particular, the integral safety device (safety heat exchanger) should not be used to heat water. an installation template can be downloaded from the dealer login section. **The installation template is only valid in combination with the flexible connection kit!** Alternatively, we can supply a

paper print-out of a 1:1 scale installation template on request stating order number 1019193 for the a4 H<sub>2</sub>O/RLU and 1041864 for the a6 H<sub>2</sub>O. For straightforward, speedy connection of the pipework through the floor and the internal connections, the flexible connection kit for ambiente a4 H<sub>2</sub>O/ ambiente a4 H<sub>2</sub>O RLU can be ordered quoting order no.: 1016990. The order no. for the connection set for the ambiente a6 H<sub>2</sub>O is 1041862.

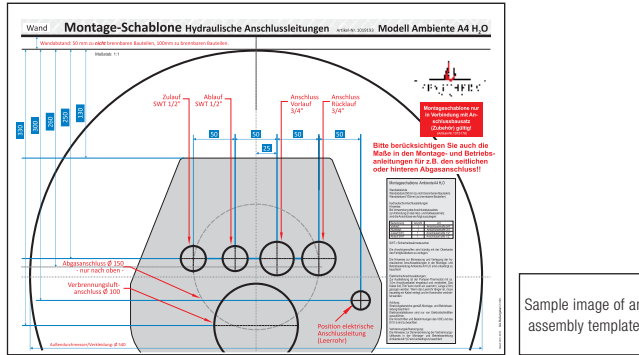

Sample image of an assembly template

## 2.8.2 BASIC REQUIREMENTS FOR INSTALLATION

The ambiente a4H<sub>2</sub>O/a6 H<sub>2</sub>O should only be installed in systems with a thermostatic safety device to DIN 4751 or DIN EN 12828. The connecting pipes to the heating system should always be laid in such a way that they can be disconnected (e.g. screwed connection).

Before using the stove for the first time, both the heating components (heating system) and the water components (thermal discharge safety device, safety heat exchanger) must be filled and vented. After the filling process, check all hydraulic connections for leaks.

### Operation without a water-side connection results in irreparable damage and invalidates any warranty claims!

A type-tested safety valve (coded H) with a threshold pressure of max. 3.0 bar should be fitted in the flow pipe immediately next to the a4H<sub>2</sub>O/a6 H<sub>2</sub>O. No shut-off devices must be integrated into the system between the safety valve and the ambiente a4H<sub>2</sub>O/a6 H<sub>2</sub>O. This could render the safety device inoperable. Moreover, all necessary safety devices must be integrated in the entire system in such a manner that safe operation is ensured. A separate safety valve must also be installed, if such a safety valve is installed at a different point in the entire system (comply with TRD 721!).

The installation and operating instructions for the heating components / additional components included in the system must be read and observed when installing the stove!

## 2.8.3 THERMAL DISCHARGE SAFETY DEVICE (TDS)

As the ambiente a4H<sub>2</sub>O/a6 H<sub>2</sub>O heating system cannot be quickly switched off automatically, the water heat exchanger must be fitted with a thermal discharge safety device according to DIN 4751 Part 2 or DIN EN 12828. A safety device (safety heat exchanger) to prevent overheating is integrated into the ambiente a4H<sub>2</sub>O/a6 H<sub>2</sub>O for this purpose. This safety device must not be used to heat water.

The thermal discharge safety device is not pre-assembled to protect it during transport and installation. It will be found inside the firebox at delivery and should be fitted to the correspondingly labelled connection. After that, the capillary and adapter should be screwed on to the thermal discharge safety device. This has been tested and approved for a minimum water throughput of 900 L/h.

The following instructions must always be complied with for the installation, so



that the safety device can function:

- At the cold water inlet, a flow pressure of at least 2 bar must be available. This pressure must be constantly ensured. That means, for example, that a domestic water supply which is dependent on the mains voltage is not permissible.
- A minimum water flow of approx. 900 L/h must be ensured. It must not be possible to shut off this supply.
- It must be ensured that cold water (5-20°) is always available. That does not include the domestic water supply.
- The thermal discharge safety device integrated in the heating system will open the cold water inlet at a boiler temperature of approx. 95°C!

All safety-relevant components must be integrated in the system in such a manner that function and leak-tightness can be checked at any time. The discharge of the thermal discharge safety device must be designed in such a manner that a check (e.g. via a drain with siphon) can take place at any time.

The cold water pipe should be flushed through before first using the system. This will flush out any dirt that could interfere with the closing of the thermal discharge safety device. The instructions and information provided by the manufacturer of the thermal discharge safety device must be observed.

## 2.8.4 THERMAL PUMP CONTROL OF THE ambiente a4 H<sub>2</sub>O / a6 H<sub>2</sub>O

A thermostatic switch is located in the bottom compartment for optimum control of the circulating pump. This ensures that the circulating pump will start up only when the water reaches the specified temperature (>60°C). It is possible for the pump to be controlled via the boiler control system or similar devices if the switch-on temperature of the pump is between 60°C

and 68°C.

The maximum contact rating of the factory-fitted pump thermostat is approx. 16 (4) A with a 250 V AC system.

The thermostat is factory-set to a temperature of approx. 62°C. The circulating pump or the load unit will thus be switched on or off if the temperature reaches or drops below the specified water temperature of approx. 60°C in the ambiente a4 H<sub>2</sub>O's water heat exchanger. As an option, the temperature can be adjusted by the installation contractor if circumstances demand. This is done by removing the top cover, according to the thermostat version. The temperature range can be altered after removing the cover.

**Please note:** At water temperatures below 60°C there is a greater risk of falling below the dew point. This can cause tarry soot to form. Also, cleaning becomes necessary much more often. We therefore recommend setting the temperature at which the pump switches on to a minimum of 60°C and a maximum of 68°C.

## 2.8.5 ELECTRICAL CONNECTION

The entire electrical installation of the individual components of the heating system must only be executed by an authorised specialised company. All electrical installations are to be carried out as per the VDE regulations (e.g. VDE 0105, VDE 0116, VDE 0100, etc.) and the technical connection conditions of the local power company.

The only work required on the ambiente a4H<sub>2</sub>O/a6 H<sub>2</sub>O is the electrical installation of the thermostat for the temperature riser pump (see page 28) and connection to the domestic electricity supply. The temperature-resistant connecting lead is approx. 3.0 m long and is already connected up inside the thermostat.

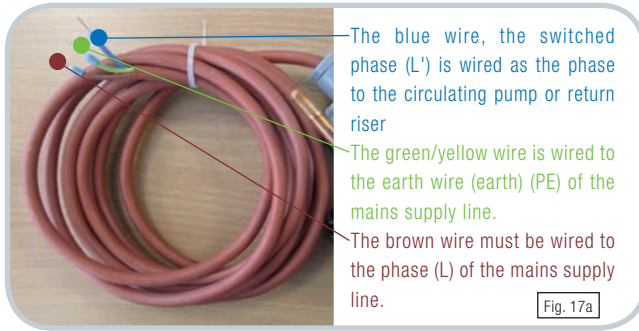

A	Electrical connection of pump control thermostat
B	Thermostat to control the pump (e.g. Afriso), with approx. 3.0 m connecting lead 2 x 0.75 mm <sup>2</sup>
C	Return flow temperature riser (circulating pump)
D	Terminal 1 not necessary!
E	Phase L (brown line)
F	Switched phase (L') blue lead

The functioning of the thermostatic switch can be checked before using it for the first time with hot water (e.g., from a kettle) and a thermometer. Note that the cover panel has to be removed in order to do this.

## 2.8.6 INTEGRATION IN A HEATING SYSTEM

Please note: The ambiente a4H<sub>2</sub>O/a6 H<sub>2</sub>O must only be installed in an overall system after detailed planning of the overall heating system in accordance with the relevant rules of technology and the safety standards. Proper configuration of the pumps, fittings, pipeline, buffer tank and the safety components, is the responsibility of the planning firm and/or of the company in charge of installation. For heating lines, we recommend a minimum nominal copper pipe diameter of 22 x 1.0 mm, or 3/4" for steel pipe. For cold water pipes a nominal pipe size (copper pipe) of 15x1.0 and a flow pressure of 2.0 bar are sufficient for safe operation. Possible variant for integration into a heating system.

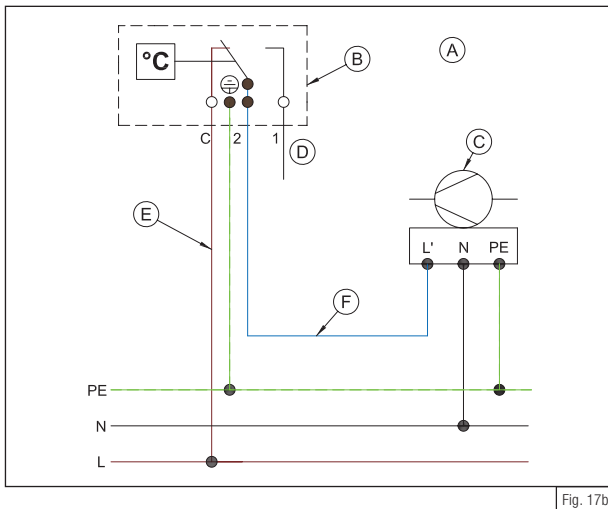

A	Temperature sensor for thermal discharge safety device ½" internal thread
B	Temperature sensor for thermostatic switch ½" internal thread
C	Return ¾" internal thread
D	Flow ¾" internal thread

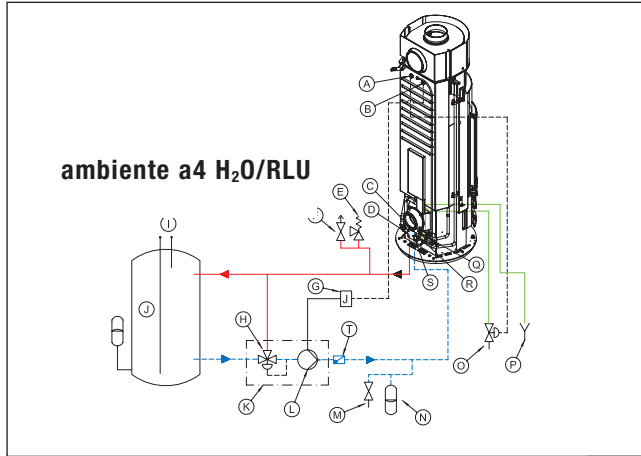

Fig. 18a

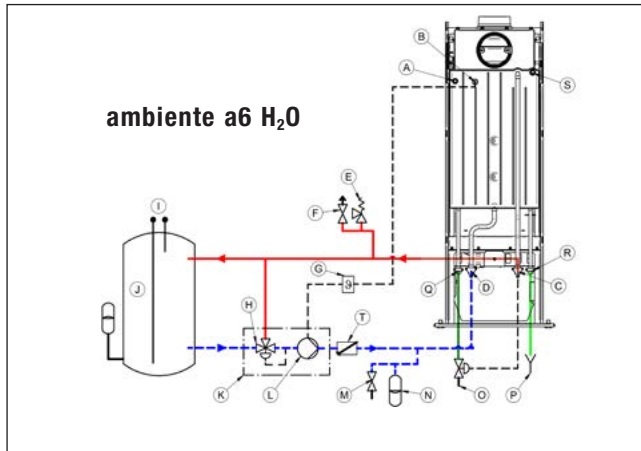

Fig. 18b

E	Safety valve 2.50 - 3.0 bar
F	Connecting pipe vent
G	Pump thermostatic switch (e.g. Afriso, GTK)
H	Thermostatic valve
I	Heating system hydraulic connection
J	Buffer tank
K	Return temperature riser (e.g. ESBE, model LTC 200)
L	Circulation pump
M	Filling and draining fitting
	Expansion tank
O	Thermal discharge safety device (e.g. Watts, STS 20/200)
P	Open drain, e.g. into wastewater system
Q	Safety heat exchanger drain ½" internal thread
R	Safety heat exchanger inlet ½" internal thread
S	Heat exchanger vent 3 /8"
D	Non-return valve

However, dimensioning of this pipework must be carried out by the specialist company in charge, taking due account of on-site conditions.

The ambiente a4H<sub>2</sub>O/a6 H<sub>2</sub>O can be integrated with reference to Figure 18a and 18b. A buffer tank must be included. The buffer tank volume should be calculated according to BImSchV 1 and 2. This specifies that at least 55 litres of buffer tank volume must be provided per kW water output.

For the ambiente a4H<sub>2</sub>O that means: 5.7 kW x 55L/kW = 341L.

For the ambiente a6 H<sub>2</sub>O that means: 4.9 kW x 55L/kW = 269 L.

As this is not a standard size available on the market, the next largest buffer tank with a capacity of 500 litres should be selected.

The following sample calculation can be helpful for dimensioning the buffer

tank:

The following assumptions have been made:

- Size of the buffer tank: 500 l (approx. 500 kg water)
- Initial water temperature in buffer tank: 40°C
- Final water temperature in buffer tank: 70°C
- Temperature differential 30°C (corresponds to 30 K)
- **No heat is drawn from the tank while it is being heated by the ambiente a4H<sub>2</sub>O/a6 H<sub>2</sub>O!**

Thus the heat required to heat 500 litres of water in a tank from 40°C to 70°C is 62,805 kJ (= 62,805 kWh) (disregarding any losses or heat drawn within the system). That corresponds to approx. 17.4 kWh.

Assuming that the ambiente a4 H<sub>2</sub>O has an average output of approx. 5.4 kW it will take about 3.2 hours to heat up the entire tank (500 L). This calculation is based on heating up the entire volume in the tank uniformly. In an efficiently designed heating system the hot water is stored in layers in the buffer tank, e.g. in a stratified storage system. That way, hot water is available after heating up for only a short time and heat is available for use shortly after circulation starts in the ambiente a4 H<sub>2</sub>O. Only surplus energy not needed for heating is then stored in the buffer tank.

On very cold winter days an ambiente a4 H<sub>2</sub>O may sometimes be in operation for about 12 hours. The quantity of heat thus produced then corresponds theoretically to 65 kWh. That quantity of heat would heat approx. 1,900 litres (from 40°C to 70°C). As a rule, though, heat is always drawn off in such a situation and so overheating of the buffer tank (> 90°C) will not occur.

$$Q = c_p \times m \times \Delta t$$

$$Q = 4,187 \frac{\text{kJ}}{\text{kg} \times \text{K}} \times 500 \text{ kg} \times 30 \text{ K}$$

$$Q = 62805 \text{ kJ}$$

## 2.8.7 RETURN FLOW TEMPERATURE RISER

As a general rule, the ambiente a4 H<sub>2</sub>O/a6 H<sub>2</sub>O may only be operated with a return flow temperature riser. In operation, the supply flow temperature should be at least 65°C and the return temperature at least 60°C. In order to ensure that these temperatures are guaranteed, a circulation pump / return flow temperature riser are to be installed in such a way that they will only start-up when the temperature has reached 62°C. To reduce the danger of overshooting the dew point, a “controllable” return flow riser is generally to be installed. This involves capturing the control variable, which corresponds to the effective return temperature at the entry to the water heat exchanger, and adjusting it to the desired value.

We recommend the use of the load return riser type LTC 200 from the company ESBE, which is optionally available, or a comparable return riser. The use of other solutions (e.g. a four-way mixer) has not proved successful in practice and is, therefore, not recommended.

We cannot accept any liability nor provide guarantee cover for any malfunctions (sooting, deposits, etc.) or corrosion damage to the water heat exchanger or chimney etc. that are due to a missing or non-effective return riser.

## 3. OPERATING INSTRUCTIONS

Read these installation and operating instructions through carefully before installing or operating your stove. Make sure all objects are removed from the firebox and the ash pan (except for the firebox lining). Ask your specialist dealer to explain to you how to operate the stove and how it functions. National and European standards and local regulations must be observed when operating this fireplace.

### 3.1 GENERAL INFORMATION ON OPERATION

- Young children, the elderly or the frail: as with all heating appliances, a guard should be fitted to protect the above persons because both the glass door and the stove cover panels can become very hot in use. **Danger of burn injuries!** Never leave these groups of persons unattended near the stove when a fire is burning or has just been extinguished! Make these individuals aware of these risks.
- Never place any combustible objects on the exposed surfaces or cover panels of the stove. Never dry washing on the stove. Racks for drying washing should always be placed outside the radiant area of the stove.
- Burning fuel releases thermal energy which heats up the various parts of the stove, such as the surfaces, the door, the door handle and control handle, the viewing pane, the flue ducts, etc. Do not attempt to touch these components without adequate protection (i.e. heat-resistant gloves).
- **The enclosed heat protection glove is exclusively designed for operating the operating handle and the “cold hand”. The glove is not fire-proof!**
- The stove must always be operated with the firebox door closed. The door should always be kept closed, even when the stove is cold. The only times the door should be opened are when lighting the stove, when putting on more wood or when cleaning the stove.
- Do not modify the stove in any way. In particular, no parts that have not been expressly approved by Spartherm shall be placed in the firebox or in the flue gas or combustion air paths. Any modification to the fireplace without such express approval will void the warranty and operating permit.
- Extractor hoods, ventilators, etc. used at the same time as fireplaces in

the same room or in an adjoining room may interfere with the correct functioning of the stove (smoke may even escape into the living room). Such ventilation systems should never be operated at the same time as the stove unless appropriate precautions are taken (see 2.4.2 Non-room air sealed operation).

- When operating several fireplaces in a single room or linked space, ensure that sufficient air is available for complete combustion!
- This is a temporary fireplace thus, longer continuous burning is not achieved by piling up the fire repeatedly. Continuous burning without piling up the fire in-between cannot be achieved even through withdrawal of the combustion air and is not permitted. A longer heating period can be achieved by the appropriate addition of more fuel.
- Do not place any combustible materials in the lower compartment of the stove cover.
- For a4 H<sub>2</sub>O /a4 H<sub>2</sub>O RLU only: Due to the low flue gas temperatures, the chimney system must not be sensitive to moisture.

## 3.2 S-THERMATIK MINI

Supply voltage:	230V AC / 24V DC (via wall plug transformer)
Power consumption during operation	approx. 10 VA
Power consumption in "Stand-by":	ca. 6 VA
Protection class:	III (safety extra-low voltage)
Degree of protection:	IP 50

The S-Thermatik Mini combustion control is pre-set to your stove used ex-factory. Changes to the control parameters must only be carried out by an installer / stove fitter or the customer services. Please note the service instructions supplied!

### 3.2.1 INITIAL COMMISSIONING OF THE S-THERMATIK MINI

In order to guarantee an optimum and trouble-free operation of the fireplace, the door contact switch must be kept free from dirt and grime.

Before opening the combustion chamber door, make sure that the selector switch points to AUTOMATIC when the combustion air control is switched on. In automatic mode the control is activated from the stand-by by opening the combustion chamber door. Now the actuator motor runs the dosing facility for the combustion air to the position OPEN. The firewood is put in place and ignited (also see 4. Combustion), the combustion chamber door is closed. The combustion air is set and controlled automatically via the actuator motor on the basis of the flue gas temperature measured.

If the flue gas temperature is still below 50°C after 10 minutes (after closing

the combustion chamber door), the combustion air is closed again by the control without further signals. The air adjustment lever moves to the left. Heat-up error: The flue gas temperature increases above 50°C but the pre-set minimum temperature for starting the control is not reached: If the flue gas temperature drops below 50°C again, the combustion air supply is closed after another 15 minutes. An audible signal sounds. Reasons for a heat-up error could be that not enough, too much, too large or fuel that is too moist has been added, or the water heat exchanger pipes are blocked.

If there is a heat-up error and the flue gas temperature continues to increase, the combustion air supply is throttled depending on the flue gas temperature. Thus, the primary air (flows via the ash grate in the firebox) is closed first and then the secondary air is reduced (differential combustion air setting). In doing so, the combustion air lever moves from the right approximately to the middle in steps. In the further course of combustion and when the flue gas temperature drops, the combustion air quantity is reduced further.

In doing so, the combustion air lever moves from the middle further to the left.

Once the flue gas temperature has dropped far enough so that only embers are in the combustion chamber, you are prompted to add fuel by an audible tone. If the audible tone is not desired, this can be switched off. After the signal, you have approx. 10 minutes to add more fuel without having to use a firelighter. If fuel is added and the combustion chamber door is opened, the control opens the combustion air supply completely to 100% again. In doing so, the air control lever moves back completely to the right again.

If no fuel is added after the flue gas temperature has dropped even further, the combustion air is closed to a minimum. After the period of maintaining

the embers, the combustion chamber can be ventilated by opening the combustion air for three minutes. This function allows the ember bed to reduce further. After the venting process, the combustion air is closed completely (0%) and the control shifts to standby mode (control display off).

The correct operation of the S-Thermatik mini combustion control is indicated by a maintenance-free signal lamp that is mounted behind the fire symbol in the bottom flap and is displayed by the moving air adjustment lever.

If the air adjustment lever does not move after opening the combustion chamber door, the S-Thermatik Mini must be switched to manual mode by hand using the mechanical unlocking device (rocker switch). The selector switch is located in the supply air box and can be seen when the front cover of the stove is opened. The combustion air can be adjusted by hand via the air adjustment lever. Further details on manual setting can be found in 4.1.1 Combustion air regulation.

**The fireplace insert must never be put into operation with the combustion air supply (combustion air lever all the way to the left) closed!**

Heat-up errors and the prompt for adding fuel are indicated by an audible signal. The acoustic signal can be switched off using the rocker switch mounted on the control housing.

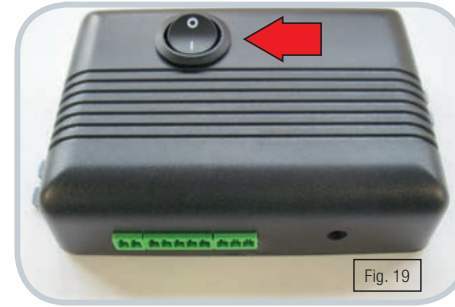

### 3.2.2 FUNCTIONAL TESTING OF THE S-THERMATIK MINI

When commissioning the control each time (inserting the wall plug transformer into the socket or when shifting the selector switch from manual to automatic), this carries out a self test when the combustion chamber door is closed. In doing so, the air adjustment lever moves from the left to the right and after a rest period of max. 1 minute, back to the left again. The air adjustment lever only moves to the left if the door contact and the flue gas temperature sensor are functional. The self test should be carried out when the combustion chamber is cold. When the combustion chamber is hot, the air adjustment lever does not move completely to the left, it takes the respective position according to the current flue gas temperature. After this self test, the control shifts to stand-by mode with cold stoves and "waits" until the combustion chamber door is opened.

Perform self-test:

- Move the selector switch to manual
- Insert the wall plug transformer into the socket
- Position the air adjustment lever in the middle by hand (about 50%)
- Move the selector switch to automatic

- The LED must light up and air adjustment lever must move to the right.
- If the lever firstly moves to the left, swap over the white and red wires on the control.
- The air adjustment lever must move to the right after max. 1 minute. If not, swap the blue and brown wires on the control with each other and repeat the self test
- Open the combustion chamber door, the air control lever must move to the right.
- End of the self test. Now you can fire-up the oven. If no fire is started, approx. 10 minutes after closing the door, the air adjustment lever moves back to the left to 0%.

### 3.3 FUNCTIONING OF THE ROTARY BASE

A rotary base can only be used with the ambiente a1/a2/a3/a4 models with top flue gas connection and must be specified when ordering. The base enables the stove to be rotated 180°, i.e. 90° to the left and 90° to the right (Fig. 20a).

#### Exempl using a2

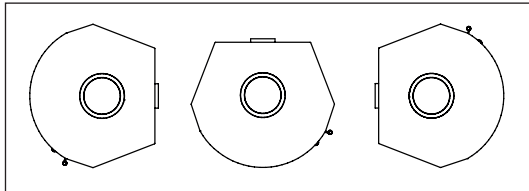

Fig. 20a

A	Rotated 90° to the left
B	Normal position
C	Rotated 90° to the right

To rotate the stove, turn the lever adjustment bolt. This is located in the lower door flap (see Fig. 20b). After rotating the stove to the desired position, raise the lever and turn it to the right to lock the stove in position (see Fig. 20b)

I	Raise the lever and turn it to the left
II	Rotate stove to desired position
III	Raise the lever and turn it to the right
IV	Rotate the stove until it locks into position

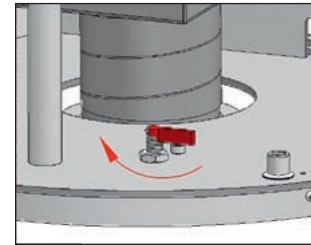

Fig. 20b I

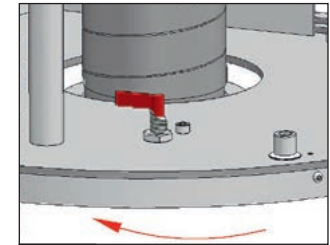

Fig. 20b II

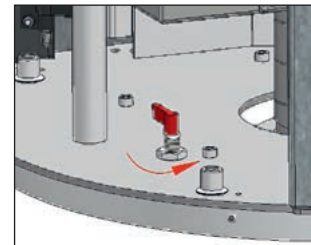

Fig. 20b III

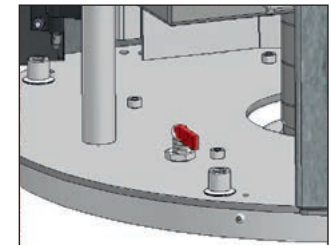

Fig. 20b IV



### 3.4 RATING PLATE

The rating plate can be found on your warranty certificate and on the rear of your stove below the ash pan or in the lower flap. It includes technical data and information. The rating plate must not be removed as it confirms the testing of the device and is required for the acceptance procedure and annual inspections by the chimney sweep.

### 3.5 OPERATION OF THE WATER HEAT EXCHANGER ON THE AMBIENTE a4 H<sub>2</sub>O/a6 H<sub>2</sub>O

The water heat exchanger is operated using the H<sub>2</sub>O Hebel on the back of the stove. This switches between the lighting-up/adding more fuel position and the combustion position. The lever does not have an intermediate position.

**Lighting up or combustion phase** (Fig. 21 B) The lever is right at the bottom. The flue gas is not routed through the heat exchanger. That allows the chimney draught to develop as quickly and effectively as possible.

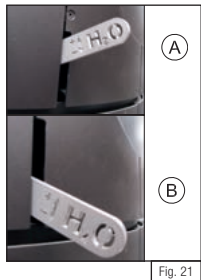

Fig. 21

Combustion position (Fig. 21 A) The lever is right at the top. All the flue gas will now be routed via the water heat exchanger. Wait for the stove to heat up fully, the fuel to catch light and embers to form before moving the lever to this position. That normally takes about 15-20 minutes.

A	Flue gas routed via water heat exchanger	B	Flue gas not routed via water heat exchanger
---	--	---	--

To keep the stove operating efficiently, be sure to add wood in time to prevent the flue gas temperature dropping too low.

## 4. COMBUSTION

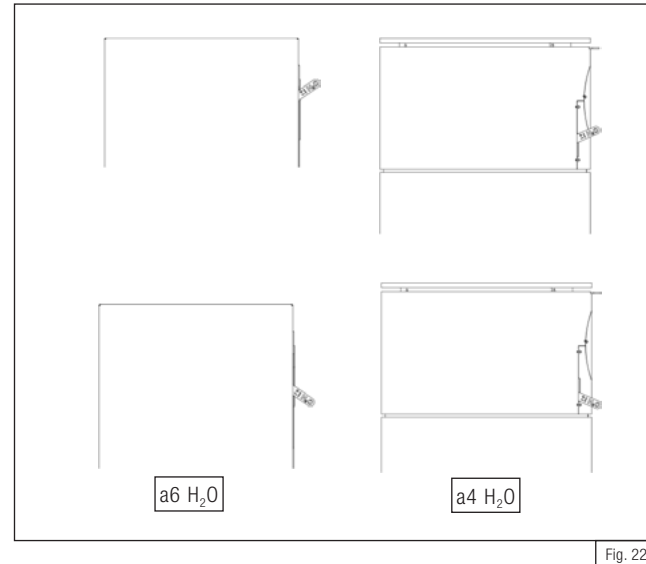

Fig. 22

## 4.1 INITIAL COMMISSIONING

The stove must be assembled and installed by a specialist contractor. The initial commissioning must only be executed by an expert employee of the installation company. A certificate confirming proper installation and proper adjustment / function of all control components and safety components must be given to the owner / operator of the system (see „9.1 Commissioning protocol ambiente a1/a2/a3/a4/a5/a6/a7/a8“ on page 53).

When first putting your appliance into service, only start a moderate fire. This enables you to avoid cracks in the firebox lining (which may still contain residual humidity before the first firing). Slowly increase the heating power to about 30% above nominal heat output by setting the fire 3 to 5 times to give the corrosion coating applied to the surfaces time to "burn in" properly. During this process, the paint can become slightly soft, do not place any objects on the stove and do not touch the appliance. During this burning-in process, an unpleasant yet harmless odour (sometimes accompanied by the build-up of smoke) may be given off. It is therefore important to ensure that the room is well ventilated during the burning-in process. Open all the doors and windows to let fresh air in.

Please note that slight expansion or contraction noises may be heard as the stove heats up or cools down. Such noises occur as the material expands at high temperatures, and are not a cause for concern.

### 4.1.1 INITIAL COMMISSIONING OF THE ambiente a4 H<sub>2</sub>O/a6 H<sub>2</sub>O

Commissioning must not take place until all the necessary components have been connected up, all necessary safety devices have been integrated and are operational, the water heat exchanger has been filled and the system has

been vented. It is not permissible to operate the system without water, when only partly filled or with safety devices that are not operational. It may be necessary to vent the water heat exchanger several times at commissioning.

The operator must also be given detailed instructions on the operation, functioning and maintenance of the entire system including all additional components. In addition, the measures for maintaining safe operation of the system must be communicated to the owner. Briefing must be documented in the commissioning protocol (see point 9 Commissioning protocol) The installation and operating instructions must always be kept in the vicinity of the ambiente a4 H<sub>2</sub>O/a6 H<sub>2</sub>O where they can be easily accessed.

Before commissioning it is important to check whether any objects are still inside the firebox or in the ash pan. If so, remove them.

**The stove is supplied with a ceramic fibre mat 3-5 mm thick on top of the deflector plate of the firebox lining. This is needed to soak up any condensate occurring the first three times the stove is lit. Before lighting the stove, check that the mat is lying snugly on top of the chamotte deflector plate. If the mat is not in position, condensate can drip on to the firebox lining, leaving permanent stains. The fibre mat can be removed after the stove has been lit 2 or 3 times.**

**Also, dirty condensate may leak from the bottom of the firebox and may soil or damage the floor underneath the stove. An absorbent material should therefore be placed under the stove the first few times it is used, until there is no more condensate leakage.**

Please note that slight expansion or contraction noises may be heard as the stove heats up or cools down. Such noises occur as the material expands at high temperatures, and are not a cause for concern.

## 4.2 COMBUSTION AIR REGULATION

Combustion air is regulated across an infinitely variable range using the actuating lever located below the door (Fig. 23). Adjustment takes place with the combustion chamber door closed!

**Air supply open (A):** For heating or for adding more firewood, move the actuating lever fully to the right. The firebox will now be supplied with the maximum amount of air for primary and for secondary combustion purposes. On the ambiente a5 the air adjustment lever should be moved upwards. The lever is located on the rear of the stove.

**Throttled combustion (B):** Adjustment lever roughly in the middle position. The primary air supply is now closed off, so that the fire is not supplied with too much air. The secondary air flows over the ceramic glass pane via the airwash which minimises sooting-up of the glass. This is the normal position during combustion. The exact position depends on local conditions and can be adjusted by the operator according to how the stove is burning.

**Air supply closed (C):** Adjustment lever at the far left. In this position, no combustion air is supplied to the firebox chamber of the stove. However, do not shut down the air supply altogether until the fuel has burned away completely. If the stove is not in operation, you should always close the air supply.

On the ambiente a5 the air adjustment lever should be moved downwards. The lever is located on the rear of the stove.

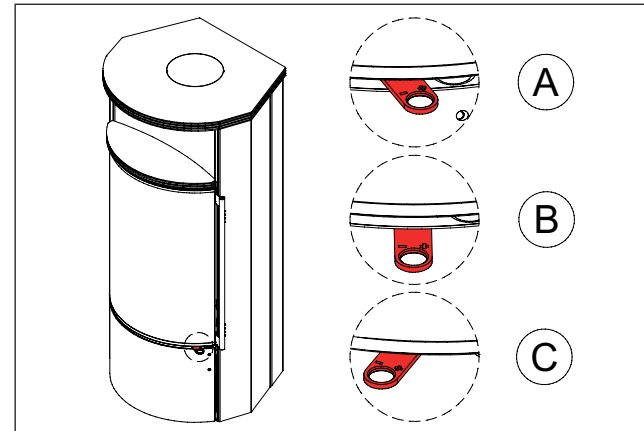

Fig. 23

A	Air supply open
B	Air supply throttled
C	Air supply closed

### 4.3 HEATING UP / BURNING

Lighting your stove is very easy if you follow the instructions below. We recommend combustion as above as this produces fewer emissions and smoke and thus causes less soiling of the firebox and panes.

1. The stove must not be operated unless the firebox lining is correctly installed.
2. Move the air adjustment lever to the firing up position (A) and open the combustion chamber door (swivel open).
3. Place two split logs in the firebox and build a pile of kindling (soft wood is best).
4. Place some standard firelighters on the pile to help light the fire. (Paper is not recommended as it burns away too quickly and causes flying ash)
5. Never use spirit, petrol, oil or any other highly flammable liquids.



6. Now light the fire by lighting the firelighters, and leave the combustion chamber door open about 3-5 cm. The fire should soon start burning strongly and brightly.
7. Once the kindling is well alight you can add some small hardwood split logs or larger softwood logs, piling them up on top.
8. Close the door once the logs are burning well. The air adjustment lever remains in the far right position (air supply open) and it should stay in that position for at least another 20-30 minutes to get the stove up to operating temperature.
9. More information about how much wood to put on the fire can be found in section Hourly wood consumption rate (4.2.2 Hourly wood consumption rate).

10. Once all the wood has fully burned away, more wood can be added as required (hardwood is ideal).
11. According to the weather conditions, move the air adjustment lever more or less to the centre position. This always depends on experience and on prevailing conditions on location.
12. Do not open the door forcefully or gases may enter your living room through a suddenly produced negative pressure. At first, open the door slowly and only a crack.
13. Putting fresh firewood onto hot embers you prevent the possible release of smoke when the door is opened.
14. Never repeatedly put more than the recommended amount of wood onto the fire.
15. If your chimney is drawing too strongly, the fire will blaze up even with only a minimal secondary air supply. Move the air adjustment lever slightly to find the best position for controlled combustion. Please note: the further you slide the air controller towards 'Air supply closed', the less air you are directing into the firebox. Ensure that you do not restrict the airflow too far, causing the fire to go out (6.7. Controlling heat output).

#### 4.3.1 ADDING WOOD / END OF THE COMBUSTION PROCESS

Wait for the wood to burn down to embers before adding more wood.

1. Move the air supply to the fully open position (position A)
2. Open the combustion chamber door very slowly (use the protective glove) to avoid turbulence which can encourage smoke to leak out.
3. Place the firewood on the embers (bark facing upwards, cut ends to either side. Make sure the air supply is open. The embers must not be starved of air).
4. Close the combustion chamber door (use protective glove!)

5. Leave the air adjustment lever in the fully open position (far right) for about 2 to 5 minutes. Wait for all the new wood to catch light before altering the air adjustment lever position again.



6. Then move the lever to the middle position B.

The end of the burning process is achieved when the wood has burned completely, and no smoldering or incomplete combustion can occur. Now the lever can be closed. Always leave the air adjustment lever in the closed position C when the stove is not in use (see Fig. 23).

### 4.3.2 HOURLY WOOD CONSUMPTION RATE

In order to avoid damage due to over-heating (discolouration of the steel, deformation, etc.) and to guarantee optimum performance over the lifetime of the appliance, ensure that the stove is fuelled in the proper manner. To prevent any risk of over-heating, make sure that the maximum heating capacity is never exceeded.

The proper amount of wood feed per hour can be found in „2.2 Technical data“ on page 6. The individual wood logs should be no more than approx. 25 cm in circumference!

Please note: Increasing the wood feed beyond this amount may result in overheating and damage to the stove. Wood pellets (briquettes) have a higher heat output than hardwood. Hourly consumption when using pellets should therefore be at least 20% lower than when burning logs.

The warranty will be voided in cases of damage due to overheating (excessive hourly wood consumption).

## 4.4 CONTROLLING HEAT OUTPUT

Heat output is controlled by regulating the amount of fuel added. Do not try to slow down combustion excessively by reducing the flow of inlet air. When heating with wood, this causes incomplete combustion and therefore wastes fuel and causes unnecessary levels of environmental pollution because wood releases gases even if no flames are produced. This also increases the soot deposits on the viewing panes! What is more, there is the risk of deflagration (explosive ignition of the flue gases).

Ensure that the firebox door is always firmly closed to prevent combustion being accelerated by the uncontrolled inflow of air. Your stove's output also depends on the chimney draught. This draught can be adversely affected by the cross section of the chimney, or by environmental factors such as strong winds etc.

## 4.5 ROOM HEATING CAPACITY / INDOOR CLIMATE

The room heating capability used to be quoted in accordance with the DIN 18893 standard (most recent edition being August 1987) so is no longer a meaningful indicator for modern houses constructed after 1990. However, the old room heating capacity value may still be of interest as a comparative value or for use in the case of older structures pre-dating the 1977 thermal insulation standard.

	Room heating capacity* of ambiente stoves when used intermittently						
<b>Heating conditions</b>	a1/a2/a3/a4/RLU	a4 H <sub>2</sub> O*/RLU	a5	a6	a6 H <sub>2</sub> O* (7.0kW)	a6 H <sub>2</sub> O* (11.0kW)	a7/a8
<b>favourable</b>	144 m <sup>3</sup>	43 m <sup>3</sup>	186 m <sup>3</sup>	165 m <sup>3</sup>	56 m <sup>3</sup>	88 m <sup>3</sup>	88 m <sup>3</sup>

Considerably bigger rooms can be heated with modern thermal insulation.

\* Direct room heating not including water heating

Precise descriptions of the terms 'favourable', 'less favourable' and 'unfavourable' can be found in DIN 18893. Simply put, 'favourable' describes a situation where the room has only one external wall and otherwise mainly adjoins heated internal rooms, whereas 'unfavourable' refers to a room with two external walls and adjoining unheated rooms.

The values indicated above refer to structures pre-dating the 1977 thermal insulation standard. They represent a simplification which is valid for room sizes up to 200 m<sup>3</sup>. DIN 18893 standard recommended a calculation according to DIN 4701 for rooms larger than 200 m<sup>3</sup>. Nowadays, an estimate according to TR-OL is preferable or, in particular, the calculation should be based on DIN 12831.

#### 4.6 HEATING IN THE TRANSITIONAL PERIOD / UNFAVOURABLE WEATHER CONDITIONS

In the transitional period, when the outside temperature is above approx. 15°C, or during unfavourable weather conditions (down winds, etc.), disruption to the chimney draught may occur due to sudden rises in temperature, with the result that the flue gases are not completely extracted. In these circumstances a smaller amount of fuel should be placed in the stove and the air adjustment lever should be moved to the maximum position (see „4.2 Combustion air regulation“ on page 35). The fuel in the stove will then

burn away faster (with more flames). This will help to stabilise the chimney draught. To avoid resistance in the firebed, it should be carefully raked at frequent intervals to remove the ash. The air supply can be reduced slightly (middle position B) when the chimney draught has stabilised.

## 5. FUEL

Stoves may only be operated using fuels that correspond to the 1st BImSchV regulations. Only firewood (recommended residual moisture 20% or less) or wood pellets according to DIN 51731 are permissible for use in stoves. Incidentally: A measuring device for determining the moisture of firewood does not cost very much and quickly pays off.

### Do not use any other fuels!

It follows from this that it is not permitted to burn:

- Varnished or plastic-coated wood
- Chipboard or wood that has been treated with wood preservatives
- Wood originating from Europool pallets
- Rubbish, household waste, old clothes
- Paper, paper briquettes, cardboard
- Coal, coal briquettes, brown coal
- Damp wood (residual humidity > 20%)
- Plastics / foam material of any sort
- Any solid or liquid materials that contain no wood

It is prohibited to burn these or other inappropriate materials in your stove. When burning other materials than the permitted fuels, firewood or wood briquettes defined in DIN 51713, toxic gases can be formed that have an adverse effect on the combustion process, and that may even cause explosions.

Operating stoves with other than the approved fuels renders the warranty invalid!

Use small pieces of wood to get the fire going. For firewood, use only split wood that is not thicker than about 8 cm at its thickest point. The optimum length of firewood is approximately 25 cm. Please do not add too much wood at one time. Instead, it is better to add smaller quantities of wood at regular intervals. When adding wood to the fire, the embers must not be completely covered.

## 5.1 CO2 NEUTRALITY

Wood only releases as much carbon dioxide as it collected and trapped from the air as a tree. It is irrelevant in this case whether the wood is burned or rots in the forest – the carbon dioxide released always remains the same. A closed natural carbon dioxide cycle is produced.

Conclusion: When burning wood, nature remains in balance. German Law legislates for the sustainable management of forests. This obligation leads to an increase in timber volumes, since the average increase in timber is 40% greater than the amount of firewood and timber that is consumed.

### 5.1.1 WOOD STORAGE

In general, it is recommended to store firewood for approx. 2-3 years, the wood should be protected from dampness and well ventilated (e.g. under a roof overhang on a side of the building protected from the weather). Wood with moisture content < 20% will be achieved significantly quicker with optimal storage.

Therefore, you should store your firewood already chopped because the bark can prevent the moisture escaping from the wood. You should leave a distance the width of a hand between the logs for good ventilation so that the air can circulate properly and the moisture escaping from the wood can be taken away by the air. A distance to the floor of approx. 20-30 cm should be maintained underneath the stack of wood. Renewed absorption of moisture due to precipitation (e.g. rain or snow) should be avoided. Storing wood in garages, under plastic sheets or in poorly ventilated cellars is not recommended because the moisture present in the wood cannot escape properly.

## 5.2 YOUR CONTRIBUTION TO ENVIRONMENTAL PROTECTION

Whether or not your stove burns in an environmentally-friendly way is very much dependent on the choice of fuel and the manner, in which the fire is operated. The following tips should help you operate your stove with minimum harm to the environment:

- Use as little wood containing resin as possible (fir, pine, spruce). These types of wood cause soot to form on the window of your stove more rapidly, and also cause more sparks. Therefore, for safety reasons, only use deciduous woods (birch, beech, oak, fruit tree timber).

- Adapt the amounts of wood you add to the fire to suit your heating requirements.

You can check that combustion in your stove is clean and relatively free of pollutants in the following way:

- The ash should be white. If the ash is dark, this indicates the presence of residual carbon, which in turn indicates incomplete combustion.
- The flue gas from the chimney stack should be virtually invisible (less smoke means improved combustion).
- The firebox lining in your stove should be bright after combustion, not sooty.

**Note:** The fireplace must not be used as a waste incinerator! Furthermore, this is a temporary fireplace thus, longer continuous burning is not achieved by piling up the fire repeatedly. Continuous burning without piling up the fire in-between cannot be achieved even through withdrawal of the combustion air and is not permitted.

## 6. CLEANING AND CARE

The stove may only be cleaned when cold. Bear in mind that through cleaning, soiling of the setup room and the clothing worn can occur. We recommend that you protect the area around the combustion chamber opening against soiling with foil or with a cloth and that you also wear work clothes. All the disassembled parts are to be assembled again after cleaning.

### 6.1 CLEANING OF FIREBOX / CLADDING PARTS

- The stove, firebox, smoke collecting chamber with heating gas diverter, combustion air system and the connecting pieces for the chimney must be examined for deposits at regular intervals annually and possibly also during and after each heating season and after cleaning the chimney and, if necessary, cleaned (consult your stove dealer or local chimney sweep). Deposits are to be removed using a hand brush and/or ash vacuum (specialist dealer). The chimney must be cleaned at regular intervals by the chimney sweep. Furthermore, the stove should be inspected annually by a specialist.
- Flue gas diverter: Above the firebox, in the flue gas manifold, there is also a flue gas diverter. This must be cleaned regularly. To this end, the flue gas diverter can be removed. It must be lifted up, tilted and removed through the firebox. Deposits on the diverter can be simply removed using a handbrush.
- Ash removal: Your stove is suitable for the combustion of dry wood which should ideally burn in its own ash. Should, however, you prefer to remove the ash from the firebox, open the stove door. Lift the grates out of the firebox and, using a standard companion set, brush the ash into the ash drawer below. Remove the drawer and dispose of the contents properly. If your stove does not have an ash grate, the ash is to be removed from the firebox using a companion set.
- Note that the ash can keep the embers hot for up to 24 hours and longer!
- Cleaning the ceramic glass pane: You can easily clean the glass panel with a commercially available cleaning agent for fireplace glass.
- Use dry cloth to wipe. No scouring.
- Please do avoid that excess cleaning agent enters between door frame and glass panel. This might cause the hardening of the sealing compound between glass panel and door frame. A hardened sealing



compound might lead to damages of door and glass.

- Suitable cleaning agents for fireplace glass are available at your specialist dealer.
- Painted surfaces and the cladding parts can be cleaned with a moist cloth (do not use a microfibre cloth!) without cleaning agents.
- Glass surfaces can be cleaned with a standard glass cleaner and a soft cloth (do not use a microfibre cloth!) without cleaning agents.
- Stainless steel surfaces can be cleaned with standard stainless steel cleaning agents! Only use in the direction of the finish!
- Natural stone surfaces can be cleaned with a wet cloth or suitable standard cleaning agents!
- Ceramic surfaces can be cleaned with a wet cloth or suitable standard cleaning agents!

Remove any dust on and below the stove regularly during the heating season as dust particles can burn or char. This can cause dirt and odours in the room and on the furnishings where the fire is installed.

## 6.2 FIREBOX LINING

In the heating-up phase it is normal for the lining to have a dark coating. After reaching the operating temperature, the firebox lining burns freely. Cracks are not grounds for a justified complaint. The lining is subjected to very high loads. A tension or expansion crack is not a matter for concern nor is it a functional fault. Nevertheless, broken and dislodged bits of firebox lining must be replaced. If replacement chamotte is required, you can order this from your stove fitter

stating the relevant article number and model (see Fig. 24-28).

Item	Designation	a1-a4, a4 H <sub>2</sub> O, a1 RLU-a4 RLU, a4 H <sub>2</sub> O RLU	a5	a6, a6 H2O	a7	a8
<b>Individual chamotte stones</b>						
1	Front floor stone	1032574	1017977*	-	-	-
2	Rear floor stone	1032575	1017978*	-	-	-
3	Left floor stone	-	-	1019832	1021259**	1021259**
4	Right floor stone	-	-	1019832	1021259**	1021259**
5	Deflector plate	1012907	1017976	1019837	1019837	1019837
6	Top rear wall stone	1012908	1017984	-	-	-
7	Bottom rear wall stone	1012909	1017983	-	-	-
8	Left front side stone	1012910	1017979	-	-	-
9	Left rear side stone	1012911	1017981	-	-	-
10	Right front side stone	1012912	1017980	-	-	-
11	Right rear side stone	1012913	1017982	-	-	-
12	Left-hand side wall stone	-	-	1019835	1019835	1019835
13	Right-hand side wall stone	-	-	1019835	1019835	1019835
14	Edge stone	-	-	1019834	1019834	1019834
15	Rear wall stone	-	-	1019836	1019836	-
<b>Complete chamotte set without deflector plate</b>						
Complete chamotte set without deflector plate		1041762	1018734*	1041760	1024592**	1024593**
<b>Accessories</b>						
Grate (for insertion)		-	1006404	-	-	-
Folding grate		1019824	-	1019824	-	-
Ash drawer		1041859	1041860	1041861	-	-

\*Grate for insertion

\*\*No grate

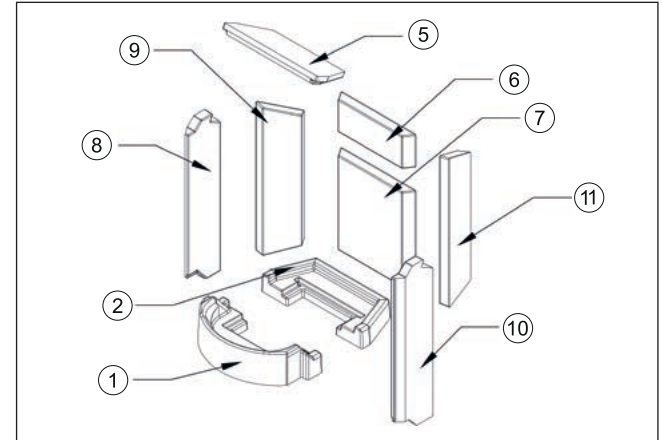

ambiente a1-a4/a4 H<sub>2</sub>O/RLU Fig. 24

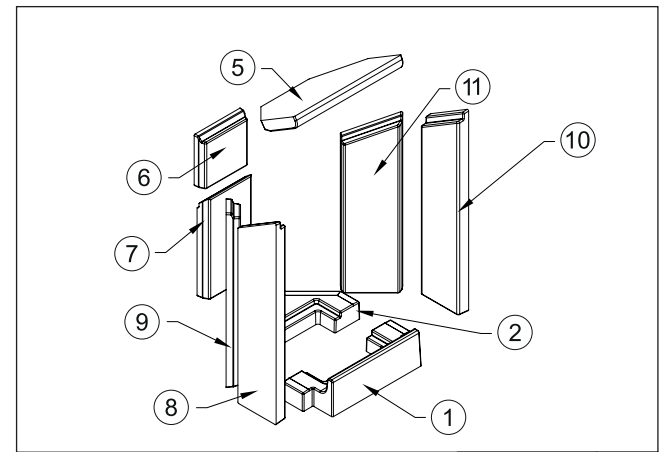

ambiente a5 Fig. 25

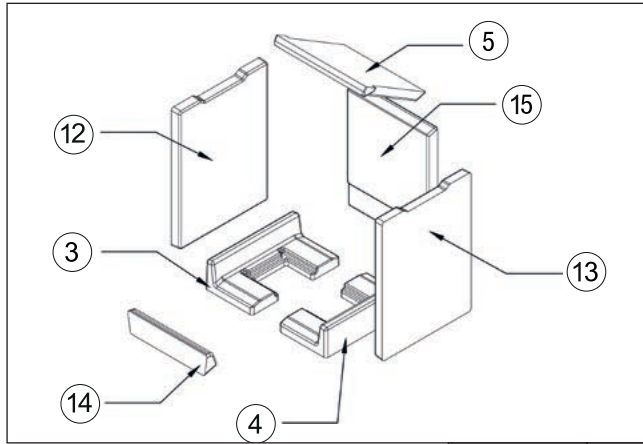

ambiente a6/a6 H<sub>2</sub>O Fig. 26

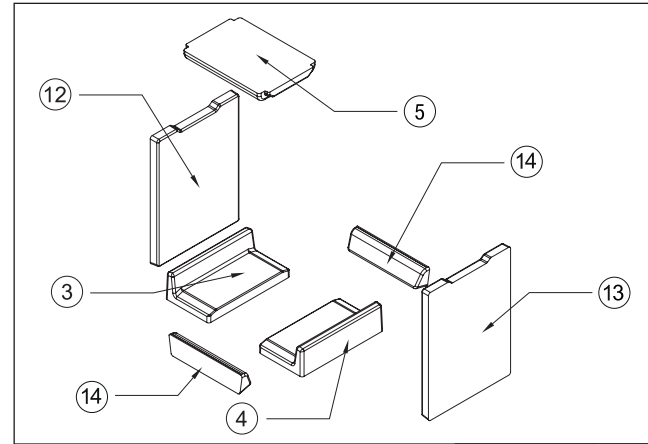

ambiente a8 Fig. 28

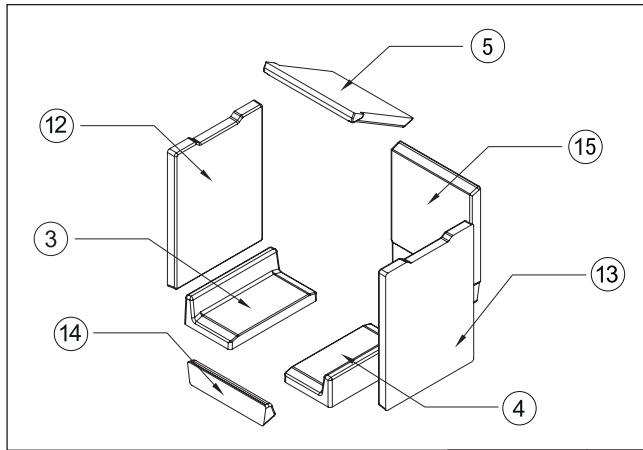

ambiente a7 Fig. 27

### 6.3 CHIMNEY FIRE

When burning wood (especially softwood), sparks can often be transferred from the fireplace to the chimney. This may ignite the soot in the chimney. This rarely happens if the chimney is cleaned regularly by the chimney sweep. The chimney catches fire. This can be recognized by flames that blaze from the chimney opening, excessively flying sparks, smoke and odours, as well as the chimney walls becoming progressively hotter. It is important to act properly in such cases. You can alert the fire brigade by dialling 999 (or 112 in Germany). The chimney sweep must also be informed. Combustible objects should be located away from the chimney.

Attention: Do not attempt to extinguish the fire with water before the fire brigade arrives on the scene. Temperatures in a chimney fire can reach up to 1300°C. Extinguishing water would immediately create steam. A 10-litre bucket of water yields 17 cubic meters of steam. The enormous pressure created as a result could cause the chimney to disintegrate. Once the chimney fire has burnt itself out, the chimney must be examined by a specialist for cracks or leakages and, if required, repaired accordingly.

## 6.4 MAINTENANCE

The door seal must be checked at regular intervals! If necessary replace the seal (in the case of wear, cracks etc.).

The firebox lining is made of natural products and must thus be checked at regular intervals. It is made of natural products that expand and contract with every heating process. This can cause cracks to appear. The firebox lining will remain fully functional provided it is still in position and not broken. A crack in the chamotte stone is thus not cause for complaint. For proper functioning, annual maintenance of the stove by a specialist (preferably before the heating season) is essential!

### **For non-room air sealed stoves the following also applies:**

A proper door seal is of elementary importance for stoves with non-room air sealed operation. Check the seal for visual features (pressure, wear, dents) at least once per heating season and change immediately if damaged.

The fireplace must never be modified! Only original spare parts that have been approved by the manufacturer may be used! If you have any questions,

please contact your specialist dealer.

## 6.4.1 LUBRICATION GUIDE FOR DOOR LOCKS WITH SMARTCLOSE

Stove and fireplace inserts with SmartClose door locking mechanisms must be lubricated at regular intervals to assure problem-free operation (once per heating season). For this purpose, the scope of delivery of each fireplace includes a tube of special stove lubrication compound. This lubricating compound is applied to facilitate ease of movement of heavy fire doors, and to prevent noise caused by opening and closing the fire doors. The lubricating compound must be applied at least once a year to the spring connection



Fig. 29a

on the SmartClose and its associated roller. With fireplaces used frequently or very frequently, it may be necessary to shorten this lubrication interval. Depending on the stove or type of fireplace insert, the door lock springs may be located below and/or above or to the side of the combustion chamber door. In order to lubricate the lock, you may use a standard cotton swab as an aid. To apply the lubricant

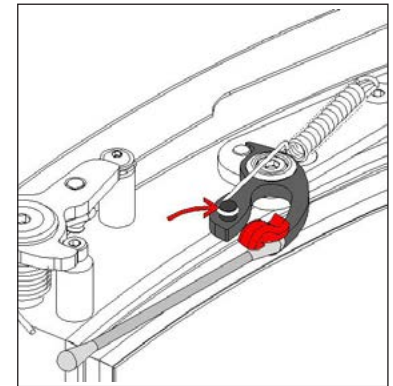
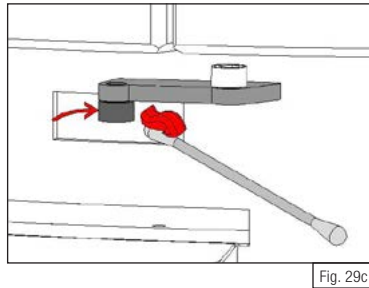

Fig. 29b

compound, proceed as follows:

Open and secure the combustion chamber door. Apply a little lubricant compound to the cotton swab and use it to coat the spring support (see Fig. 29b) on the door lock. Turn the locating roller on the body of the stove by hand during this application process (see Fig. 29c).. Open and close the fire door a few times and, if necessary, apply the lubricant compound once again.

**Caution: Ensure that no copper lubricant compound makes contact with cladding parts or similar items! Remove dirt and grime straightaway with a cotton cloth. Never operate the equipment during intervening periods.**



#### 6.4.2 MAINTENANCE OF THE WATER HEAT EXCHANGER OF THE AMBIENTE A4 H<sub>2</sub>O / A6 H<sub>2</sub>O

The ambiente a4 H<sub>2</sub>O/a6 H<sub>2</sub>O must be maintained. The stove can only function at full efficiency if it is regularly and properly serviced. The technical heating inspection and checking of all safety devices (thermal discharge safety device etc.) is required yearly before the heating season. This check must only be executed by a specialised company. We recommend that you conclude a maintenance contract with your specialised company. This guarantees that the annual safety inspection is reliably performed before the heating season. The executed yearly safety inspections must be

documented!

#### 6.4.3 VENTING THE WATER HEAT EXCHANGER OF THE AMBIENTE A4 H<sub>2</sub>O / a6 H<sub>2</sub>O

The vent is located in the heating connection area, in the lower compartment. The vent must be opened with a bleed key. A suitable container or large towel should be kept at the ready to collect any water which leaks out. A small tube can be attached to the vent. Upon opening the valve, water firstly comes out of the vent line followed by air a few seconds later. Once the air has escaped, the valve should be kept fully open for a further five seconds.

The system must be vented:

- Before and during initial commissioning.
- Daily over the course of the following weeks until no more air escapes.
- If sounds (air bubbles) can be heard in the heat exchanger.
- If the pressure of the domestic water supply has been adjusted.

#### 6.5 CLEANING THE WATER HEAT EXCHANGER OF THE AMBIENTE a4 H<sub>2</sub>O / a6 H<sub>2</sub>O

Cleaning the water heat exchanger is absolutely necessary. Regularly and properly servicing allows the stove to function at full efficiency. Cleaning must always be executed in cooled-down status!

Because the water heat exchanger directly cools down the flue gases and this unavoidably results in deposits on the surfaces of the heat exchanger, these surfaces must be cleaned with the integrated cleaning system on a regular basis.

**The water heat exchanger should be cleaned once daily, or each time the ash drawer is emptied, once it has cooled down.** Regular operation of the

cleaning system prevents the system from seizing.

If after the first cleaning operations, it is noticeable that little to no deposits were removed, this means that you can extend the cleaning interval for your operating conditions. If, on the other hand, heavy deposits are found during cleaning, then cleaning must be carried out more frequently and the cleaning interval must be shortened.

If the cleaning mechanism can only be operated with increased force after prolonged operation, this is an indication of disproportionate contamination of the water heat exchanger. In this case, please check the moisture content of the fuel (< 20 %) and make sure that the heating integration works properly (min return temperature > 62°C). If you are not sure that these conditions have been complied with, please contact your installer for heating installations. When inserting the operating handle, ensure that it does not hit the painted edges! The soot discharged by cleaning automatically falls onto the baffle plate in the combustion chamber and should be cleaned off from there at least 2 times per season.

#### **Cleaning process for a4 H<sub>2</sub>O:**

The operating handle is included in delivery and must be inserted in the 20 mm hole on the top left side of the unit when cleaning. Then actuate the operating handle about 5 times up to the stop (20° angle of rotation). When inserting the operating handle, ensure that it does not hit the painted edges of the stove!

#### **Cleaning process as of a6 H<sub>2</sub>O:**

The actuation handle is located on the rear of the stove in the top right-hand corner. This must be pressed approx. 5 times up and down as far as it will go.

Any soot which results from cleaning automatically falls onto the deflector plate

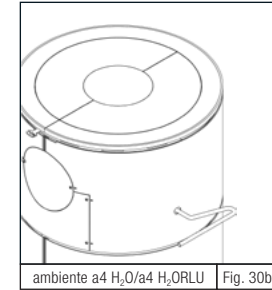
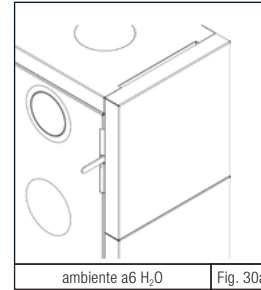

in the firebox and should be removed from here at least twice per season.

<b>problem</b>	<b>Cause, explanation</b>	<b>Chapter note</b>	<b>Solution</b>
Glass becomes sooted heavily, rapidly and unevenly.	You did not use the correct combustion materials.	5.	Use natural, bulky bits of timber compliant with 1st BImSchV §3 (German legislation).
	The ambient temperature is above about 15°C. The weather conditions are unfavourable (e.g. fog). These weather conditions occur most frequently in spring and fall.	4.6	Fill the fireplace with a small amount of fuel and light it with the damper fully open (max. air flow).
	There is a temperature inversion. That means that the upper layers of the atmosphere are warmer than the lower layers.	4.6	Fill the fireplace with a small amount of fuel and light it with the damper fully open (max. air flow).
	The combustion air controller is not fully opened.	4.2	Move the air actuating lever into its far right-hand position.
	The external combustion air line is not free.	2.4.3	Clean the combustion air line.
	Combustion air is too heavily restricted. This means that soot accumulates quickly, within just half an hour. (it is normal for operation of the system to make the fireplace unit progressively more dirty. When driving, a car window becomes dirty, too!)	-	Check the position of the air lever and, if necessary, open up the combustion air flow rate fully to bring the fireplace unit up to operating temperature.
	The seating of a gasket is not perfect.	-	Check all seals, e.g. open the fire door and press the seal fully into the door profile.
	The wood is not dry enough.	5.	Measure the residual humidity in the wood used with a humidity detector. The recommended residual humidity is 20% or less.
	Not enough wood has been added. (an insufficient amount of wood can result in temperatures in the stove not being high enough).	4.3.2	The proper amount of wood feed per hour for your tiled stove can be found in the technical data.
	The chimney draught is too strong / too weak.	-	Observe the situation. The draught characteristics can be affected by the prevailing weather pattern. If the glass continues to soot up badly, inform your chimney sweep.
Fire is difficult to ignite	You did not use the correct combustion materials.	5.	Use natural, bulky bits of timber compliant with 1st BImSchV §3 (German legislation).
	The wood is not dry enough.	5.	Measure the residual humidity in the wood used with a humidity detector. The recommended residual humidity is 20% or less.

<b>problem</b>	<b>Cause, explanation</b>	<b>Chapter note</b>	<b>Solution</b>
Fire is difficult to ignite	The wood too thick.	5.	Use small-sized timber to light the fire. For firewood, use only split wood that is not thicker than about 8 cm at its thickest point. The optimum length of firewood is approximately 20 - 25 cm. In the case of prolonged heating, do not add too much wood. Instead, it is better to add smaller quantities of wood.
	A sufficient air supply is not assured.	4.2.	For lighting the fire or adding more firewood, move the actuating lever fully to the right.
	The ambient temperature is above about 15°C. The weather conditions are unfavourable (e.g. fog). This is referred to as an intervening period.	4.6	Fill the fireplace with a small amount of fuel and light it with the damper fully open (max. air flow).
	There is a temperature inversion. That means that the upper layers of the atmosphere are warmer than the lower layers.	4.6	Fill the fireplace with a small amount of fuel and light it with the damper fully open (max. air flow).
	The combustion air controller is not fully opened.	4.2	Move the air actuating lever into its far right-hand position.
	The external combustion air line is not free.	2.4.3	Clean the combustion air line.
	The chimney is not unobstructed.	-	Inform the chimney sweep.
	There is not enough vacuum in the chimney.	-	Light a small fire in the fireplace, following advice from your fireplace installer or chimney sweep.
Smoke escapes when adding wood	Air-extracting equipment is switched on, e.g. kitchen extractor fan.	-	Ensure that all air-extracting equipment is switched off.
	Wood added prematurely, on top of unburned wood.	4.3.1	Do not add fresh firewood until there is a bed of hot embers in the combustion chamber.
	The chimney is not unobstructed.	-	Inform the chimney sweep.
	Your fireplace has not already reached its operating temperature.	-	Burn down remaining wood until it forms a bed of hot embers, then add smaller pieces of firewood.
	The door has been opened too wide.	4.3.1	Open the door slowly and carefully.



Combustion too fast / wood consumption too high	The diameter of your stack of wood is too small.	4.3.2	The ideal diameter for a stack of wood is about 25 cm.
	The chimney draught is too strong.	-	Inform the chimney sweep. Perhaps increase combustion air flow to counteract choking action.
	The combustion air flow has not been reduced.	4.2	Leave the actuating lever in about its centre position.
	Ever since the initial blaze, the fire door has been slightly open.	-	Close the fire door!
	The recommended wood feed quantity has not been observed.	-	The proper amount of wood feed per hour for your tiled stove can be found in the technical data.

## 7. TROUBLESHOOTING

### 7.1 WATER HEAT EXCHANGER OF THE A4 H<sub>2</sub>O

Problem description	Cause / solution:
Thermal discharge safety device trips constantly (constant water outflow through the discharge). The water heat exchanger cannot dissipate heat to the heating system.	<ul style="list-style-type: none"> <li>The buffer tank is "full".</li> <li> Warning: Remove heat from the heat storage mass</li> <li>Check function and settings of the pump thermostat and the return riser.</li> <li>Set the pump one level higher (higher flow rate).</li> <li>Circulation pump does not run. Is the power connection defective?</li> <li>Vent the stove.</li> <li>Check system pressure.</li> </ul>
When initially used, water leaks out of the base of the system.	<ul style="list-style-type: none"> <li>If the stove and heating installations are tested under pressure after assembly, the water which leaks out is condensation from the fuel and firebox lining. If more than 0.2 litres of water accumulate, the heating system pressure must be checked.</li> </ul>
Gurgling sounds in the water heat exchanger. Air in the system.	<ul style="list-style-type: none"> <li>Check system pressure.</li> <li>Ventilate system via the vent. For newly filled or topped up systems it takes some time for all the air to collect. Often ventilating once does not suffice.</li> </ul>
Thermal discharge safety device drips.	<ul style="list-style-type: none"> <li>Flush the thermal discharge safety device by activating the red button on the fitting.</li> <li>Check the seat of the connection seals and the piston (see the instructions on the thermal discharge safety device).</li> <li>If necessary, integrate filter in the system upstream of the discharge safety device (pay attention to the minimum flow rate!)</li> </ul>
Radiators do not warm up. Radiators which are not in the installation room are cold.	<ul style="list-style-type: none"> <li>Close radiator thermostats when the set room temperature is reached. The convection heat of the fireplace is distributed in the air composite.</li> <li>Depending on the configuration the heating system is sluggish. It takes some time until the heating system dissipates its heat.</li> <li>Have the heating system hydraulically calibrated.</li> <li>Check heating circuit pump for function.</li> <li>Increase fuel feed rate.</li> </ul>

Problem description	Cause / solution:
Increasing and faster contamination of the firebox lining and of the glass ceramics. The firebox lining no longer burns free. Fire can only be ignited with difficulty	<ul style="list-style-type: none"> <li>Remove deposits in the heat exchanger and in the connecting line to the chimney.</li> <li>Check that the pump thermostat is functioning correctly.</li> <li>Pay attention to correct firing, wood feed quantity, wood moisture content &lt; 20%.</li> <li>Correct the position of the air adjustment lever.</li> <li>Check that the return riser is functioning correctly.</li> </ul>
Rapid soiling of the flue gas lines in the water heat exchanger. Insufficient combustion performance.	<ul style="list-style-type: none"> <li>Check return riser.</li> <li>Pay attention to correct firing, wood feed quantity, wood moisture content &lt; 20%.</li> <li>Remove deposits in the heat exchanger and in the connecting line to the chimney.</li> <li>Check that the pump thermostat is functioning correctly.</li> </ul>

## 8. GENERAL WARRANTY CONDITIONS

**Service hotline 0180 594 41 94**  
 14 cents/minute incl. VAT from a German landline, max. 42 cents/minute  
 incl. VAT. from a German mobile network

### 8.1 AREA OF APPLICATION

These standard warranty terms apply for the contractual relationship between the manufacturer, Spartherm Feuerungstechnik GmbH, and the dealer/distributor. These warranty conditions are not identical to those warranty terms governing relations between the dealer or distributor and his customers.

## 8.2 GENERAL INFORMATION

This product has been manufactured in compliance with current standards of quality control. The materials used have been carefully selected and - like our entire production process - are subject to on-going quality control. Specialist knowledge is required when assembling and installing the product. The product must, therefore, only be installed and commissioned into service by specialist technical staff, in compliance with current statutory provisions.

## 8.3 WARRANTY PERIOD

The standard warranty terms only apply within Germany and the European Union. The warranty period and scope of the warranty are ensured within the framework of these conditions outside the statutory warranty which remains unaffected. Spartherm Feuerungstechnik GmbH offers a 5-year guarantee in respect of:

- Main carcass of fireplace inserts
- Main carcass of fireplace stoves
- Main carcass of fireplace cassettes
- Main carcass of fireplace doors

Spartherm Feuerungstechnik GmbH offers a 24-month guarantee in respect of the sliding door mechanism, operating components such as handles, setting levers, shock absorbers, electrical and electronic components such as fans, rotational speed controllers, the manufacturer's original spare parts, all items purchased as additional extras and all safety appliances.

Spartherm Feuerungstechnik GmbH offers a 6-month warranty on wear parts in the fire area, e.g. chamotte, vermiculite, fire grates and glass ceramic.

## 8.4 WARRANTY REQUIREMENTS

The warranty period shall begin on the date on which the product is delivered to the dealer / distributor. Invoices or delivery notes may be used as confirmation of the warranty commencement date. The warranty certificate for the product must be presented by the claimant upon making a warranty claim.

Spartherm Feuerungstechnik GmbH is not obliged to satisfy any claim if such documentation is not presented.

## 8.5 WARRANTY DISCLAIMER

This warranty does not cover:

- Wear to the product
- Chamotte/vermiculite: natural products which expand and contract upon exposure to any heating process. This can cause cracks to appear. The firebox linings will remain fully functional, provided they are still in position and are not broken.
- The upper surfaces: discolouration of the coating or galvanic upper surfaces, due to excessive thermal loading or over-heating.
- The vertical sliding mechanism: Failure to comply with installation guidelines, resulting in over-heating of the guide rollers and bearings.
- The gaskets and seals: Reductions in sealing strength due to seal hardening as a result of thermal loading.
- The glass ceramics: Soiling, due to soot or other burnt-on combustion

materials and visual deterioration due to thermal loading.

- Careless transportation and/or incorrect storage:
- Inappropriate or careless handling of fragile components, such as glass or ceramics
- Improper handling and/or use
- Lack of maintenance
- Incorrect installation or appliance connection
- Failure to comply with installation instructions and operating instructions
- Technical modifications made to the appliance by staff from other companies

## 8.6 ELIMINATION OF DEFECTS / REPAIR

Independent of any statutory provisions acknowledged as taking precedence over the terms of this warranty, all necessary repair works resulting from material or manufacturing defects shall be carried out free-of-charge and shall not invalidate the remaining provisions of the warranty. Within the scope of this warranty promise, Spartherm Feuerungstechnik GmbH reserves the right to either remedy the fault or replace the device free of charge. The elimination of defects shall take precedence.

The terms of this warranty shall not extend to any damage or compensation not covered by statutory provisions.

## 8.7 EXTENSION TO THE WARRANTY PERIOD

The warranty period shall automatically be extended, where claims made in respect of these warranty provisions result in the repair or replacement of defective equipment.

## 8.8 SPARE PARTS

Only the manufacturer's own components, or replacement parts recommended and approved by the manufacturer, shall be used for appliance servicing and repair.

Damages and claims for compensation which are not the result of delivery of a defective appliance from Spartherm Feuerungstechnik GmbH are excluded and are not part of this warranty promise.

The above shall not include claims made in respect of statutory legal requirements.

## 8.10 CLOSING REMARKS

In addition to these warranty conditions and our commitment to them, our dealers and contractual partners are pledged to assist you in both word and deed. We expressly recommend that our fireplaces and stoves are regularly inspected by a qualified technician.

We reserve the right to make alterations to the technical data contained herein and accept no liability in respect of any errors made.

# 9. COMMISSIONING PROTOCOL

## 9.1 COMMISSIONING PROTOCOL ambiente a1/a2/a3/a4/a5/a6/a7/a8

Date:	Device no.: (see rating plate)		
Installation company:			
Has the actual delivery pressure been checked?	<input type="checkbox"/> Yes <input type="checkbox"/> No		
<b>Negative pressures greater than 20-25 Pa can influence correct operation. The pane can become increasingly contaminated or noise can be intensified!</b>			
Test fire performed:	<input type="checkbox"/> Yes <input type="checkbox"/> No		
The fireplace operator has been instructed regarding operation and the instructions for assembly and use have been provided:			
Signatures:			
Installer	Stove Fitter	Owner	
Annual maintenance carried out:			
Type of work			
Name:			
Date:			
Signature			

**Caution: Keep in a safe place!** Store these instructions with valid and clearly dated proof of purchase and have the documents ready for our technicians in the event of service work.

## 9.2 COMMISSIONING PROTOCOL ambiente a4 H<sub>2</sub>O/a6 H<sub>2</sub>O

Date:	Device no.: (see rating plate)				
Address of heating system installation company:					
Stove fitter address:					
Heating system ventilated:	<input type="checkbox"/> Yes <input type="checkbox"/> No				
Operating pressure checked:	<input type="checkbox"/> Yes <input type="checkbox"/> No				
System tested for leaks:	<input type="checkbox"/> Yes <input type="checkbox"/> No				
All safety devices (Thermal discharge safety device, safety valve, membrane expansion vessel) checked:	<input type="checkbox"/> Yes <input type="checkbox"/> No				
Measure temperatures directly at the inlet and outlet of the stove and document:	Return flow temperature in °C				
	Flow temperature in °C				
Visual inspection of the heating system:	<input type="checkbox"/> Yes <input type="checkbox"/> No				
Function check executed:	<input type="checkbox"/> Yes <input type="checkbox"/> No				
Test fire performed:	<input type="checkbox"/> Yes <input type="checkbox"/> No				
Has the actual delivery pressure been checked?	<input type="checkbox"/> Yes <input type="checkbox"/> No				
<b>Negative pressures greater than 20-25 Pa can influence correct operation. The pane can become increasingly contaminated or noise can be intensified!</b>					
The fireplace operator has been instructed regarding operation and the instructions for assembly and use have been provided:					
Signatures:					
Installer	Stove Fitter	Owner			
Annual maintenance carried out:					
Type of task:					
Name:					
Date:					
Signature					

**Caution: Keep in a safe place!** Store these instructions with valid and clearly dated proof of purchase and have the documents ready for our technicians in the event of service work.

NOTES

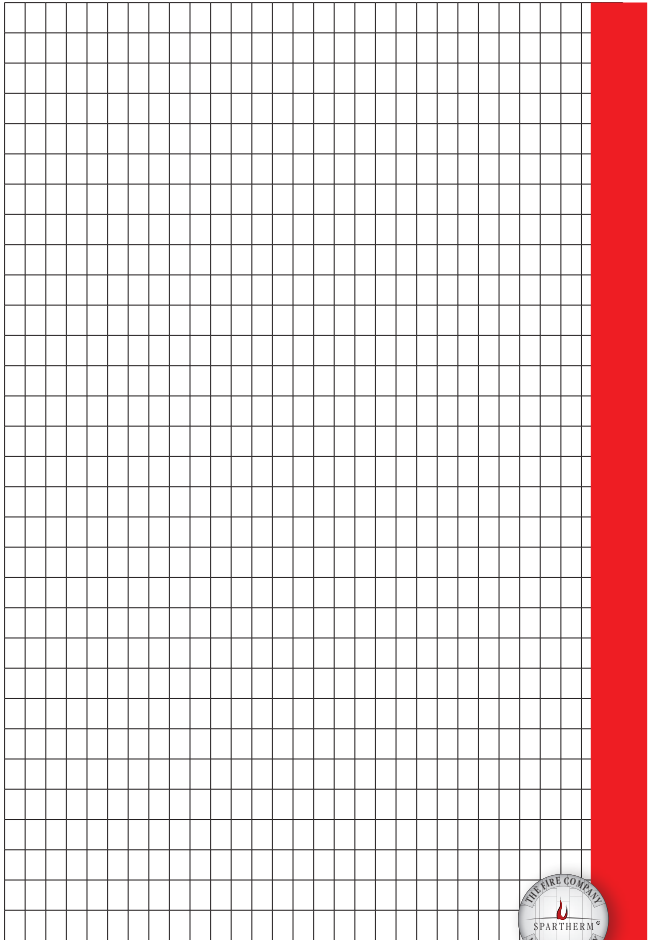
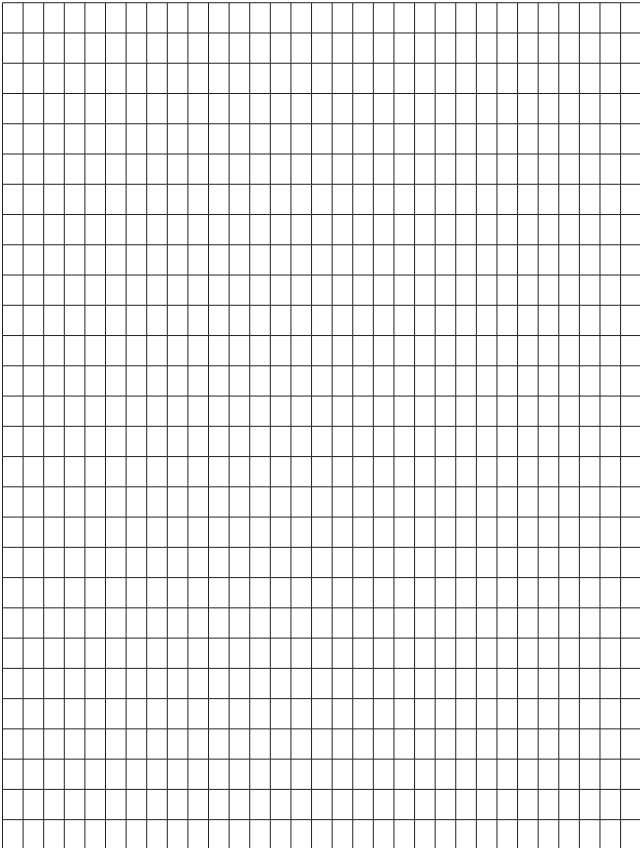

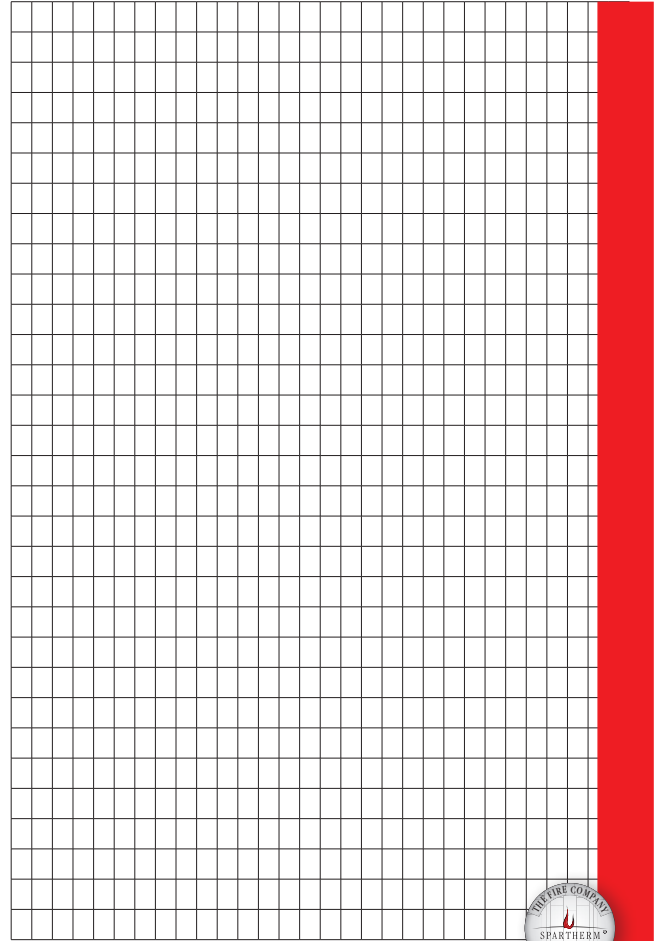
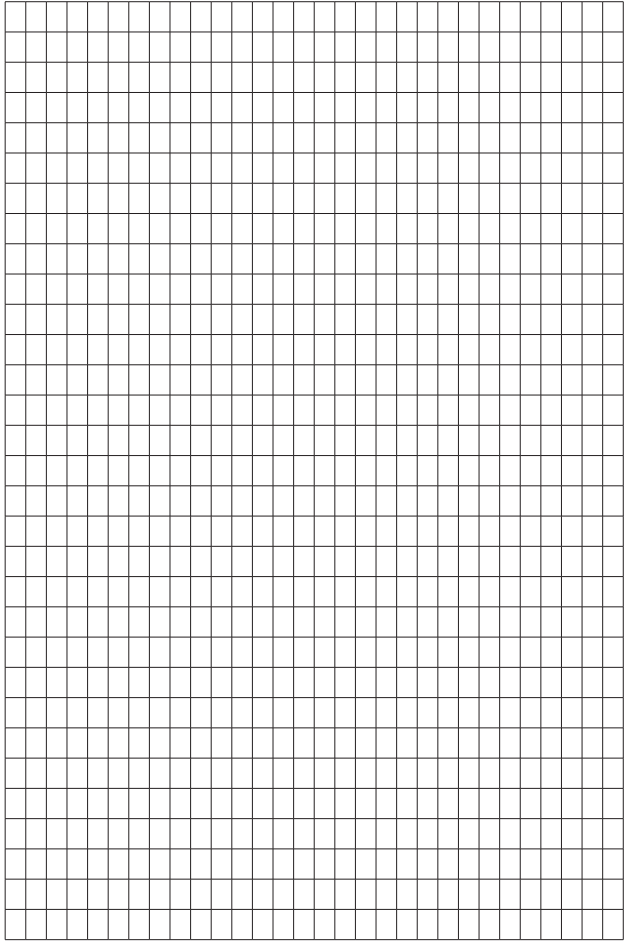



# SPARTHERM

The global brand for your lounge

Reg. no.:

Product inspected by:

Date:

\_\_\_\_ - \_\_\_\_ - \_\_\_\_  
Day Month Year

Your specialist dealer:



Spartherm Feuerungstechnik GmbH | Maschweg 38 | 49324 Melle | Germany | Tel.:  
+49 5422 9441-0 | [www.spartherm.com](http://www.spartherm.com)

Service hotline 0180 594 41 94

14 cents/minute incl. VAT from a German landline, max. 42 cents/minute incl. VAT.  
from a German mobile network