



Maestro 60 RCH

G20/G25/G25.3 (Natural gas), G30 (Butane) and G31 (Propane)



English



Store this document in a safe place



Content

| | |
|---|----|
| 1. Step-by-step installation plan | 4 |
| 2. Introduction | 5 |
| 3. CE declaration | 5 |
| 4. Technical data | 6 |
| 5. SAFETY | 7 |
| 5.1 General | 7 |
| 5.2 Regulations | 7 |
| 5.3 Safety instructions | 7 |
| 6. Preparation | 8 |
| 6.1 Unpacking | 8 |
| 6.2 Type of gas | 8 |
| 6.2.1 Gas type conversion | 8 |
| 6.3 Gas connection | 8 |
| 6.3.1 Gas hose for gas connection | 9 |
| 6.4 Electric connection | 9 |
| 6.5 Components appliance control | 10 |
| 7. Installation | 11 |
| 7.1 Placing the appliance | 11 |
| 7.2 Additional installation options of the construction frame | 12 |
| 7.3 Concentric system | 13 |
| 7.3.1 General | 13 |
| 7.3.2 Roof terminal (C31) | 15 |
| 7.3.3 Wall terminal (C11) | 18 |
| 7.3.4 Connection to an existing chimney | 21 |
| 7.4 Placing the chimney breast | 21 |
| 7.5 Placing the control hatch | 24 |
| 8. Appliance | 26 |
| 8.1 Glass panes | 26 |
| 8.1.1 Opening the glass pane | 26 |
| 8.1.2 Closing the glass pane | 27 |
| 8.1.3 Removing glass pane | 28 |
| 8.1.4 Reinstalling glass pane | 29 |
| 8.2 Adjusting the appliance | 30 |
| 8.2.1 Restrictor slide | 30 |
| 8.2.2 Air inlet guide | 31 |
| 8.3 Wood set | 32 |
| 8.3.1 Installing the wood set | 32 |
| 9. Control/operation | 41 |
| 9.1 Principle of ignition cycle | 42 |
| 9.2 Connecting the switch contact | 42 |
| 9.3 Connection extra power supply (max. 80W, 230VAC) | 43 |
| 9.4 Remote controls | 43 |
| 9.4.1 Black remote control for the user | 43 |
| 9.4.2 Orange remote control for the installer | 43 |

| | |
|--|----|
| 9.5 Alternative operation | 43 |
| 9.5.1 Wired | 44 |
| 9.5.2 Wireless | 45 |
| 9.5.2.1 Connection via 'modbus' protocol | 45 |
| 9.5.2.2 Control via application | 45 |
| 10. Final inspection | 46 |
| 10.1 Gas tightness | 46 |
| 10.2 Gas pressure/line-pressure | 46 |
| 10.3 Ignition main burner | 46 |
| 10.3.1 First ignition of the appliance after installation or adjustments | 46 |
| 10.3.2 Procedure for igniting the main burner | 47 |
| 10.4 Flame picture | 47 |
| 11. Delivery | 48 |
| 12. Maintenance | 49 |
| 12.1 Parts | 49 |
| Appendix 1: Malfunctions | 50 |

1. Step-by-step installation plan

The major steps of the installation are described below,
 Perform these steps and tick them once they have been performed correctly.

 Carefully read the installation manual before installing the appliance.

- Check that the correct type of appliance has been delivered (see table 4-1).
- Check that the gas type and gas pressure is correct on the location where the appliance is placed.
- Check that the supplied parts are present (see table 6-1).
- Check the appliance for damages.
- Make sure that the total installation complies with the applicable national, local and architectural regulations.
- Make sure that there is a gas tap present that is always accessible and meets the legal regulations.
- Ensure that the placement meets the applicable requirements concerning fire safety.
- Make sure that the configuration of the concentric system with roof or wall duct corresponds with the imposed requirements (see section 7.3).
- Make sure the chimney breast meets the fire safety requirements. (see section 7.4).
- Make sure the chimney breast meets the minimum dimensions (see section 7.4).
- Make sure the chimney breast is sufficiently ventilated (see section 7.4).
- Make sure that the control hatch with gas control is placed correctly (see section 7.5).
- Make sure that the restrictor slide and air inlet guides are correctly adjusted (see section 8.2).
- Ensure a correctly placed wood, pebble set or broken glass set with accessories (see section 8.3).
- Make sure the remote control is made ready for use (see section 9.4).
- Check all gas connections for gas tightness (see section 10.1).
- Make sure that the appliance is first ignited without the glass pane (see section 10.3.1).
- Ensure a cleaned glass pane in accordance with the instruction, before the atmospheric fire is ignited with the glass pane for the first time (see chapter 12).
- Check the appliance with installed glass pane for a correct ignition and a correct flame transfer of the main burner(s) when igniting for the first time (see section 10/3/2).
- Familiarise the user with the appliance (see chapter 11).

The appliance is now (after the above-mentioned steps) ready for use and the consumer is familiar with the possibilities for using the appliance.

2. Introduction

DRU, a manufacturer of gas-fired heating appliances, develops and produces products that comply with the highest possible quality, performance and safety requirements. This appliance has a CE label, which means that it complies with the essential requirements of the European Gas Appliance Directive. The appliance is supplied with an installation manual and a user manual. Installation and maintenance of the appliance should be performed by a professional certified expert with a proven knowledge and demonstrable competence in this field.

A professional expert takes all technical aspects such as heat output, gas connection and electricity into account, as well as the flue gas discharge requirements. The information in this installation manual will ensure the appliance is installed in such a way that it will function properly and safely. If the installation instruction is not clear, national/local regulations must be observed.

This manual discusses the installation of the appliance and the regulations that apply to the installation. In addition, the appliance's technical data are shown and information is provided about maintenance, possible malfunctions that might occur and their possible causes.

Fully and carefully read and use this installation manual, before installing the appliance. When using the DRU Powervent system* or DRU CM system*, the accompanying installation manual should also be read completely and carefully, before installation work begins.

The following symbols are used in the manual to indicate important information:

- Work to be performed
 - 💡 Suggestions and recommendations
 - ⚠ You will need these instructions to prevent problems that might occur during installation and/or use.
 - ⚠ You need these instructions to prevent fire, personal injury or other serious damages.
- After final delivery, the manuals should be handed over to the user.

3. CE declaration

DRU declares that company internal measures guarantee that appliances produced by DRU meet the essential requirements and guidelines of the regulation concerning gas-fired appliances and the accompanying standards. This declaration loses its validity if changes are made to the appliance without written permission from DRU. The instructions in the manuals must also be observed at all times. A copy of the CE test certificate can be downloaded via www.druservice.com.

| | |
|--------------------------------|---|
| Product: | Gas-fired heating appliance |
| Type: | Maestro 60 RCH |
| Product identification number: | 0063CU3479 |
| Conformity assessment body: | Kiwa Netherlands B.V. (0063) Wilmersdorf 50 Postbus 137 7300 AC, Apeldoorn |
| Regulations: | (EU) 2016/426, (EU) 2015/1188 |
| Directives: | 2014/35/EU, 2014/30/EU |
| Standards: | EN 613:2000, EN 613:2000/A1:2003, EN 613:2000/PrA2:2002 EN 60335-1:2012, EN 60335-2-102:2016, EN 55014-1:2007 EN 55014-2:2015, EN 61000-3-2:2014, EN 61000-3-3:2013 |

DRU Verwarming B.V.
Postbus 1021, NL-6920 BA Duiven
Ratio 8, NL-6921 RW Duiven
www.drufire.com

Duiven, 29-08-2019



R.P. Zantinge, Managing director

4. Technical data

Check the technical data based on the table below.

| Table 4-1: Technical data | | | | | | |
|--|--|----------------------------------|----------------------------------|----------------------------------|----------------------------------|-------------------------------|
| Model identifier(s) | Maestro 60 RCH | | | | | |
| Type of appliance | Built-in | | | | | |
| Combustion | Closed combustion | | | | | |
| Type | C11, C31, C91, C12, C32***** | | | | | |
| Categorie | I _{2E} , I _{2E+} , I _{2EK} , I _{2ELL} , I _{2H} , I _{3B} , I _{3P} , II _{2E3B/P} , II _{2EK3B/P} , II _{2H3B/P} , II _{2H3P} | | | | | |
| Concentric appliance connection | 200/130 | | | | | |
| Applicable concentric systems | DRU LAS ES-I 200/130, DRU LAS ES-E 200/150/100, DRU LAS AG-I 150/100, DRU LAS ES-I 150/100, DRU PV-I 100/60 | | | | | |
| Flame protection version | Separated ignition / ionization plugs | | | | | |
| Pressure equalisation | Yes | | | | | |
| Max. temp. outer tube concentric system | 150°C | | | | | |
| Radiation range safe distance (front/side) | 700 mm / 500 mm | | | | | |
| Ventilation hole chimney breast | V-in: 80 cm ² (LED; 2x 80 cm ²) /V-out: 200 cm ² | | | | | |
| Gastype: | Symbol | G25/G25.3* | G20 | G30 | G31 | Unit |
| Indirect heating functionality | | No | No | No | No | |
| Direct heat output | | 6,8 | 7,2 | 8,5 | 7,3 | kW |
| Indirect heat output | | - | - | - | - | kW |
| Space heating emissions NO _x | | 96,8 | 107,2 | 80,4 | 69,4 | mg/kWh _{input} (GCV) |
| Heat output | | | | | | |
| Nominal heat output | P _{nom} | 6,8 | 7,2 | 8,5 | 7,3 | kW |
| Minimum heat output (indicative) | P _{min} | 1,6 | 1,9 | 1,2 | 1,1 | kW |
| Technical data | | | | | | |
| Nominal heat input (Hs) | | 9,3 | 9,8 | 11,0 | 9,7 | kW |
| Nominal heat input (Hi) | | 8,4 | 8,8 | 10,2 | 8,9 | kW |
| Consumption max | | 1001 | 931 | 311 | 359 | L/h |
| Consumption min | | 269 | 271 | 50 | 60 | L/h |
| Burner pressure max | | 16,7 | 13,5 | 26,5 | 26,6 | mbar |
| Burner pressure min | | 6,2 | 4,9 | 8,4 | 9,0 | mbar |
| Main burner injector | | 1x Ø1,65 1x Ø1,40 1x Ø1,50 | 1x Ø1,65 1x Ø1,40 1x Ø1,50 | 1x Ø1,10 1x Ø0,90 1x Ø1,05 | 1x Ø1,10 1x Ø0,90 1x Ø1,05 | mm |
| Low setting injector | | A**** | A**** | A**** | A**** | mm |
| Efficiency class (EN613) | | 1 | 1 | 1 | 1 | |
| Useful efficiency (NCV)** | | | | | | |
| Useful efficiency at nominal heat output | η _{th,nom} | 92,5 | 94,3 | 94,6 | 93,9 | % |
| Useful efficiency at minimum heat output (indicative) | η _{th,min} | 91,0 | 91,3 | 91,8 | 91,9 | % |
| Auxiliary electricity consumption | | | | | | |
| At nominal heat output | e _{l,max} | 0,0236 | 0,0236 | 0,0236 | 0,0236 | kW |
| At nominal heat output | e _{l,min} | 0,0125 | 0,0125 | 0,0125 | 0,0125 | kW |
| In standby mode | e _{l,SB} | 0,0026 | 0,0026 | 0,0026 | 0,0026 | kW |
| Permanent pilot flame power requirement | | | | | | |
| Pilot flame power requirement (if applicable) | P _{pilot} | - | - | - | - | kW |
| Energy efficiency | | | | | | |
| Energy efficiency index | EEl | 92 | 94 | 94 | 93 | |
| Energy efficiency class | | A | A | A | A | |
| Type of heat output / room temperature control | | | | | | |
| Single stage heat output, no room temperature control | | | | | | No |
| Two or more manual stages, no room temperature control | | | | | | No |
| With mechanic thermostat room temperature control | | | | | | No |
| With electronic room temperature control | | | | | | Yes |
| With electronic room temperature control plus day timer | | | | | | Yes |
| With electronic room temperature control plus week timer | | | | | | Yes |
| Other control options | | | | | | |
| Room temperature control, with presence detection | | | | | | Yes*** |
| Room temperature control, with open window detection | | | | | | Yes*** |
| With distance controle option | | | | | | Yes |

* This appliance is suitable for G25.3 with the composition according NTA 8837. ** System efficiency. *** To be used by means of home automation. **** Adjusting screw. *****Categories C12 and C32 only in combination with DRU PV-1 100/60 (PowerVent®).

5. SAFETY

5.1 General

- ⚠ - Observe the generally applicable regulations and precautions/safety instructions in this manual.
- First check that the technical execution of the appliance to be installed is correct (see table 4-1).
- Read this manual carefully to ensure the proper and safe installation of the appliance.
- Observe the regulations/instructions in this manual.

5.2 Regulations

Please install the appliance in accordance with the applicable national, local and constructional (installation) regulations.

5.3 Safety instructions

Carefully observe the following precautions/safety instructions:

- ⚠ The appliance may only be installed and maintained by recognised installers who are skilled in the field of gas heating and electricity.
- ⚠ Do not make any changes to the appliance.
- ⚠ When installing a built-in appliance:
 - Use non-combustible and heat-resistant materials for the chimney breast, including the top of the chimney breast and the material in the chimney breast, such as the floor under the appliance and the back wall against which the appliance will be placed. For this you can use both sheet material and stone-like materials.
 - Take sufficient measures to prevent temperatures of a wall behind the chimney breast becoming too high, including the materials and/or objects behind the wall.
 - Take the minimum required internal dimensions of the chimney breast into account. These are for the benefit of safety and for the prevention of excess heat accumulation in the chimney breast.
 - Vent the chimney breast by means of the ventilation holes (see table 4-1). These are essential for ensuring safety and for the prevention of excess heat accumulation in the chimney breast.
 - Use heat resistant electrical connectors.
 - Place heat-resistant electrical wiring away from the appliance and as low as possible in the chimney breast. This has to do with the temperature development in the chimney breast.
 - Only use the flue gas discharge / combustion air supply system (concentric system) supplied by DRU.
- ⚠ When installing a free-standing appliance: place the appliance at the indicated minimum distance from the back wall, as indicated further down in the text.
- ⚠ Do not cover the appliance and/or do not wrap it in an insulation blanket or any other material.
- ⚠ Keep combustible objects and/or materials outside the appliance's radiation range (see table 4-1).
- ⚠ Only use the accompanying set, such as the wood or pebble set, and place it exactly as described.
- ⚠ Leave space around the ionisation pin and spark electrode and never place glow material around these pins.
- ⚠ Make sure there is no dirt in gas pipes and connections.
- ⚠ Place a gas tap in accordance with applicable regulations.
- ⚠ Check the complete installation for gas tightness prior to commissioning.
- ⚠ Prevent the explosion hatch(es) on the top of the appliance (if present) from getting clogged and check that they properly fit on the sealing surface, before the appliance is built in.
- ⚠ Do not ignite the appliance until it is fully installed when it comes to the gas connections, discharge system and electrical components.
- ⚠ Do not use the appliance when a pane is broken and/or cracked, until it has been replaced.
- ⚠ The appliance was designed for atmospheric and heating purposes. This means that all visible surfaces, including the glass pane, can become hotter than 100°C. It is recommended to always place a protective grating in front of the appliance when there are children, elderly people or handicapped persons in the same room as the appliance. If it is possible that vulnerable people are regularly present in the room with no supervision, a fixed guard should be mounted around the appliance.

6. Preparation

6.1 Unpacking

Note the following items when removing the packaging:

- Remove all packaging materials.
- Remove all supplied components in, on and/or at the appliance.
- Check the appliance and accessories for damages (during transport).
- If necessary, contact your supplier.
- Never install an appliance that is damaged!
- Remove any screws that are used to fix the appliance to a platform or pallet.
- ⚠ The glass pane(s) is/are made of a ceramic material. Very small irregularities in the glass panes cannot be avoided, but are within the required quality standards.
- ⚠ Keep plastic bags away from children.

Table 6-1 indicates which components should be available after removing the packaging.

- Contact the supplier if you find that not all components have been supplied.
- Packaging must be disposed of in accordance with the regulations.

Table 6-1: Parts included with the delivery

| Part | Number |
|---|--------|
| Installation manual | 1x |
| User manual | 1x |
| Wood set (including: chips, vermiculite and ash) | 1x |
| LED glow rocks (if applicable) | 1x |
| Glow material | 1x |
| Restrictor slide | 1x |
| Air inlet guide 2 | 1x |
| Remote control | 1x |
| Mains cable | 1x |
| Control hatch | 1x |
| Back-up self-tapping screw | nx |
| Key bolt M8 (including: Hexagonal nut M8 and Washer M8) | 4x |
| Compression fitting 15 mm x G3/8" | 1x |
| Socket spanner 8 mm | 1x |

6.2 Type of gas

The data plate indicates for which type of gas, gas pressure and for which country this appliance is intended.

The data plate can be found on the appliance or can be attached to a chain to which it should remain attached.

- ⚠ Check whether the appliance is suitable for the type of gas and the gas pressure used at the location.

6.2.1 Gas type conversion

In order to convert this appliance to a different type of gas, please contact DRU's service department and ask for the possibilities. The conversion should be performed by a recognised gas installer.

6.3 Gas connection

Place a gas tap in the gas pipe in accordance with the applicable regulations. The gas connection on the gas control is located next to the receiver (fig. 6-2 (G_{in})).

- ⚠ - Make sure there is no dirt in the gas pipes and connections.
- No soldering may take place at the flexible gas hose(s), as this could cause leaks.

The following requirements apply to the gas connection:

- Use a gas pipe with the correct dimensions, so that no pressure loss can occur.
- The gas tap must be approved (in the EU this will be the CE mark).
- You should always be able to reach the gas tap.

6.3.1 Gas hose for gas connection

In many cases, an EN14800-compliant gas hose for a gas connection can be ordered together with the appliance. The gas hose is mounted to the appliance and has been checked for leak-tightness. This gas hose is available in different lengths.

⚠ Take the following into account when installing the gas connection and the appliance (see fig. 6-1):

- The gas connection must always be accessible to be able to shut off the gas supply.
- The gas connection may only be mounted vertically, so that the gas hose can be connected vertically at the bottom.
- The gas connection is permitted in a zone (blue hatched area in fig. 6-1). To the left and right of the appliance to a height of 30 cm above the bottom side of the appliance (the bottom side is the end of the adjustable feet holder, without the feet). Under the appliance in the area between the legs.
- The gas connection and gas hose should not be placed behind the appliance.
- The gas hose may not get above the bottom side of the appliance (the bottom side is the end of the foot without the adjustable feet)
- The minimum bend radius of the hose is 40 mm.
- The hose should be placed as low as possible, must have a minimum distance from the appliance of 20 mm and, if possible, should not be placed under the burner.
- The entrance of the gas control in which the hose is mounted faces the appliance. Due to the bend radius, the chimney breast width becomes larger on the side of the control hatch. The minimal depth of the control hatch is 270 mm.

6.4 Electric connection

In case of an electrical connection of 230 Volts, always provide sufficient earthing. Place this electrical connection away from the appliance, as low as possible in the chimney breast. Make sure the electrical connection is within reach. This has to do with the temperature development in the chimney breast.

⚠ Make sure that it is easy to disconnect the appliance from the power supply after installation: By disconnecting the plug or by means of a 2-core switch installed by a recognised installer in accordance with current regulations.

- ⚠ - Protect the gas control and electric components, hereafter referred to as the gas control, against building dust and moisture!
- In the case of appliances made with the CM system*, observe the instructions in the supplied manual for connecting the receiver and control panel.

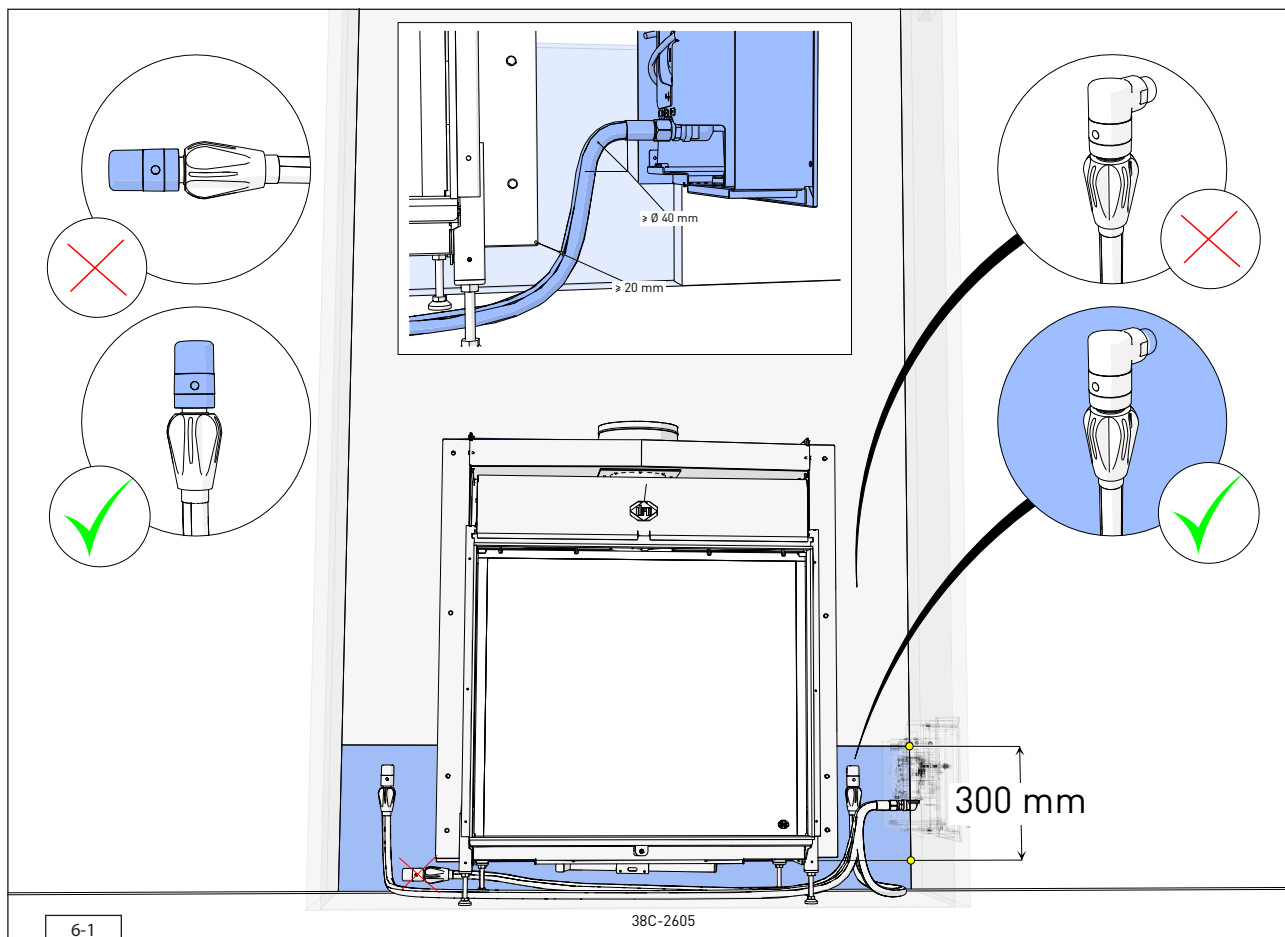

6.5 Components appliance control

This section states the components that are used to control the appliance (see fig. 6-2).

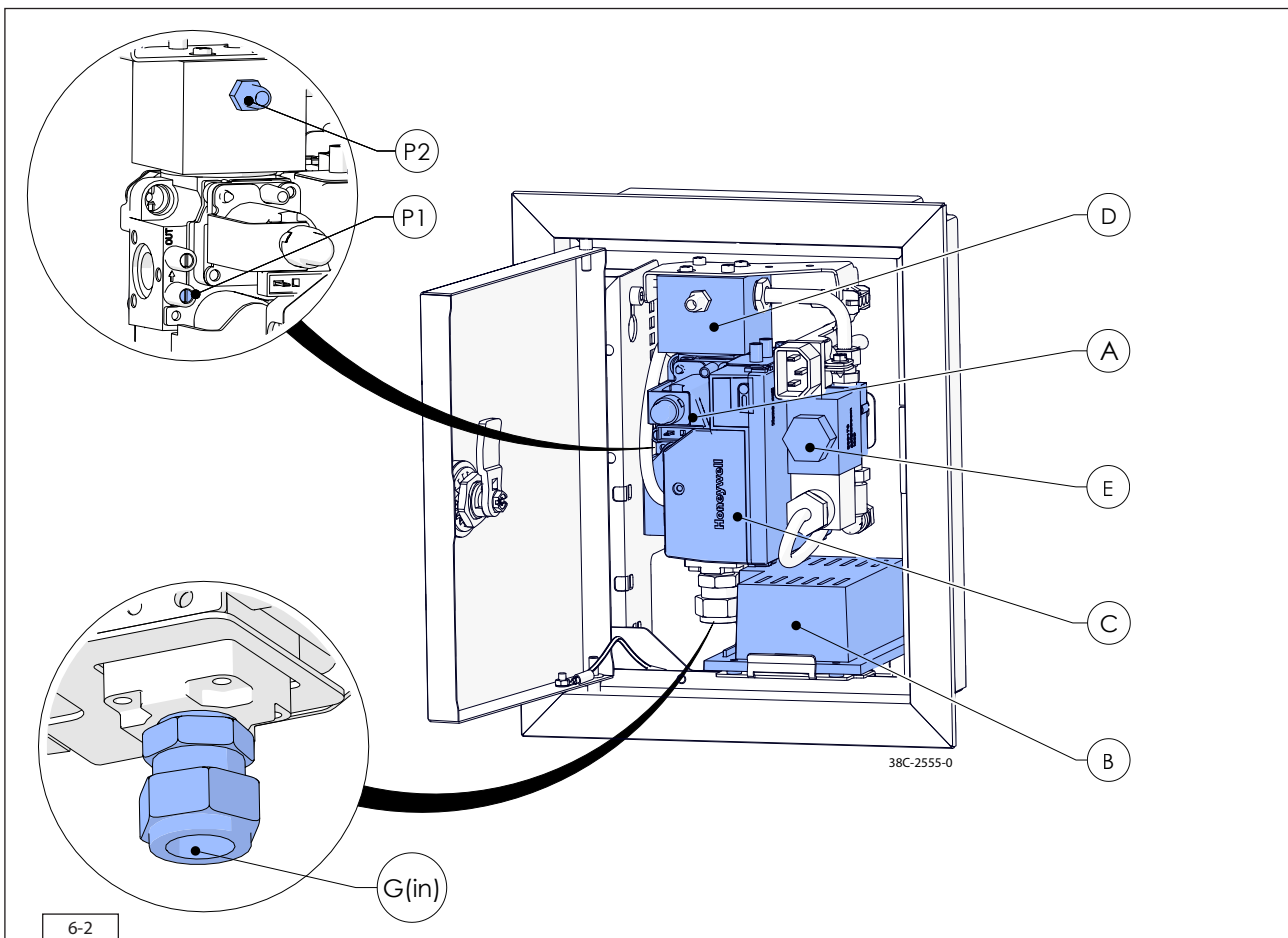

Legend:

- A = Gas control; controls the gas to the burners
- B = Receiver; communicates with the transmitter
- C = Processor (ESYS); controls the gas control
- D = Distribution block; connection of the burners
- E = Valve 2nd burner; opens and closes the gas supply to the 2nd burner (if applicable)
- P1 = Pressure gauge nipple 1; line-pressure
- P2 = Pressure gauge nipple 2; burner pressure
- G (IN) = Gas connection; connection from the gas control to the gas network

7. Installation

7.1 Placing the appliance

Separate sub-sections describe different ways of placing the appliance. The general description below for placing the appliance applies to all these sub-sections:

- Place the appliance where it will be installed and observe the following:
 - ⚠ - The construction dimensions of the appliance (see fig. 7-1).
 - The minimum chimney breast dimensions (see section 7-4).
 - The length of the cables and pipes (see section 7-4).
 - Place the appliance in front of a heat-resistant and non combustible wall and on a heat-resistant and non-flammable floor. The wall brackets on a built-in appliance ensure that the minimum distance to the wall is maintained (see fig. 7-1 (A)).
 - Take sufficient measures to prevent temperatures of a possible wall behind the chimney breast becoming too high, including the materials and/or objects behind the wall.
 - Make sure there are no combustible objects or materials within the radiation range (see table 4-1 and fig. 7-3) of the fire.
 - Place the concentric system in such a way that no fire hazard can ever be created (see section 7.12).
 - Do not cover the appliance and/or do not wrap it in an insulation blanket or any other material.
 - Make sure that the appliance to be installed has a stable position. Fasten possible extending legs with the self-tapping screws.
- Set the height of the appliance using the adjustable feet and level the appliance.
- Attach the appliance to the wall using wall brackets (see fig. 7-1 (A)).
- Loosen the bracket with the gas control by loosening the self-tapping screws and screw the self-tapping screws back in the appliance.
- Place the bracket with the gas control, together with the wiring of the ignition/ionization cable(s), the flexible gas hose(s) and the data plate with chain in the direction of the control hatch (see section 7.5).
- ⚠ - Do not lay the cables of the ionisation and ignition pins along metal parts, wiring and other components.
- The data plate must remain attached to the appliance with the chain.

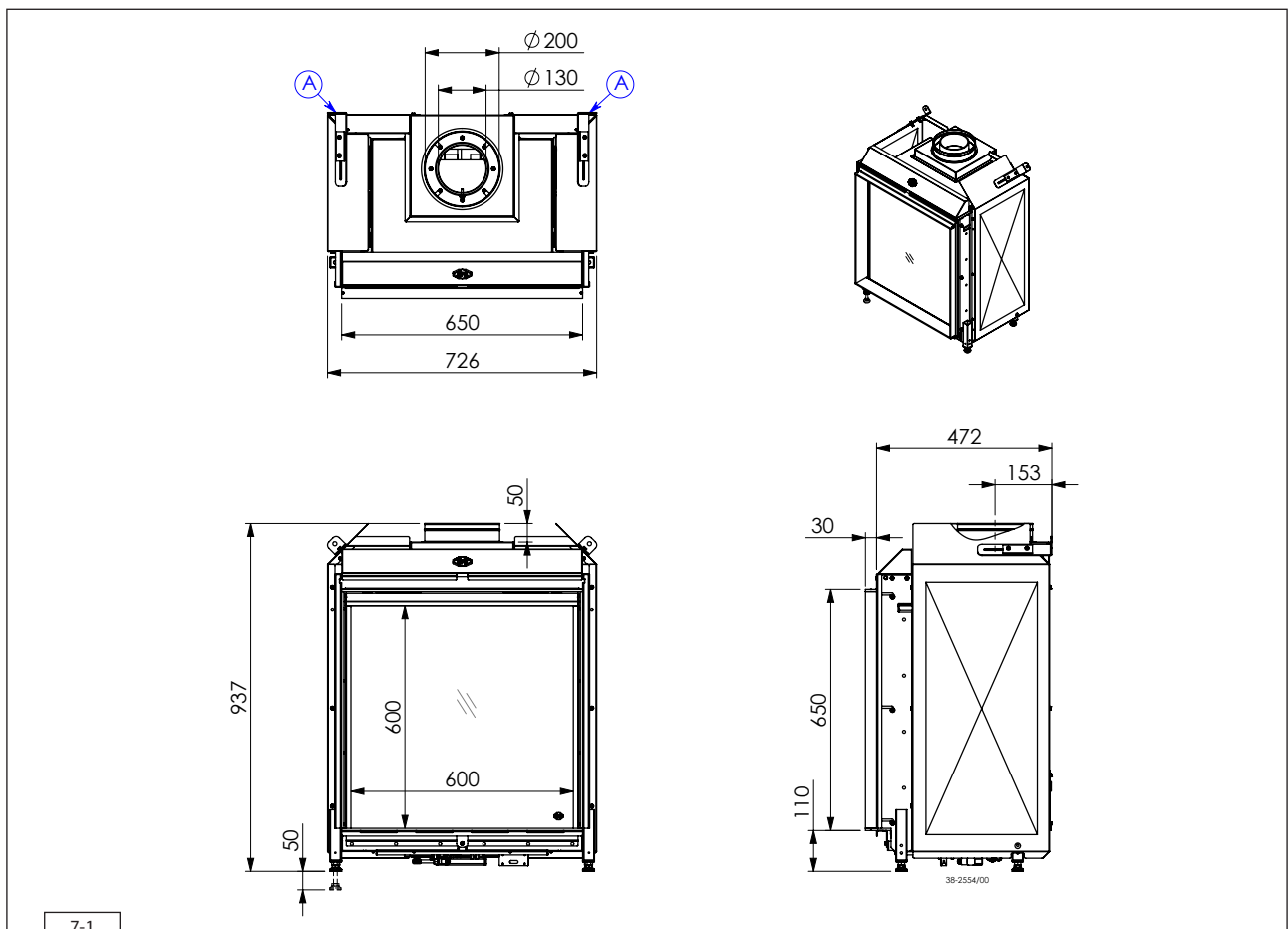

7.2 Additional installation options of the construction frame

The construction frame of this appliance can be adjusted from the "4S version" to the "3S version" (see fig. 7-2). The 3S version allows you to fit the glass pane against the floor or platform.

- ⚠ When using the 3S construction frame, the platform or floor in front of and next to the appliance has to be made with inflammable material (see section 7.4)
- ⚠ No other information can be provided, nor can responsibility be accepted for the way in which floor covering or other materials are influenced by the use of this appliance (e.g. the 'working' of a wooden floor). This despite adhering to the minimum required distance to non combustible floor covering or other materials.

When choosing the 3S version, the lower strip of the construction frame has to be removed before this appliance is installed.

Proceed as follows:

- Remove the Allen screws with an Allen key (1).
- Hold the strip and unscrew the self-tapping screw.
- Remove the strip (2).

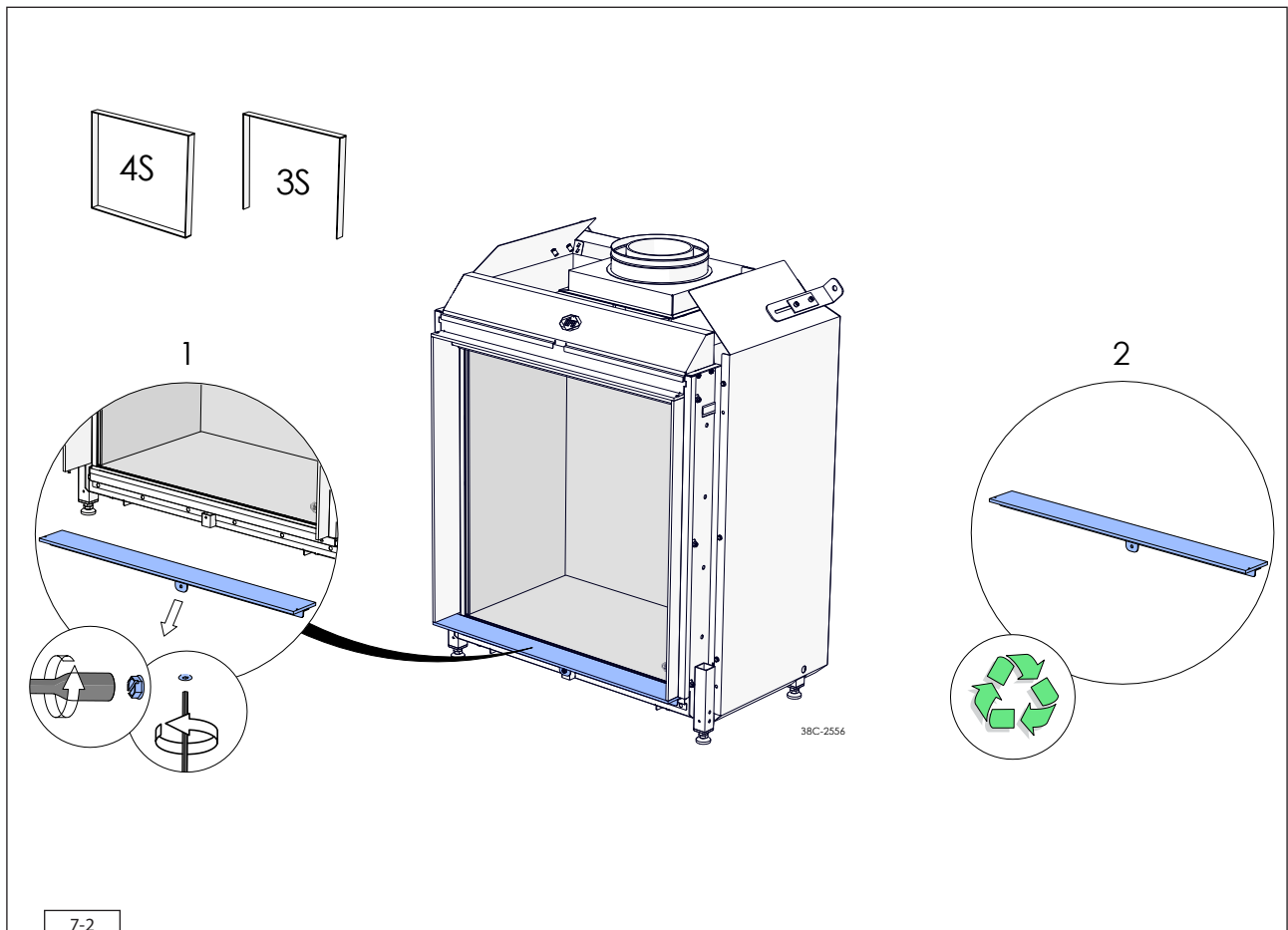

7.3 Concentric system

7.3.1 General

The appliance is connected to a flue gas discharge / combustion air supply system delivered by DRU, hereafter referred to as the concentric system. DRU has different concentric systems in its range.

In the case of a concentric system, the inner tube is used as flue gas discharge. The combustion air is supplied by the outer tube. As a result, the latter always has a relatively low temperature. For the maximum temperature of the outer tube, see the technical data in table 4-1. The concentric system has been tested in combination with the appliance. Other concentric systems are not permitted.

See the table below for the different concentric systems of DRU and their application:

| Table 7-1: Concentric systems and their application | | |
|---|-------------------------------|--|
| System | Permitted for this appliance. | Remarks |
| DRU LAS AG-I 150/100 | Yes | Alu-galva tubes for use inside the building*. Diameter Ø150/100 mm. Cannot be combined with the SS systems. |
| DRU LAS ES-I 150/100 | Yes | SS tubes for use inside the building*. Diameter Ø150/100 mm. Using an SS adapter, it is possible to construct further with the insulated LAS ES-E 200/150/100 system. |
| DRU LAS ES-I 200/130 | Yes | SS tubes for use inside the building*. Diameter Ø 200/130. Using an SS adapter, if permitted, it is possible to construct further with LAS-ES-I 150/100. |
| DRU LAS ES-E 200/150/100 | Yes | Insulated SS tubes. Discharge diameter Ø150/100. External diameter Ø 200 mm. Intended for use inside or outside building for placement in, for example, timber frame construction, execute with 0 mm distance along combustible material etc. It is not possible to continue building with an SS adapter with LAS ES-I 150/100. |
| DRU PV-I 100/60 | Yes | Optional discharge system with fan for discharge up to approx. 60 metres long. |

* With the exception of the components intended for that purpose, such as roof and wall terminals.

The diameter of the concentric system appliance connection can be found in table 4-1. By means of natural draft, the flue gases are discharged to the outside, this can be achieved by means of a wall terminal (C11) or a roof terminal (C31). If necessary, an existing chimney can be used (C91, see section 7.3.5).

In addition, if combined with PowerVent® (C12, C32), it is possible in many cases to discharge the flue gases with a smaller diameter (DRU PV-I 100/60).

- Only use the concentric system supplied by DRU This system has been tested in combination with the appliance. DRU cannot guarantee a proper and safe operation of other systems and does not accept any responsibility or liability for this.
- Use a chimney kit for making a connection to the chimney; this can be supplied by DRU.
- For terminals, observe the information in table 7-2.

| Table 7-2: Terminals | | | | |
|---|-----------------------------|---|--------------------------|--|
| System | Hole diameter and execution | | | |
| | Combustible material | | Non combustible material | |
| | Ø (mm) | Notes | Ø (mm) | Note |
| DRU LAS AG-1 150/100 DRU LAS ES-I 150/100 | ≥250 | The terminal hole may be covered with a rosette made of non-combustible material. This terminal hole must be ventilated. A 2 mm wide ventilation opening around the tube is sufficient. The space between the tube and the combustible material may not be filled with insulation material. | ≥154 | Make terminal hole all around 2mm larger than the diameter of the concentric system to prevent "ticking" and such like. The terminal hole does not require ventilation. |
| DRU LAS ES-I 200/130 | ≥300 | | ≥204 | |
| DRU PV-I 100/60 (also see: installation manuel PowerVent®) | ≥200 | | ≥104 | |
| DRU LAS ES-E 200/150/100 | ≥204 | The distance from combustible material may be 0 mm. The terminal hole does not require ventilation. If a clip binding is placed in a terminal hole, a hole diameter of Ø230 mm must be maintained. | ≥204 | Make terminal hole all around 2mm larger than the diameter of the concentric system to prevent "ticking" and such like. The terminal hole does not require ventilation. If a clip binding is placed in a terminal hole, a hole diameter of Ø230 mm must be maintained. |

- ⚠ - Maintain a distance of at least 50 mm between the outside of the concentric system and the walls and/or ceiling. If the system is built in (for instance) a cove, it should be made with non combustible, heat-resistant material all around it. This does not apply to the insulated concentric system (DRU LAS ES-E 200/150/100).
- Some heat-resistant insulation materials contain volatile components that will spread an unpleasant smell for a prolonged time; these are not suitable.

The concentric system is constructed from (the flue spigot of) the appliance.

If, due to constructional circumstances, the concentric system is placed first, it is possible to connect the appliance by means of a telescopic pipe piece.

Place the concentric system as follows:

- Build the system up from (the flue spigot of) the appliance.
- Connect the concentric pipe pieces and, if necessary, the bend(s).
- Apply a clip binding with silicon sealing ring on each connection (does not apply to DRU LAS ES-E 200/150/100, here the sealing ring is inside the tube).
- Use a sheet metal screw to fix the clip binding to the pipe on locations that cannot be reached after installation.
- Attach the concentric system with sufficient fastening brackets, so that the weight is not resting on the appliance. Observe the following;
 - Place the first fastening bracket 0.5 metre from the appliance, at the most.
 - Place a fastening bracket maximum 0.1 metre from each bend, if the bends are more than 0.25 metre away from each other. If two bends are closer to one another than 0.25 metre, 1 fastening bracket between these bends will be sufficient.
 - At least every 1 metre, place a fastening bracket at slanted and horizontal sections.
 - At least every 2 metres, place a fastening bracket at vertical sections.
- Fasten a roof terminal with anchor cables, if it protrudes more than 1,5 metres above the terminal.
- Determine the remaining length for the wall or roof terminal and cut it to size, make sure the correct insertion length is maintained.
- Place the wall terminal with the (groove/folded) seam at the top. Attach the wall terminal from the outside by means of four screws.

7.3.2 Roof terminal (C31)

The roof terminal can end in a sloping and a flat roof.

The roof terminal can be supplied with an adhesive plate for a flat roof or with a universally adjustable tile for a sloping roof.

When using a roof terminal (C31), the following applies:

The construction of the chosen system has to be allowed. The working method below indicates how the permissibility is determined of a concentric system when using a roof terminal.

- Count the number of 45° and 90° bends required (15° and 30° bends are also allowed; these are not counted).
- Count the total number of whole metres of horizontal pipe length.
- Count the total number of metres of vertical and/or sloping pipe length (roof terminal excluded).
- Find the number of required bends and the total horizontal pipe length (see table 7-3, columns 1 and 2).
- Find the required total vertical and/or sloping pipe length (see table 7-3, row 1).
- A box with a letter means that the chosen concentric system is permitted.
- Determine the adjustment of the appliance (see table 7-4).
- Adjust the appliance correctly with, for instance, a restrictor slide and an air inlet guide (see section 8.2).

| Table 7-3: Determination of the permissibility of a concentric system with roof terminal | | | | | | | | | | | | | |
|--|--|--|---|---|---|---|---|---|---|---|----|----|----|
| G20/G25/G25.3 G30/G31 | Total number of metres horizontal pipe length | Total number of metres vertical and/or sloping pipe length | | | | | | | | | | | |
| | | 1 | 2 | 3 | 4 | 5 | 6 | 7 | 8 | 9 | 10 | 11 | 12 |
| No bends | 0 | B | B | B | C | C | C | C | C | D | D | D | D |
| 2 bends | 0 | A | A | B | B | B | C | C | C | C | C | D | D |
| | 1 | A | A | A | B | B | B | C | C | C | C | C | |
| | 2 | A | A | A | A | B | B | B | C | C | C | | |
| | 3 | A | A | A | A | A | B | B | B | C | | | |
| | 4 | A | A | A | A | A | A | B | B | | | | |
| 3 bends | 0 | A | A | A | B | B | B | C | C | C | C | C | D |
| | 1 | A | A | A | A | B | B | B | C | C | C | C | |
| | 2 | A | A | A | A | A | B | B | B | C | C | | |
| | 3 | A | A | A | A | A | A | B | B | B | | | |
| | 4 | A | A | A | A | A | A | A | B | | | | |
| 4 bends | 0 | A | A | A | A | B | B | B | C | C | C | C | C |
| | 1 | A | A | A | A | A | B | B | B | C | C | C | |
| | 2 | A | A | A | A | A | A | B | B | B | C | | |
| | 3 | A | A | A | A | A | A | A | B | B | | | |
| | 4 | | A | A | A | A | A | A | A | | | | |
| 5 bends | - | | | A | A | A | A | A | | | | | |

■ Situation is not permissible. There are many more possibilities in combination with the DRU PowerVent system (DRU PV-I 100/60) (see PowerVent installation manual).

| Table 7-4: Conditions for setting the appliance when using a roof terminal | | | |
|--|-----------------|------------------|-----------------------------------|
| G20/G25/G25.3/G30/G31 | | | |
| Situation | Air inlet guide | Restrictor slide | Restrictor slide (Distance in mm) |
| A | NO | NO | - |
| B | YES (1)* | YES | 47 (B)** |
| C | YES (2)* | YES | 47 (C)** |
| D | YES (2)* | YES | 40 (D)** |

* This number must agree with the number on the air inlet guide.

** Adjust the restrictor slide to match the associated letter on the restrictor slide.

- △ For roof terminal: install a connection piece reducing the concentric system with a diameter of 200/130 mm to a diameter of 150/100 mm directly onto the appliance. Then place the first metre of the concentric system vertically, after which bends are permitted. Install the concentric system with a diameter of 150/100 mm throughout. Install the concentric system using stainless steel or aluminium/galvanised flue piping throughout.

7.3.3 Wall terminal (C11)

When using a wall terminal (C11), the following applies:

The construction of the chosen system has to be allowed.

- Check that the vertical pipe length falls between the minimum and maximum lengths (see table 7-5).
- Check that the horizontal pipe length (wall terminal excluded) falls within the minimum and maximum length (see table 7-5).
- 💡 In the horizontal section, 1 bend of 90° may be included. This bend counts for 2 metres. This means that the maximum allowed length is reduced by 2 metres. A 45° bend counts for 1 metre.
- Determine the correct adjustment of the appliance (see table 7-5).
- Adjust the appliance correctly with, for instance, a restrictor slide and an air inlet guide (see section 8.2).

The rosette of the wall terminal is too small to seal the opening in case of passage through combustible material. That is why a heat-resistant intermediate plate of sufficient size should first be mounted to the wall. Then, the rosette is mounted on the intermediate sheet.

- ⚠ When using a wall terminal, place the terminal with a downward slope of 1 cm / metre towards the outside, in order to prevent rain water from raining in.

Table 7-5a

| Setting | Apply |
|---|-------|
| Air inlet guide | ✘ |
| Restrictor slide | ✘ |
| <p>- Only use a 200/130 mm concentric system, including wall terminal.</p> <p>- In the case of this configuration, an unpainted stainless steel wall terminal must be used..</p> <p>- Factory setting: Air inlet guide 1 mounted, air inlet guide 2 and restrictor slide are supplied separately.</p> | |

Table 7-5b

| Setting | Apply |
|---|-------|
| Air inlet guide | ✘ |
| Restrictor slide | ✘ |
| <p>- Only use a 200/130 mm concentric system, including wall terminal.</p> <p>- Factory setting: Air inlet guide 1 mounted, air inlet guide 2 and restrictor slide are supplied separately.</p> | |

Table 7-5c

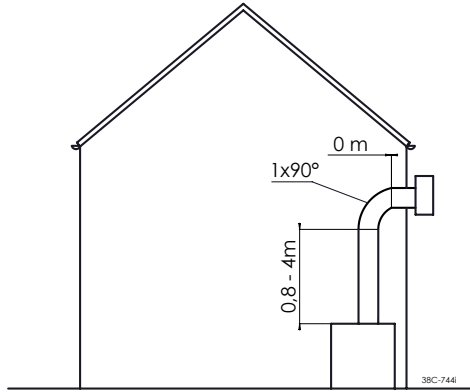

| Setting | Apply |
|------------------|-------|
| Air inlet guide | v (1) |
| Restrictor slide | x |

- Only use a 200/130 mm concentric system, including wall terminal.
 - Factory setting: Air inlet guide 1 mounted, air inlet guide 2 and restrictor slide are supplied separately.

Table 7-5d

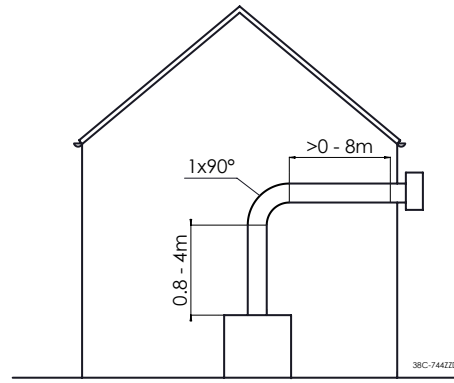

| Setting | Apply |
|------------------|-------|
| Air inlet guide | x |
| Restrictor slide | x |

- Only use a 200/130 mm concentric system, including wall terminal.
 - Factory setting: Air inlet guide 1 mounted, air inlet guide 2 and restrictor slide are supplied separately.
 - There are many more possibilities in combination with the DRU PowerVent system (DRU PV-I 100/60) (see PowerVent installation guide).

Table 7-5e

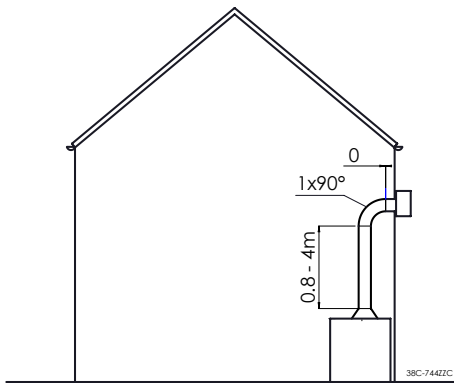

| Setting | Apply |
|------------------|-------|
| Air inlet guide | x |
| Restrictor slide | x |

-Install a connecting piece reducing the concentric system to 150/100 mm directly onto the appliance.
 - After this point, use only a 150/100 mm concentric system (no horizontal length permitted).
 - Install the concentric system using stainless steel or aluminium/galvanised flue piping throughout.
 - Factory setting: Air inlet guide 1 mounted, air inlet guide 2 and restrictor slide are supplied separately.

7.3.4 Connection to an existing chimney

The appliance can be connected to an existing chimney (C91). A 100 mm diameter flexible SS pipe is placed in the chimney for discharging flue gases. The surrounding space is used as combustion air supply. Use the DRU spacer here. Place this spacer every three metres.

In case of an appliance connection of $\varnothing 200/130$ mm, 0.8 metres of concentric system must first be connected vertically. Reduce the concentric system after the first 0.8 metres to a diameter of 150/100 mm. The concentric system of 150/100 can be connected to an existing chimney.

The following requirements apply when connecting to an existing chimney:

- Only allowed when used in combination with the special DRU chimney kit.
- The internal dimensions should be at least 150 x 150 mm.
- The vertical length has a maximum of 12 metres.
- The total horizontal pipe length may have a maximum length (see table 7-3).
- The existing chimney has to be clean.
- The existing chimney has to be tight.

For adjusting the appliance, the same conditions/instructions apply as for the concentric system described above.

7.4 Placing the chimney breast

For a good heat discharge and operation of the appliance, there should be sufficient space around the appliance. The chimney breast should be ventilated sufficiently by means of ventilation holes (incoming and outgoing).



- When an appliance is built in the floor, please take into account the minimum distances from the floor/ground in front of the appliance (see fig. 7-12).
- Use non combustible and heat-resistant material for the chimney breast, including the top of the chimney breast, the material inside the chimney breast and the back wall of the chimney breast.
The appliance is not a support structure. Make sure the appliance does not have to bear the weight of the chimney breast for example.
- The passage of the ventilation holes (outgoing) is stated in table 4-1. If it is not possible to use a control hatch in the chimney breast, an air supply of at least 80 cm² must be placed as low as possible, but not above the burner surface. If a control hatch can be used, the control hatch will suffice as air supply (see section 7.5).

- ⚠ When placing the chimney breast, you should take the following into account:
- The minimum dimensions of the chimney breast surround (see fig. 7-13).
 - The location of the control hatch: this must be placed as low as possible.
 - The distance of the control hatch up to the side of the appliance (see fig. 7-14).
 - The dimensions of the control hatch (see section 7.5).
 - The location of the ventilation holes (V-out).
 - A minimum 30 cm distance between the top of the ventilation hole (outgoing) and the ceiling of the house.
 - The dimensions of the glass pane, so that it can be placed/removed after placing the chimney breast.
 - The protection of the gas control and the pipes against cement and plaster.
 - Placement of decorative strips, frames and such like; if possible, install these after the carrying out any structural work. If this is not possible, protect them during this work. Avoid the use of painter's tape. If this is not possible: use good quality painter's tape and remove this tape immediately after plastering or painting work (prolonged application of painter's tape may cause damage).

- ⚠ You should preferably apply the ventilation holes (outgoing) on both sides of the chimney breast. Use the DRU ventilation elements.

Check the following items, before the chimney breast is fully closed:

- Is the discharge / concentric system placed correctly?
- Have the channels, fastening brackets and possible clip bindings, that become inaccessible later, been secured with self-tapping screws?
- Has no plastering work been performed on or across the edges of the construction frame? This due to the fact that:
 - the heat of the appliance could cause cracks;
 - It will no longer be possible to remove/place the glass pane.
- When using stone-like materials and or plaster finishing, allow the chimney breast to dry for at least six weeks prior to taking the appliance into operation in order to prevent cracks.

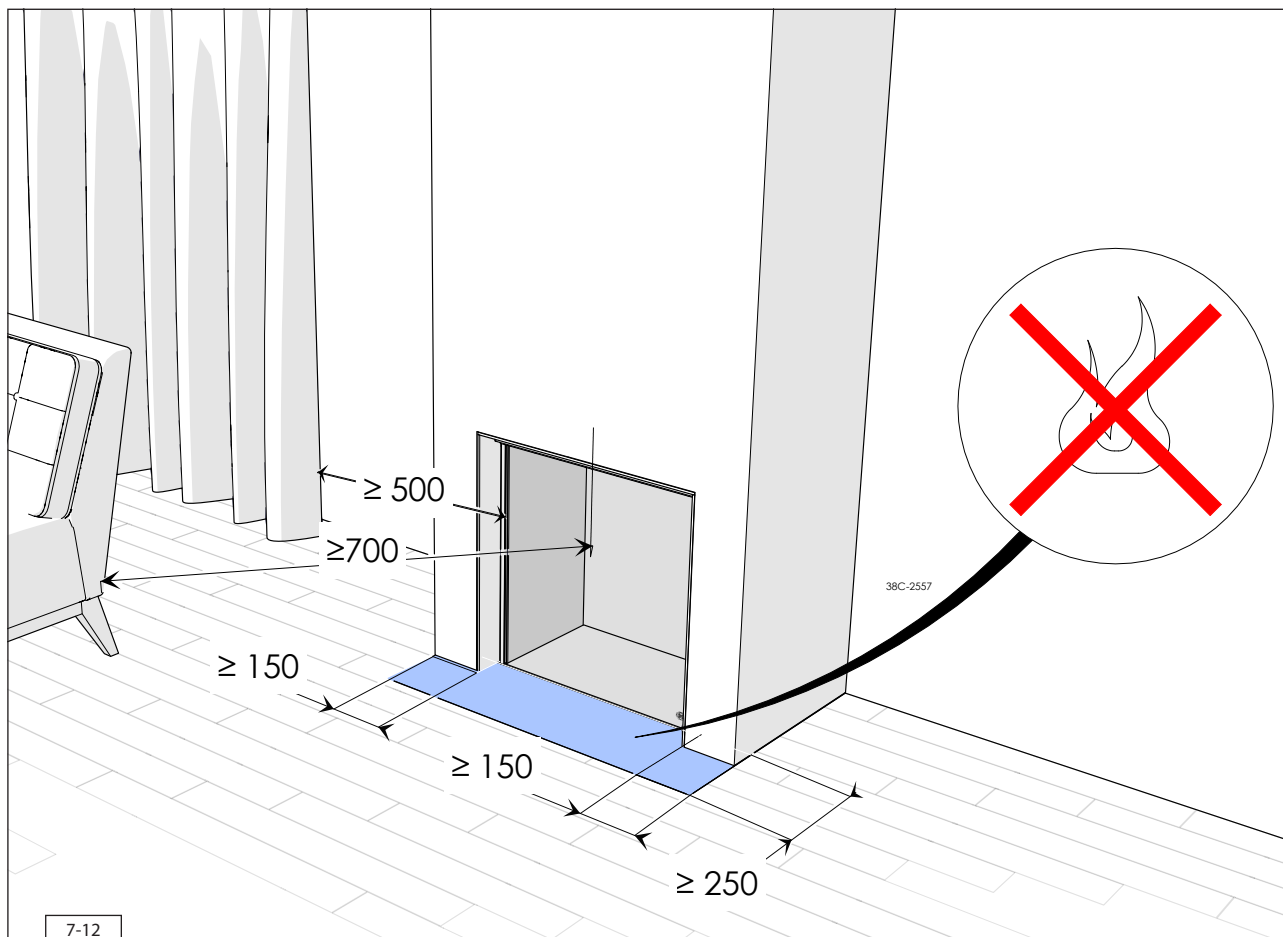

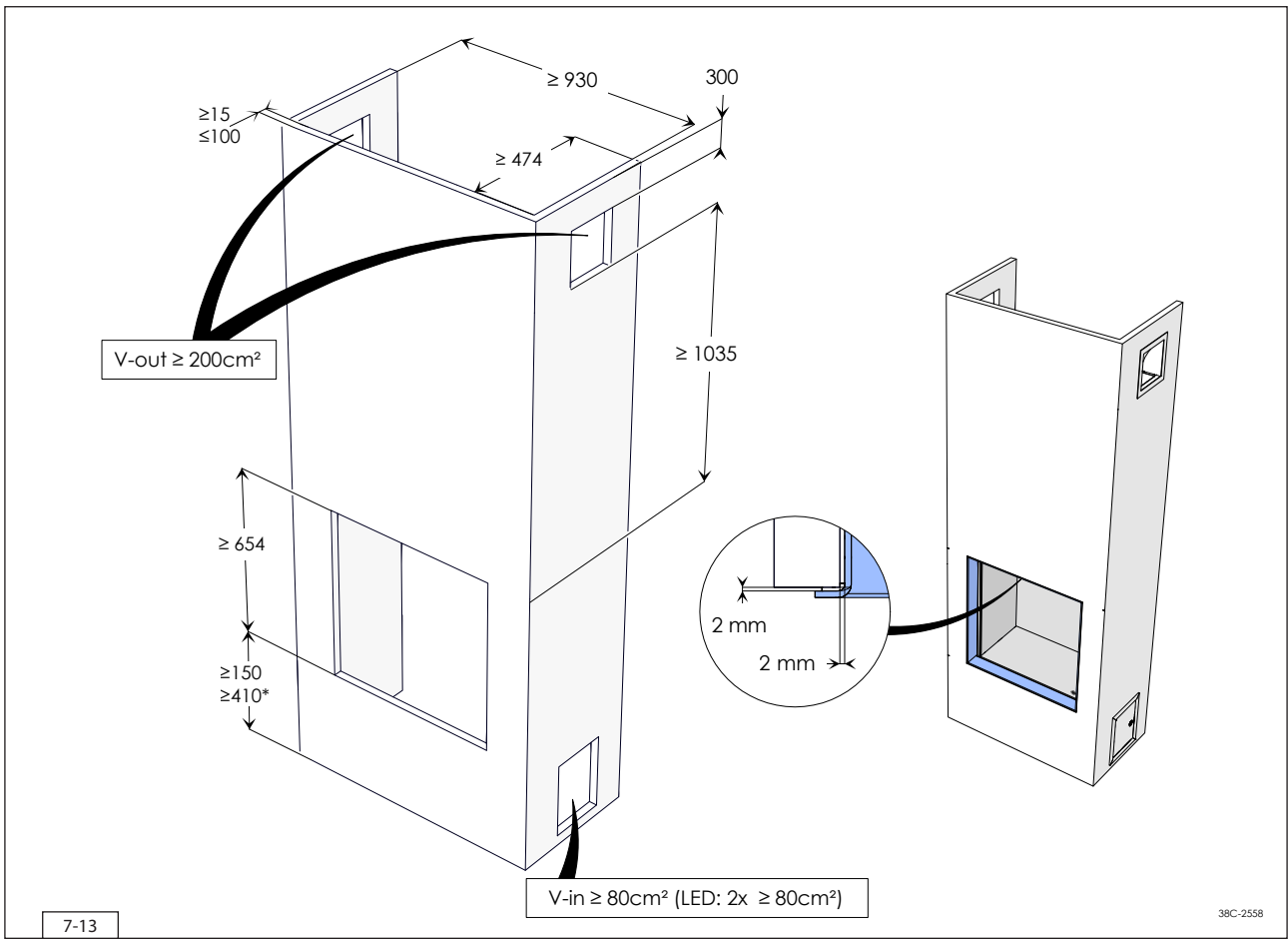

* Taking into account the control hatch, placed as indicated.

- ⚠ With LED appliances, an additional ventilation hole (V-in) must be installed. A ventilation inlet of 80 cm² must be present on both sides to ensure sufficient cooling. No additional incoming ventilation hole is required if the appliance is placed at least 30 cm above the floor, in which case a single incoming ventilation hole of 80cm² is sufficient.

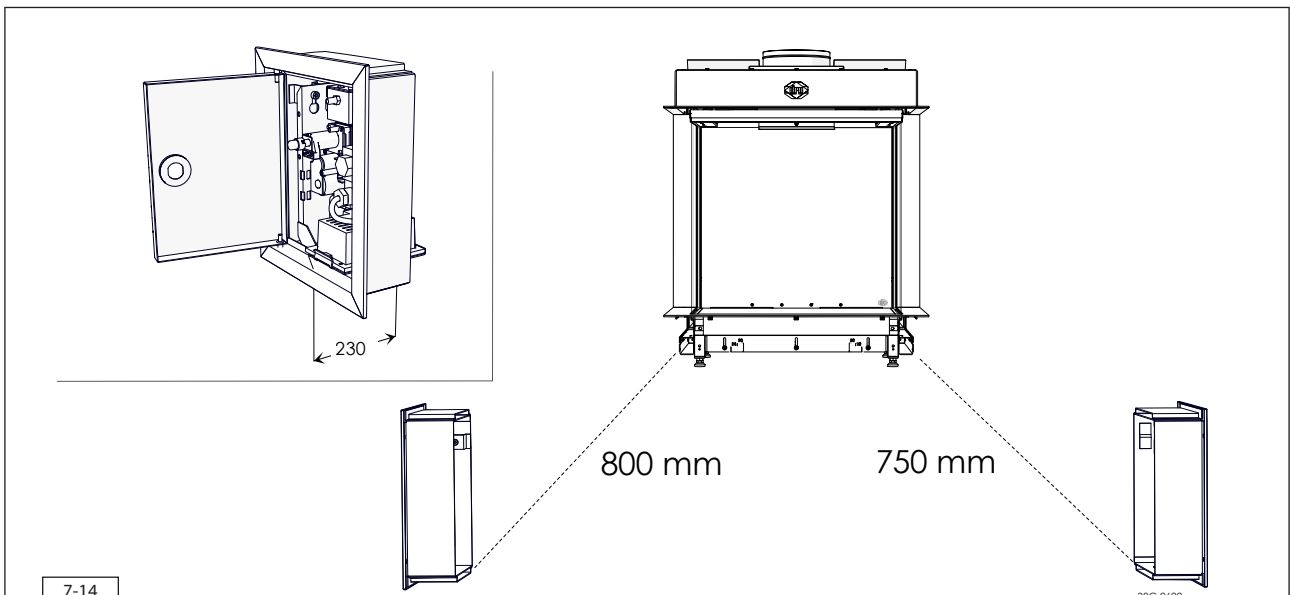

7.5 Placing the control hatch

A number of components are placed in the control hatch, such as data plate, gas control and, if applicable, components belonging to the DRU Powervent System*.

The control hatch was designed in such a way, that all components as well as adjustment, measurement and regulating provisions are within optimum reach and the components work optimally. A control hatch placed and furnished on the side of the chimney breast ensures an optimum transmission and reception strength of the remote control and receiver. The control hatch also ensures sufficient aeration of the chimney breast. For that reason, the use of a control hatch is not without significance. Not using a control hatch could void the warranty.

- ⚠ - The bottom of the control hatch may not be placed higher in the appliance than the burner surface.
 - Place the control hatch and bracket with gas control only indoors, on a dry spot!
- Place the control hatch as follows (see fig. 7-15):
- Make an opening in the chimney breast as described in the manual for the control hatch (1).
 - 💡 The opening in the chimney breast may be made horizontal and vertical.
 - Place the inner frame. For this, first remove the outer frame with door (2).
 - ⚠ The inner frame should be placed in the correct way. Two positions are possible. Placing the inner frame with a rotation of 180° is not allowed.
 - 💡 When the chimney breast is made of bricks, the inner frame can be built with bricks at the same time. In case of a different material, the inner frame can be glued or fastened with four countersunk screws.
 - Fix the outer frame with door (3) to the inner frame using two Allen screws.
 - 💡 The outer frame can be placed in such a way that the door turns to the left or right.
 - Attach the bracket with gas control to the inner frame. Proceed as follows:
 - Unwind the cables. This will, amongst other things, prevent a poor operation of the ignition (4).
 - Unwind the flexible gas pipe(s).
 - Mount the bracket with gas control to the inner frame. The slotted hole falls in Allen screw; the hole at the bottom falls over the head of Allen screw.
 - Fix the bracket with Allen screw.
 - ⚠ - Avoid kinks in the pipes (4).
 - Do not lay the cables of the ionisation pin and spark electrode along metal parts, wiring and other components.
 - Connect the gas pipe with gas tap (6) (also see section 6.3).
 - Bleed the gas pipe (7).
 - 💡 If the gas tap is closed, the bracket with gas control can be easily removed by loosening the clamp coupling under the gas control and loosening the Allen screw (C) by a few turns. The bracket with the gas control can now be lifted and removed towards the front out of the control hatch.
 - Place the data plate in its intended clamp (8).
 - Connect the 230V mains voltage with protective earth using the correct type of plug. The other side of the power cable can be easily connected to the universal 230V plug in the control hatch. Use this universal 230V plug to disconnect the appliance from the power supply, if necessary.
 - ⚠ If the 230V power cable is damaged, replace it by a similar power cable or a power cable that is available from your dealer.
 - ⚠ Always close the control hatch with the lock (10), because of the electricity behind the door (230V). The lock is operated by means of a fitting flat object.

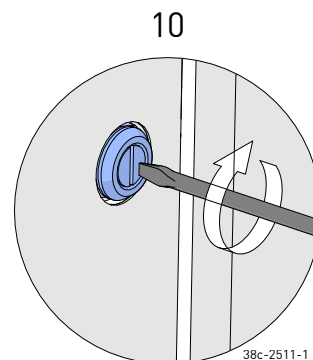
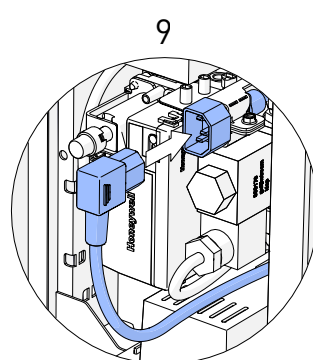
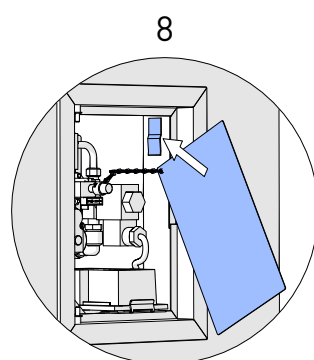
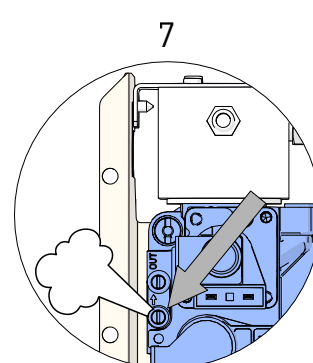
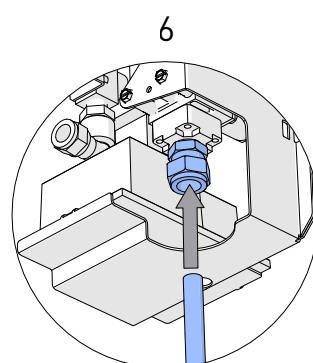
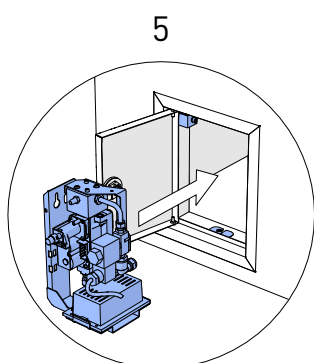
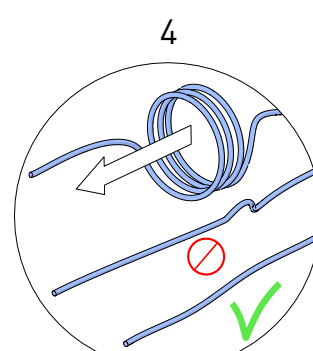
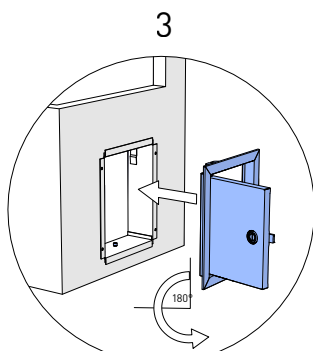
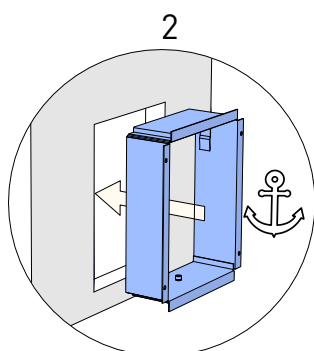
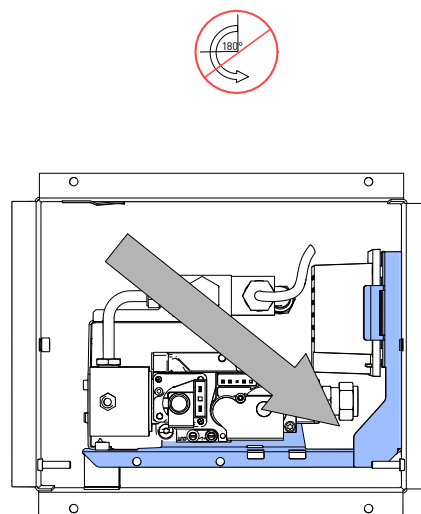
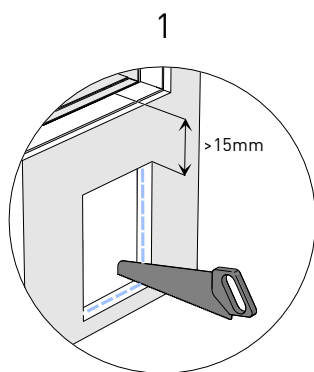
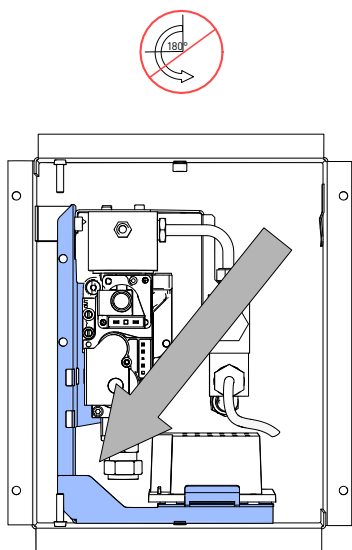

38c-2511-1

8. Appliance

8.1 Glass panes

The glass pane of this appliance is easy to open to allow cleaning of the inside of the pane. Before installing the wood set, adjusting the appliance or maintenance, the glass pane must be removed.

8.1.1 Opening the glass pane

Proceed as follows to open the glass pane (see fig. 8-1).

- Press the locking hooks at the top left and right upwards to unlock the glass pane. The locking hooks are lifted by pressing on the cams situated in the profile above the glass pane (1).
- Keep the cams depressed and pull the glass pane forward on the profile (2).
- ⚠ Avoid fingerprints, as they will burn into the glass.
- Tilt the glass pane until it is in the open position. The catch brackets ensure that the glass pane remains in the open position.
- ⚠ Only open the glass pane if the appliance is turned off and is at room temperature.

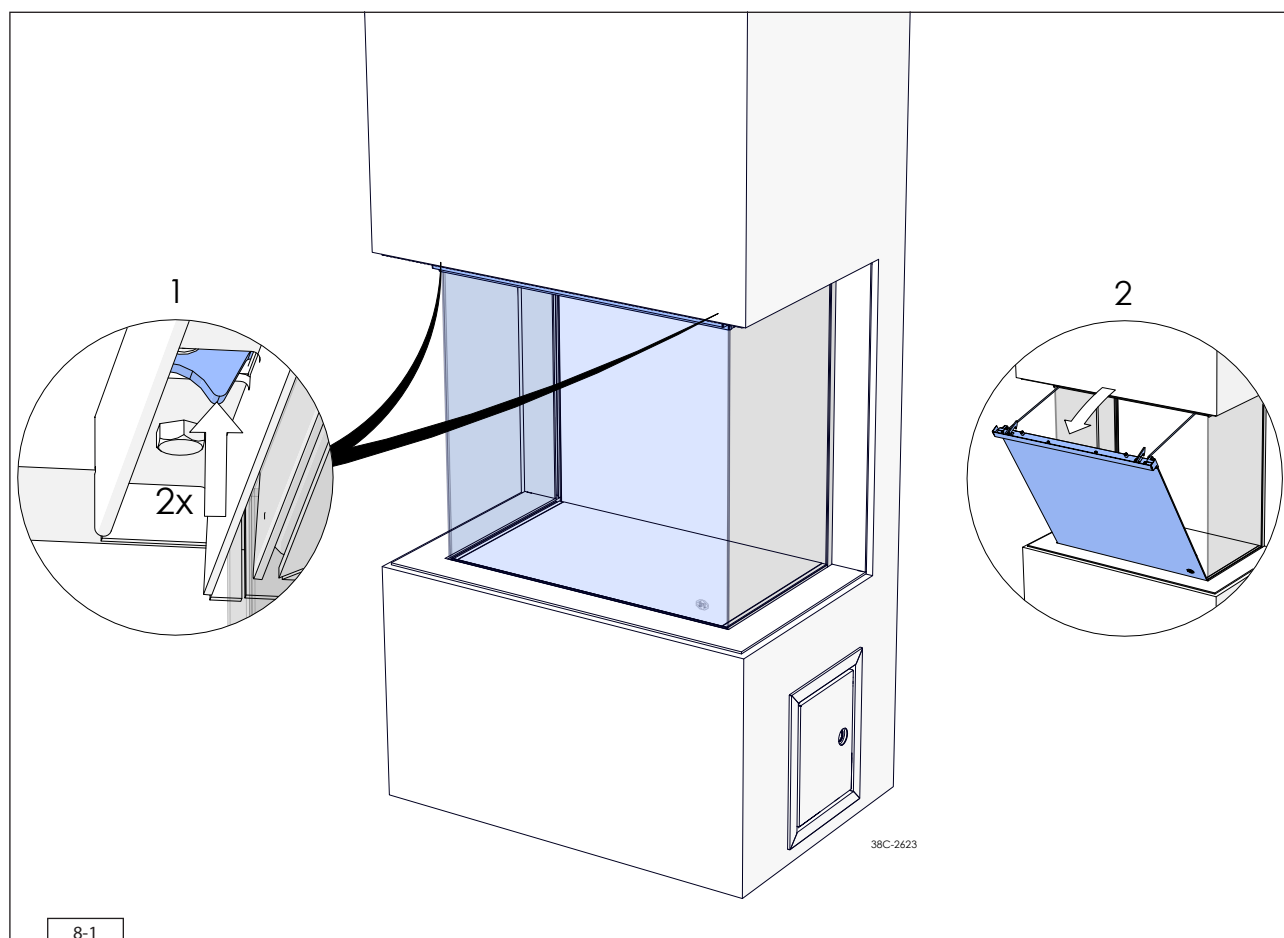

8.1.2 Closing the glass pane

Close the glass pane once it has been cleaned. Proceed as follows to close the glass pane (see fig. 8-2).

- Close the glass pane by pushing the profile at the top of the glass pane towards the appliance (1).
- The glass pane will close automatically.
- ⚠ Avoid/remove fingerprints on the glass pane, as they will burn into the glass.
- ⚠ Ensure that the locking hooks are pushed back into place correctly.

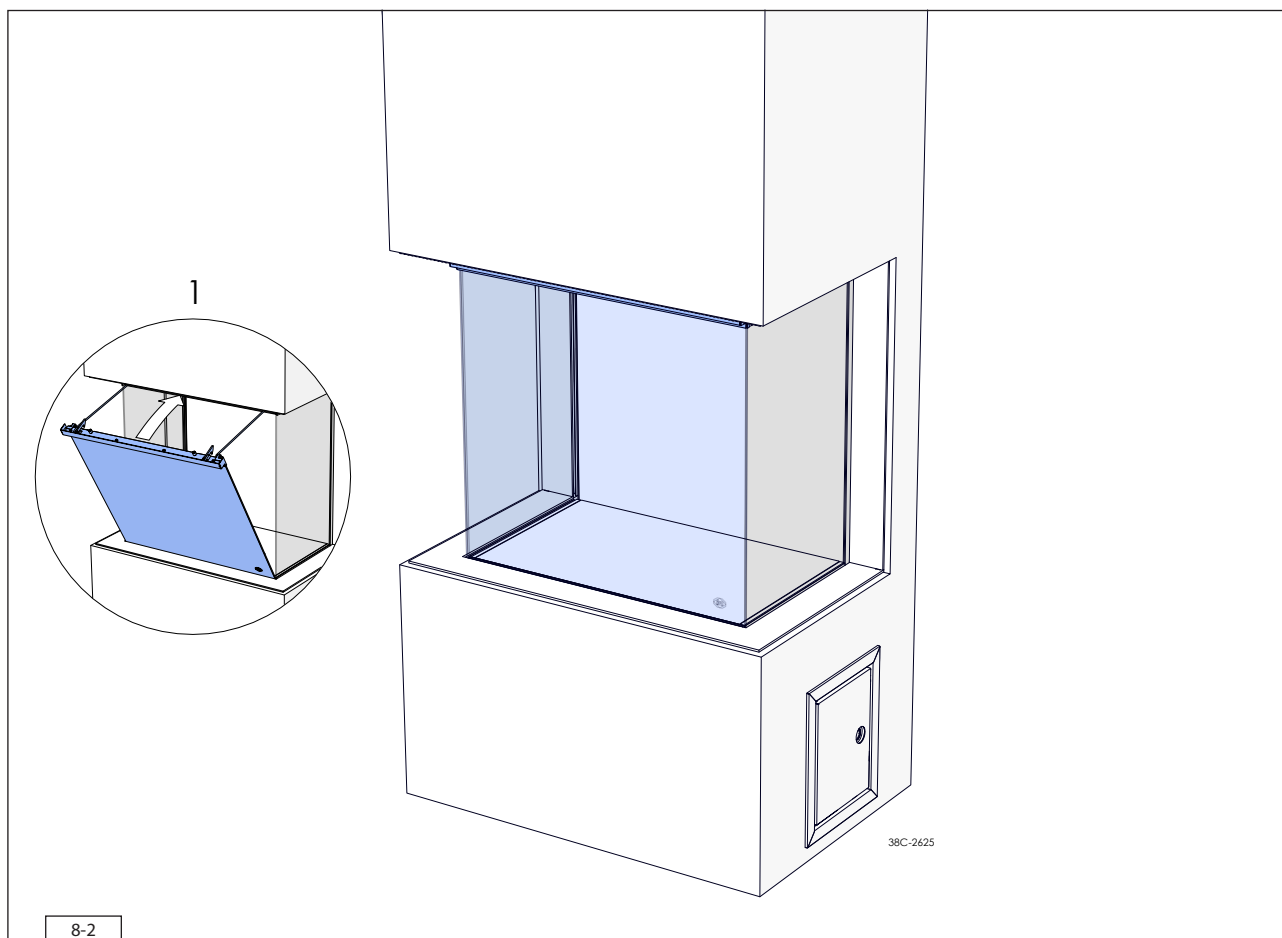

8.1.3 Removing glass pane

Proceed as follows to remove the glass pane (see fig. 8-3):

- Open the glass pane (see section 8.1.1).
 - Swivel the catch brackets out of the holder by pulling them inwards (1).
 - Slide the catch brackets inwards so that they cannot obstruct the work, but ensure that they can be reached later.
 - Grasp the glass pane on both sides at the bottom and hold the glass pane at the angle of the open position.
 - Pull the glass pane upwards so that it slides out of the slot and remove the glass pane (2).
- ⚠ - Avoid damage to the glass pane.
 - Avoid fingerprints on the glass pane by wearing suitable gloves.
 - Store the glass pane in a safe place.

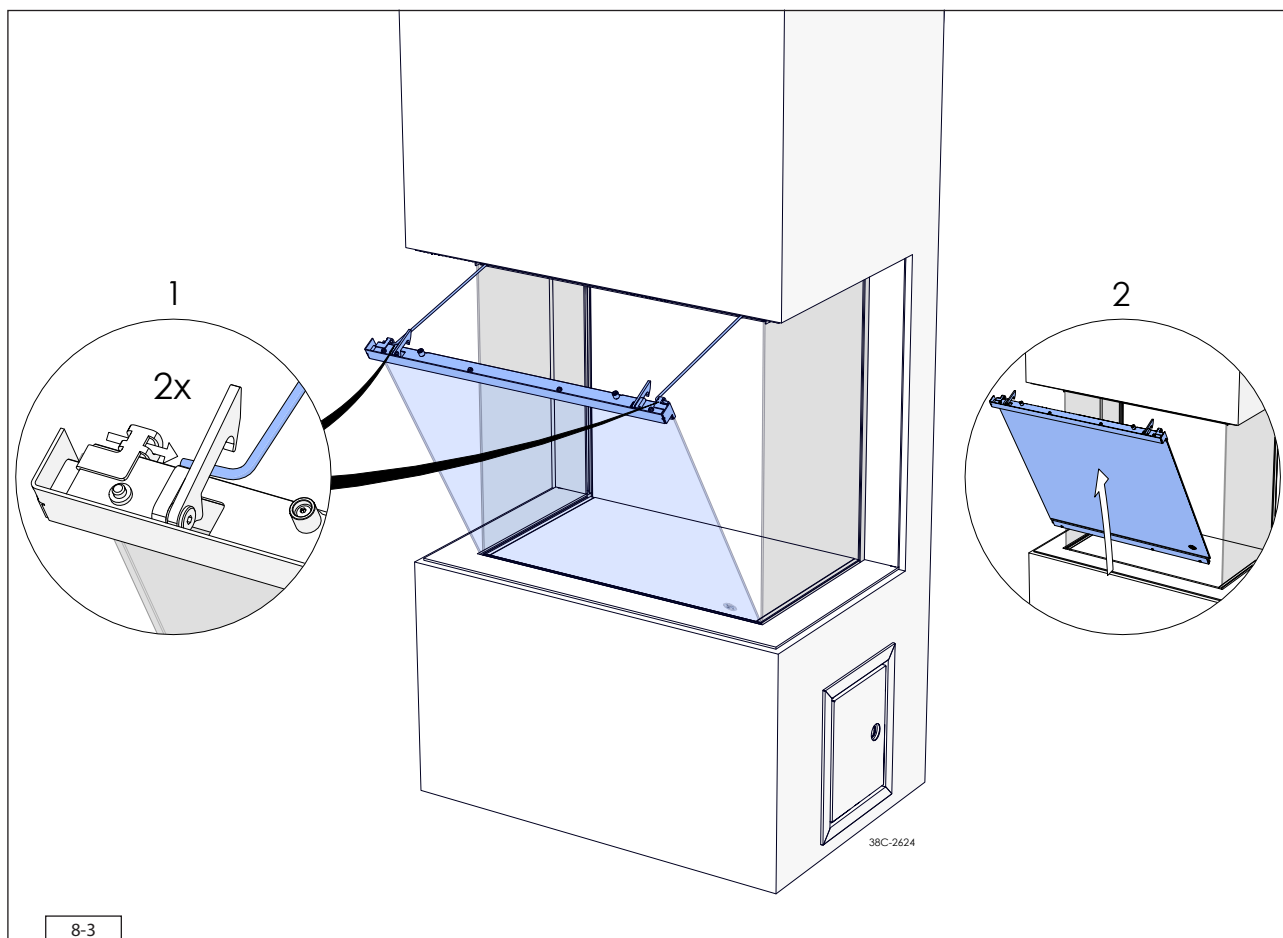

8.1.4 Reinstalling glass pane

Reinstall the glass pane once the appliance has been correctly adjusted, the wood set has been installed, the glass pane is clean or following maintenance. Proceed as follows to reinstall the glass pane (see fig. 8-4).

- Grasp the glass pane on both sides at the bottom and hold the pane at the angle of the open position (1).
 - Push the profile at the base of the glass pane into the vertical position, and hold it in position (2).
 - Place the glass pane into the correct position. This is dead centre in front of the appliance, with the profile at the base of the glass pane above the slot.
 - Allow the glass pane to drop into the slot and press it firmly into position.
 - Place the catch brackets back in the holders (3).
 - Close the glass pane (see section 8.1.2).
- ⚠ - Avoid damage to the glass pane and appliance.
 - Avoid fingerprints on the glass pane by wearing suitable gloves.
- ⚠ - Ensure that the glass pane is properly centred.
 - Make sure the groove in which the glass pane is placed is free from dirt prior to installing the glass pane.

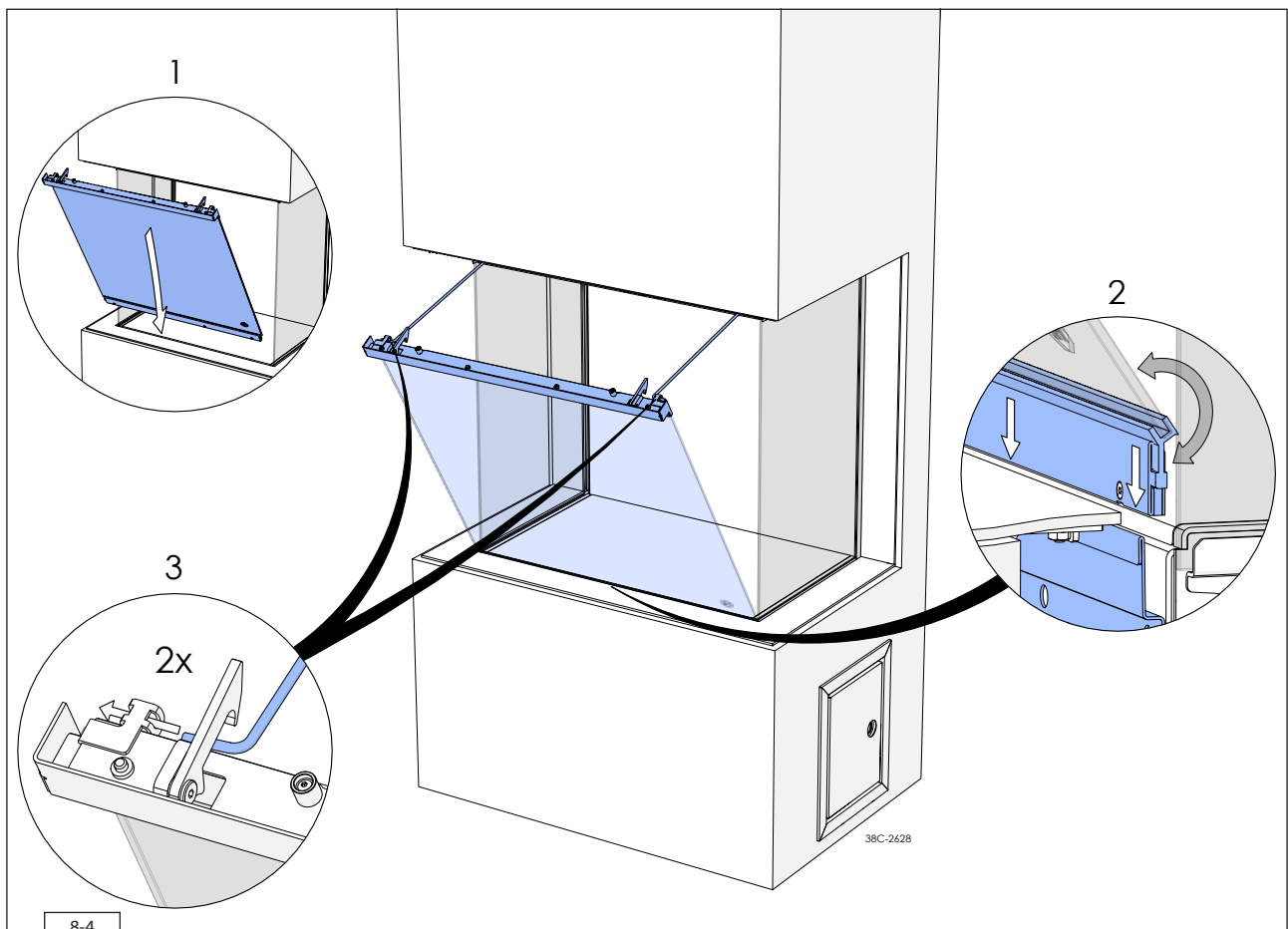

8.2 Adjusting the appliance

The appliance must be set up in such a way that it works correctly in combination with the smoke exhaust system. For this purpose, a restrictor slide may be installed, or the air inlet guide removed or replaced. The conditions for use with wall and roof terminal are indicated in tables 7-3 to 7-5.

8.2.1 Restrictor slide

The restrictor slide is supplied separately. It is installed as follows (see fig. 8-5):

- Remove the glass pane from the appliance (see section 8.1.3).
 - Remove the flue gas distribution plate (1).
 - Install the restrictor slide (2). The restrictor slide falls over part of the flue gas pipe hole, do not yet tighten the self-tapping screws.
- ⚠ When fixing, the arrow on the restrictor slide must point backwards.
- Adjust the position of the restrictor slide by following situations B, C and D (see table 7-4). The letter of the position on the restrictor slide corresponds with the letter of the situation.
 - Make sure that the point of the triangle, of the correct position, and the centre of the self-tapping screw are exactly aligned (3).
 - Tighten the two self-tapping screws.
 - Reinstall the flue gas distribution plate (4).
 - Reinstall the glass pane once the correct air inlet guide and wood set have been installed correctly (see section 8.3).

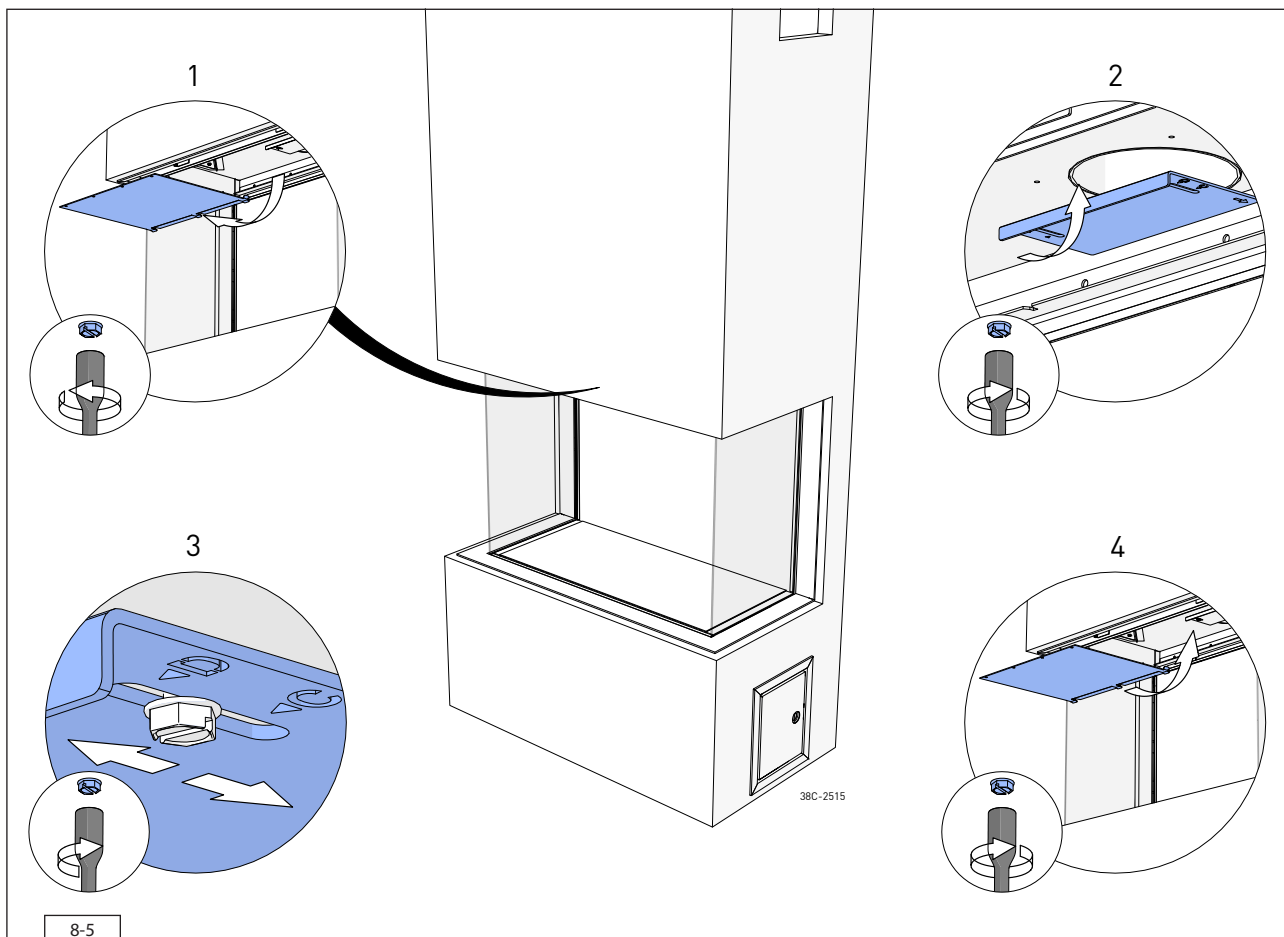

8.2.2 Air inlet guide

Air inlet guide 1 is fitted and air inlet guide 2 is supplied separately. To replace or remove air inlet guide 1, proceed as follows (see fig. 8-6):

- Remove the glass pane from the appliance (see section 8.1.3).
- Unscrew the self-tapping screws from the rear vermiculite plate (1) and remove them.
- Remove air inlet guide 1 at the bottom rear of the appliance (2).
- Install air inlet guide 2 and fasten it with the self-tapping screws (3). If no air inlet guide is used, the self-tapping screws must be placed back in the appliance.
- Screw the rear vermiculite plate back in place (4).
- Reinstall the glass pane once the wood set has been installed correctly (see section 8.3).

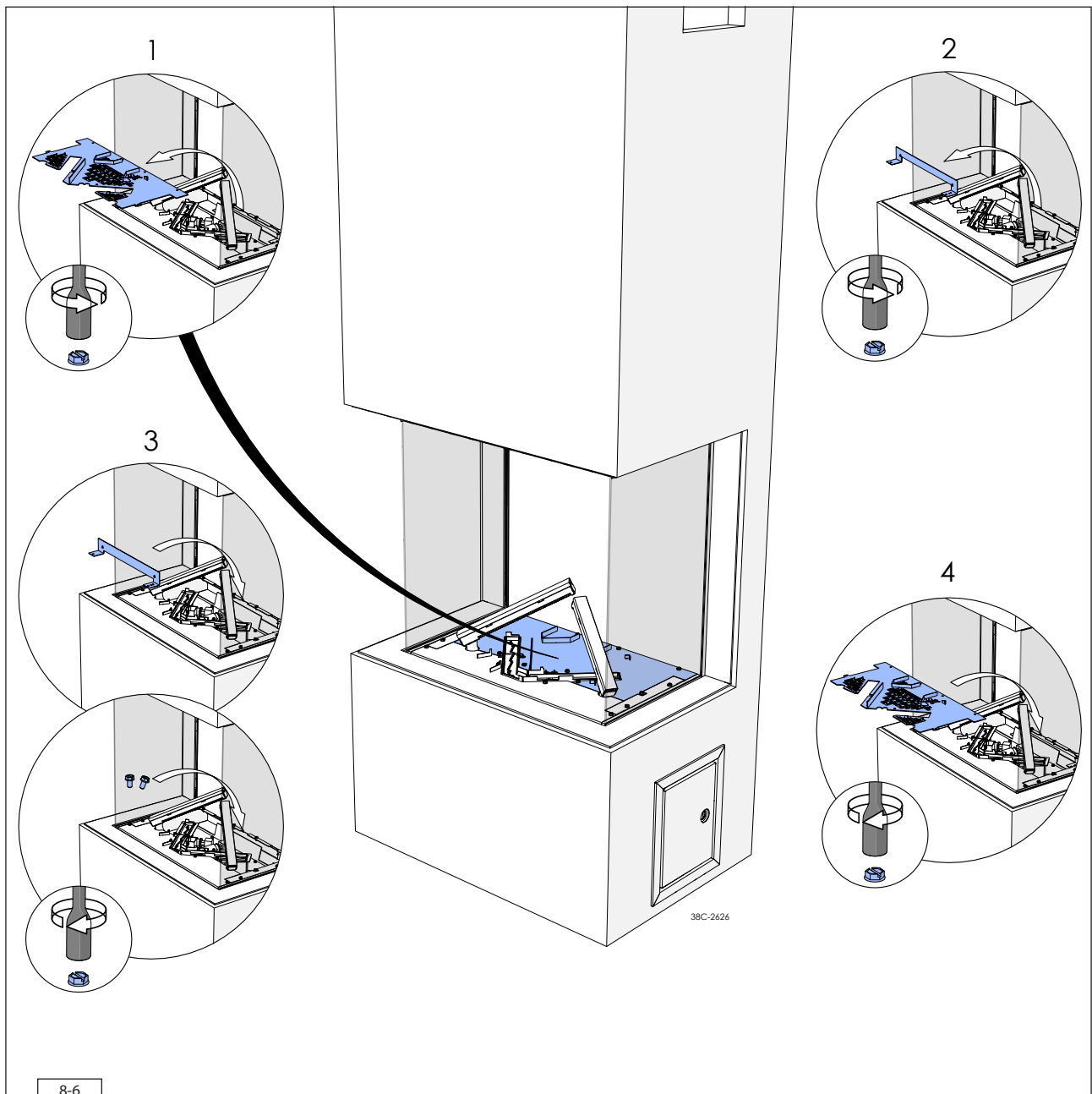

8.3 Wood set

The appliance is supplied with a wood set.

- ⚠ The figures do not always show the correct colours.
- ⚠ Observe the instructions below to prevent unsafe situations:
 - Only ever use the supplied wood set.
 - Place the wood set exactly as described.
 - Make sure the ionization and spark electrodes and the surrounding space remain free (see fig. 8-7 and 8-8).
 - Make sure there is no vermiculite dust on the burner.
- ⚠ Place the logs exactly as described, otherwise:
 - The main burner will not ignite properly; which could result in unsafe situations.
 - The appliance will become filthy more quickly, as a result of soot.
 - The flame picture will be affected.



8.3.1 Installing the wood set

The wood set consists of a number of logs (see fig. 8-9), vermiculite (see fig. 8-10), chips (see fig. 8-11), glow material (see fig. 8-12) and ash (see fig. 8-13).

For LED appliances, an extra set of glow rocks is supplied (see fig. 8-14).

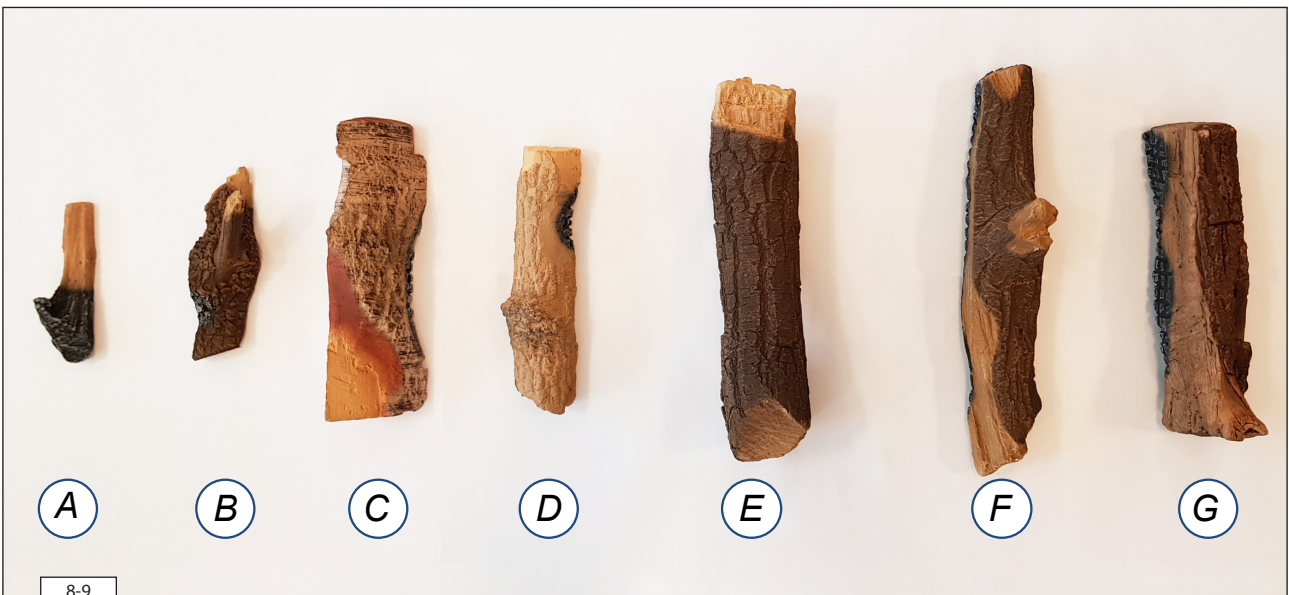

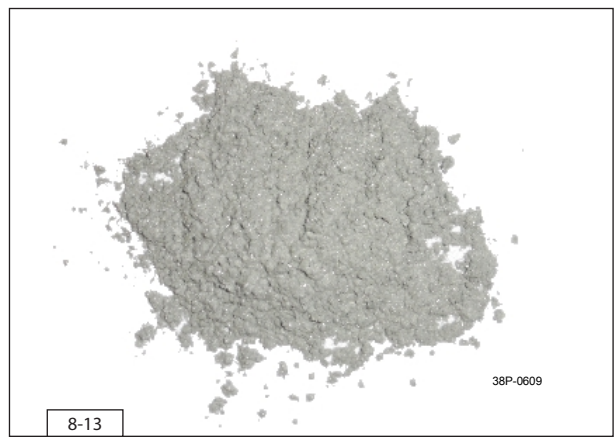
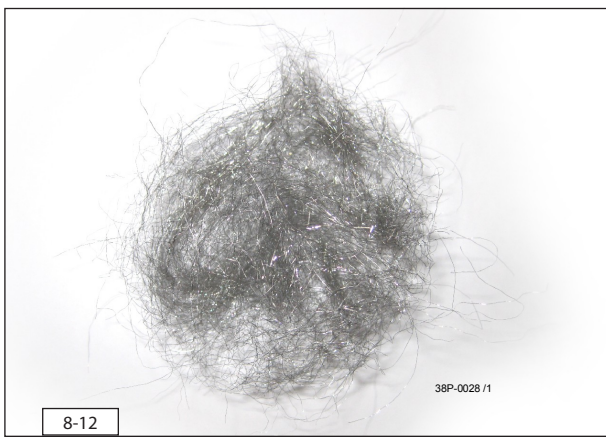
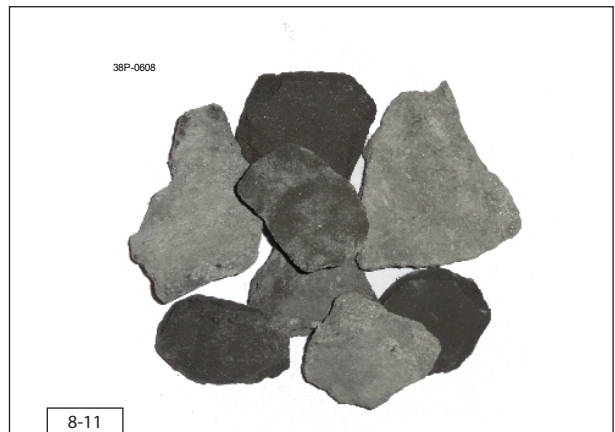

- Fill the V-shaped burner with vermiculite; evenly spread the vermiculite (see fig. 8-16). The flame picture can be altered by moving the vermiculite.
- ⚠ - The vermiculite may not get higher than the edge of the burner.
- The burner deck has to remain covered with vermiculite in order to prevent reduction of the burner's life span.
- If desired, glow material may be installed. Pull the glow material into loose tufts and spread it over the sections on the V-shaped burner marked in green (see fig. 8-16).
- ⚠ - Keep the areas around the ionization and ignition free of glow material.
- The glow material may affect the colour of the flame picture.

- LED appliances have a different type of base covering to appliances without LEDs.
- ⚠ - The vermiculite plates are provided with square holes, which ensure air supply. Do not place more than one layer of base covering over these holes.
 - Ensure that the base covering does not enter the slot for the glass pane.
- For appliances **without LEDs**, use all chips in the wood set.
 - Fill the vermiculite plates with chips, spread the chips evenly, keep the sections marked in red free of chips (see fig. 8-17).
 - For appliances **with LEDs**, use the glow rocks, coals and a portion of the chips as indicated in the woodset.
 - 💡 First place the glow rocks and then the coals. Switch on the glow lighting while placing, so that the stray light can be seen directly and covered with the rocks and coals.
 - Spread the glow rocks over the grid pattern and square holes in the vermiculite plate, keep the sections marked in red free (see fig. 8-18).
 - Spread the chips over the remaining sections, keep the sections marked in red free.
 - 💡 Summerlight works best in combination with the 'black smooth' decorative plates. Other decorative plates filter the effect, making it invisible or difficult to see.
 - Identify logs A to G (see fig. 8-9).
 - 💡 Use the burn marks on the logs for identification.
 - Place log A on the positioning lugs (see fig. 8-17).
 - Place log B parallel to the burner on the front two positioning lugs. The rear side must be parallel with the rear positioning lug.
 - Place log C with the slot above the positioning bracket and allow the groove at the rear to slide over the positioning lug.
 - Place log D to the rear of log C (see fig. 8-12).
 - Place log E with the rear side in the positioning lug and place the front side in the groove of log E. There must be a gap of at least 1 cm between the right burner and log E.
 - Place log F above the left burner. The log must fully rest on the burner and must not be supported by the base covering (see fig. 8-21).
 - Place log G above the right burner. The log must fully rest on the burner and must not be supported by the base covering.
 - LED appliances have a different type of base covering (see fig. 8-22).
 - Spread the ash, if desired, over the base covering, ensure that it does not cover the burners.
 - Reinstall the glass pane (see section 8.3).



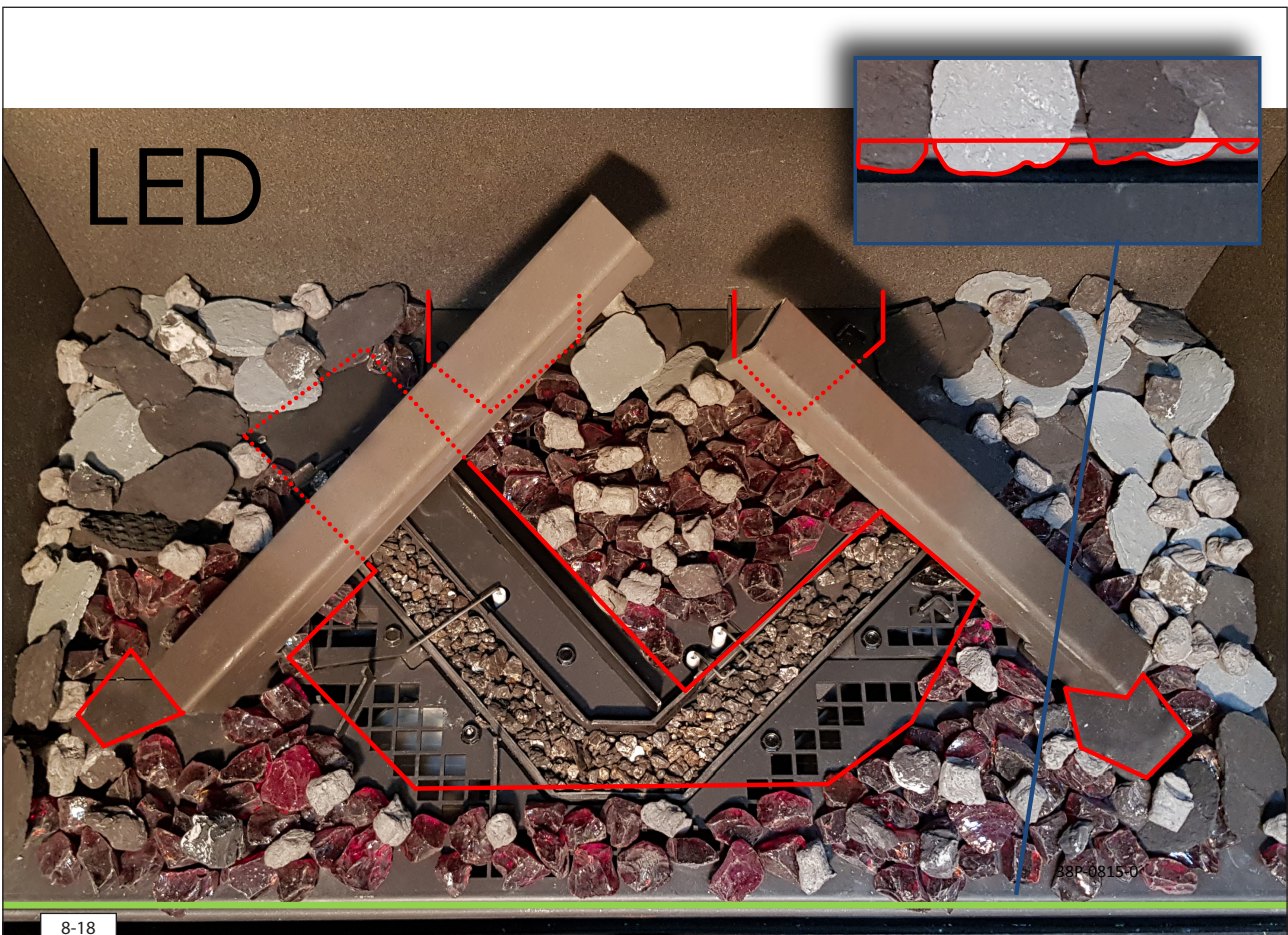

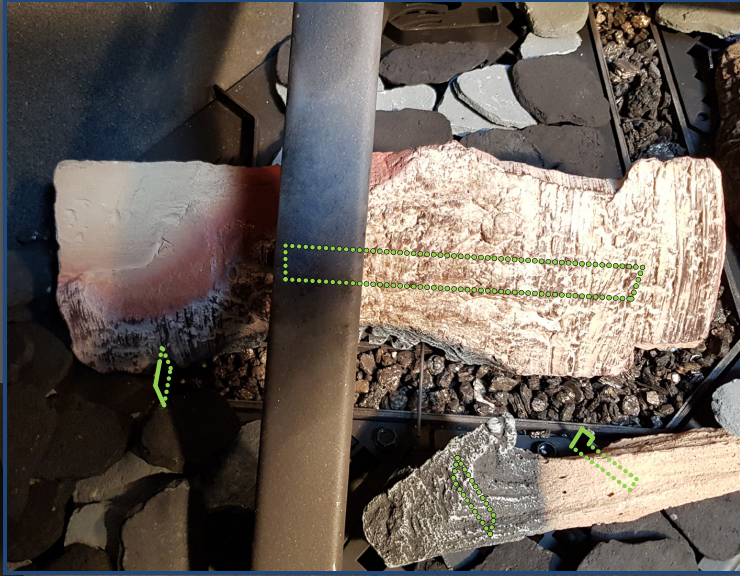

38P-0816-0

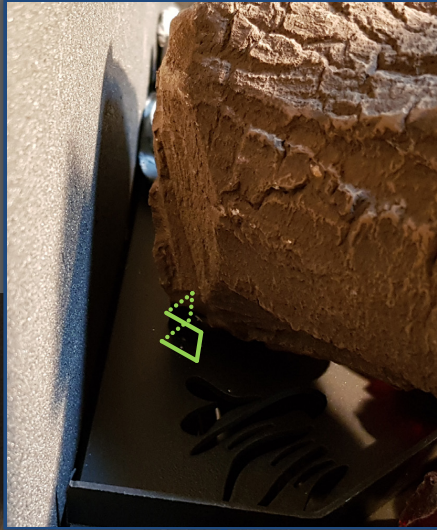

38P-0817-0



9. Control/operation

The appliance is supplied with a wireless black remote control for the user (see fig. 9-1 (B)). As an option, an orange remote control can be supplied for the installer (see fig. 9-1 (O)). Flame height, ignition and switching off are controlled by the black remote control controlling the receiver. Some appliances can also be controlled in an alternative way. These options are described further down in this chapter. The user manual describes the operation of the appliance, including the operation of the remote control and alternative methods of operation.

- ⚠ - Do not ignite the appliance until it is fully installed when it comes to the gas connections, discharge system and electrical components.
- Chapter 6 of the manual supplied applies to an appliance equipped with the CM system.

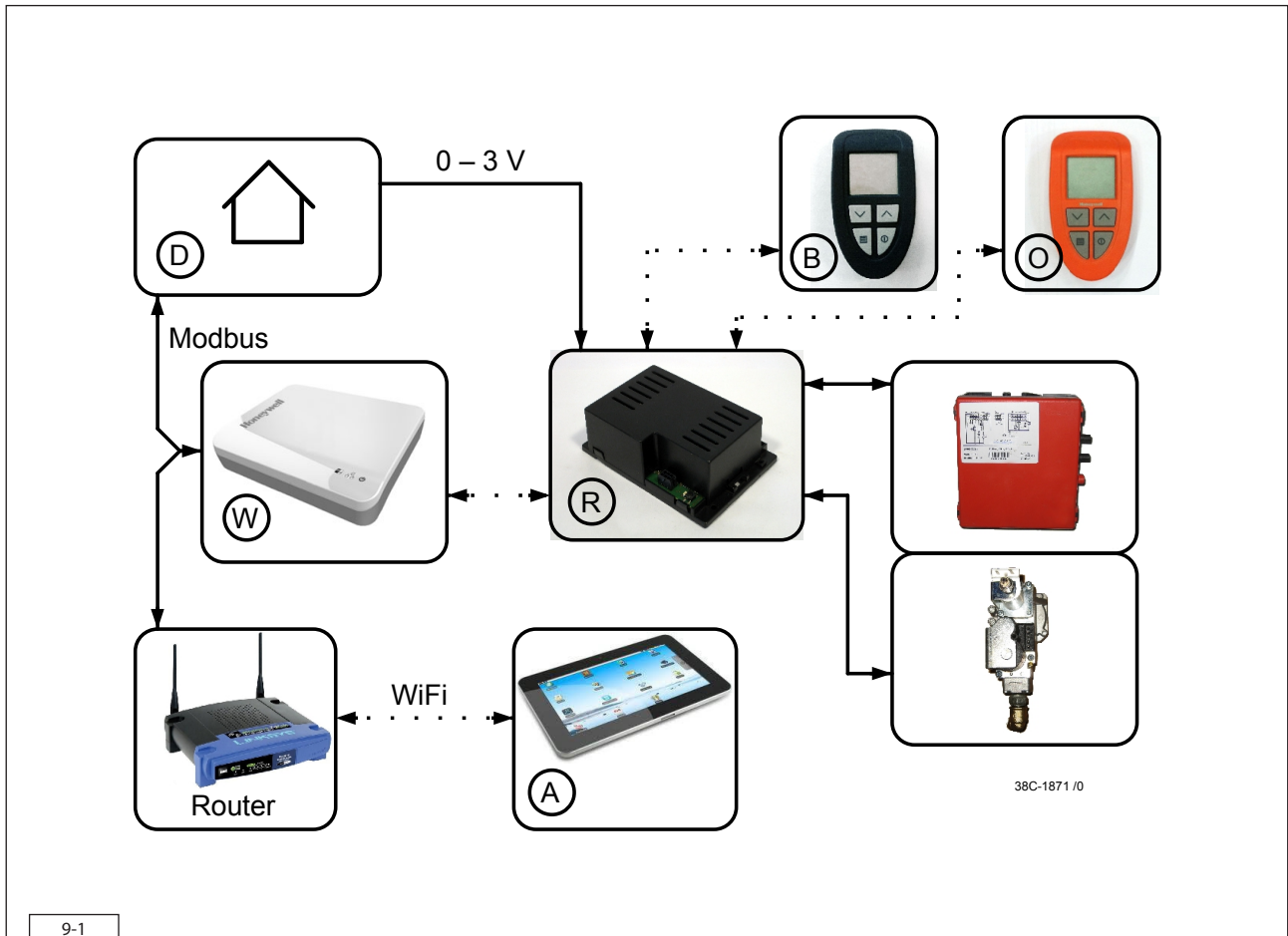

9-1

9.1 Principle of ignition cycle

Below you will find a brief description of how this appliance is ignited. The appliance is off and will be switched on by means of the remote control. The receiver in the appliance will get a signal from the remote control to start the ignition process. This signal is passed on to the burner device, after which, if applicable, the relay for the Powervent System[®] is switched. After an 8 second interval, the ignition on the spark electrodes will start. If no Powervent System[®] is connected, only the relay will switch and the appliance will ignite immediately. The main burner will be ignited at about 50% of its capacity. This will prevent a larger amount of gas in the combustion chamber, if no ignition takes place. When the gas ignites, ionization will have to be detected. In order to make sure the flame has passed over, this will take place at the other side of the burner. When ionization is detected, the gas control will modulate to 100%. In the case of a switchable second burner, the second valve is switched after this (you will be able to hear a 'click') in order to ignite the second burner. After ignition of the second burner, the appliance will always go to full output (full capacity). This will guarantee that the second burner will actually ignite. The second burner can be switched on and off manually, by means of the remote control. In case of switching on manually, the appliance will first return to full load.



The control unit of the appliance meets strict safety demands. It is possible that the burning appliance switches off automatically and then switches back on again. This is not a failure, but a check. The moment the appliance's control unit is connected to mains voltage, the control unit will perform this check every 24 hours. If the appliance is burning at that time, the appliance will extinguish and then start again immediately. This can be prevented by removing the plug from the socket and immediately inserting it again at a time when the appliance is never or hardly ever burning.

9.2 Connecting the switch contact

(if applicable)

It is possible to operate one or more lamps (in case of several lamps, a maximum of 0,5A/250VAC/30VDC) via the remote control of the appliance. You could think of the lamps of Dru's lux elements. For this, you can use switch contact B on the receiver (see fig. 9-2). If the appliance is provided with LED lighting, switch contact 'B' is cancelled. The switch contact is not polar sensitive.

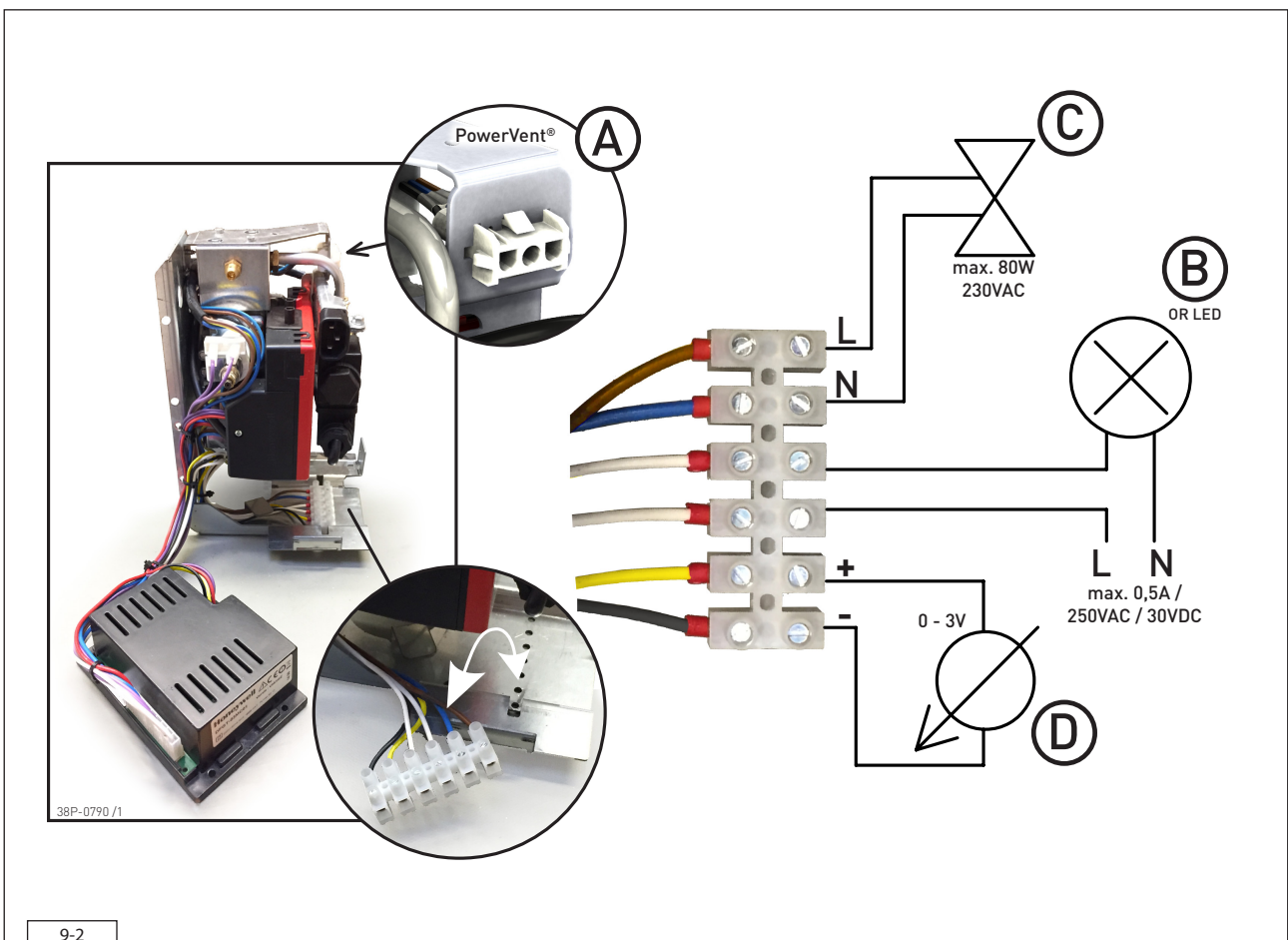

9.3 Connection extra power supply (max. 80W, 230VAC)

(if applicable)

This connection is ideal for possible lighting or a ventilation system in the chimney breast and can be operated by means of the remote control (see Fig. 9-2 (C)). The power supply of this connection is identical to the mains voltage and it can be subjected to a maximum load of 80 Watts.

9.4 Remote controls

9.4.1 Black remote control for the user

Proceed as follows to make the black remote control ready for use:

- Place the two penlite batteries (AA) in the battery holder of the remote control.
- Make sure the voltage of the appliance is not switched off for longer than 5 minutes.
- If the remote control is not on 'BND', you must proceed as follows:
- Press the 'menu' button (button with square symbol) on the remote control for at least 10 seconds and then press a few times until 'BND' appears on the screen with the receiving symbol.
- Press the 'arrow up' and 'arrow down' buttons briefly and simultaneously, so that a (flashing) warning triangle and an hourglass appear in the screen as well.
- As soon as logging on is finished, the start screen will appear

💡 All functions are extensively explained in the supplied user manual.

9.4.2 Orange remote control for the installer

By means of the optionally available orange remote control, it is possible to read all information stored in the receiver. In this way, the last 20 error messages can be retrieved, and it will also be possible to read how many times an error occurred. Moreover, this remote control can also be used to adjust the basic settings and to read the magnitude of the ionization current. This remote control is also necessary for a wired home automation control.

9.5 Alternative operation

(if applicable)

In addition to the remote control, it is also possible to operate the appliance via an external source. For this purpose, a home automation system can be connected to the receiver. This can be both wired and wireless (see sections 9.5.1. and 9.5.2).

9.5.1 Wired

Wired connection of the home automation system to the receiver takes place via a 0-3VDC direct current (see fig. 9-2 (D)).

- ⚠ A higher voltage than 3V will damage the receiver and is therefore not permitted.
- 💡 In case of home automation systems with an output voltage of 0-10V, you should switch the voltage back to 0-3VDC. Use a voltage distributor made of resistors. For example, 2200 ohms and 680 ohms. The voltage above 680 ohms resistance can be used on the input of the 0-3VDC. Low ohmic resistors must be used.

By controlling the height of the voltage, the receiver will be able to calculate the position of the appliance. Graph 9.1 shows the relationship between the voltage, the height of the flame and the number of burners (1 or 2).

Proceed as follows when connecting the home automation system to the receiver:

- Connect the 0-3VDC signal to the connector, to which a black and yellow wire are connected (see fig. 9-2 (D)).
- Use the orange remote control to set the option for wired connection: go to position 8 in the first menu and select option 2 for an appliance with one burner and option 3 for an appliance with two burners. For this, read the manual for the orange remote control.
- ⚠ The yellow wire is the + pole, the black wire is the - pole. Always connect '-' to '-' and '+' to '+'.

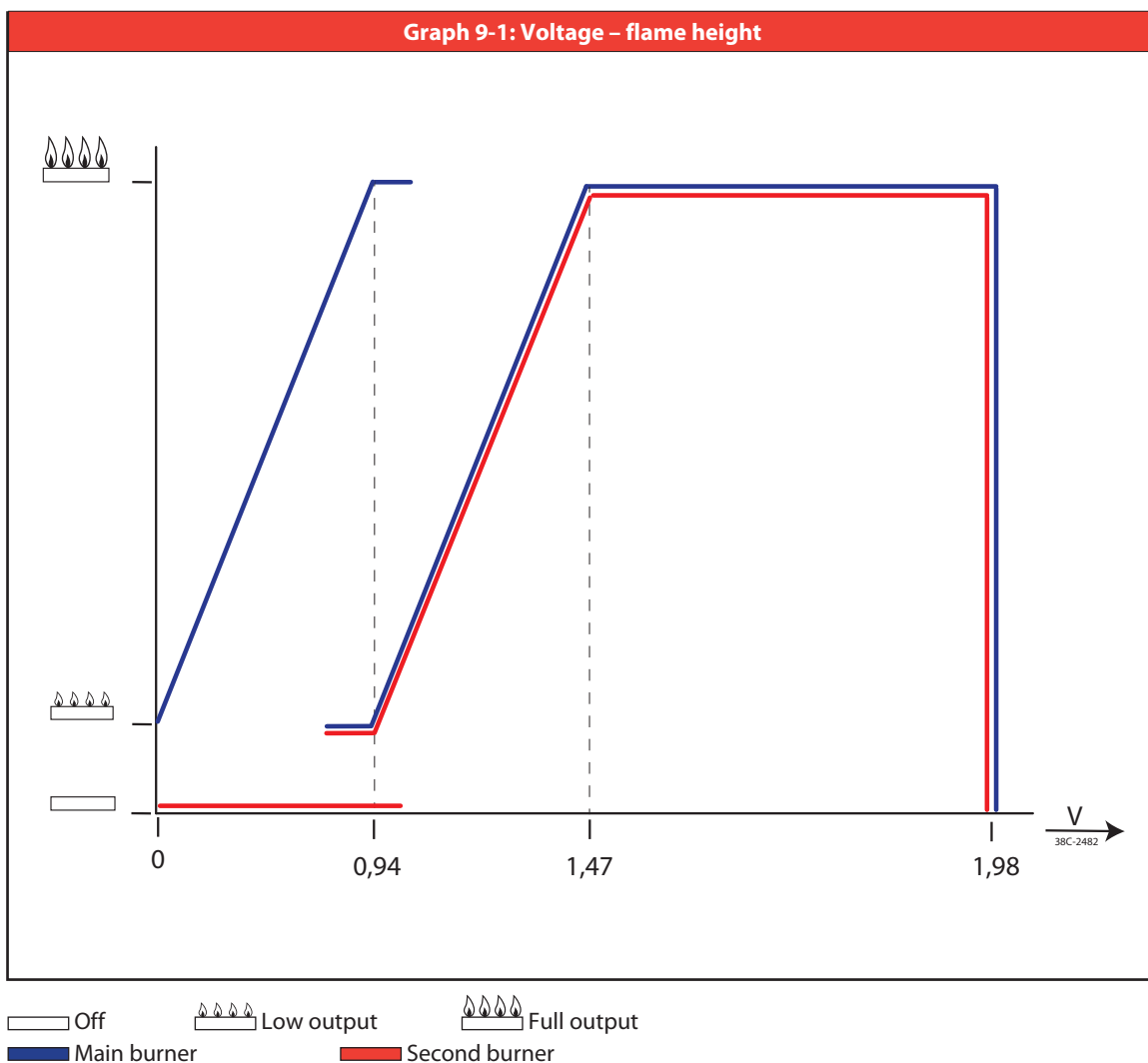

9.5.2 Wireless

The wireless connection is divided into 2 types:

- Connection via a 'modbus' protocol.
- Control via an application.

⚠ Only 1 type of wireless connection is possible on the communication module.

9.5.2.1 Connection via 'modbus' protocol

Wireless connection of a home automation system to the receiver is possible via a connection according to the 'modbus' protocol. Such a connection can only be established with a communication module (see fig. 9-1 (W)). This module can be ordered from DRU. This communication module translates the 'modbus' protocol from the home automation system into a wireless signal to the receiver.

When connecting a home automation system via the communication module to the receiver, proceed as follows:

- Use the remote control to test whether the location where the communication module will be placed is within the reach of the receiver.
- Place the remote control on this location and test the reception sensitivity (RSSI).
- Press the 'on/off' button and 'down arrow' at the same time. The value that is now visible, must be between -20 and -70 (see User Manual, "Reception Sensitivity"). If needed, hold the remote control closer to the appliance in order to improve the reception.
- Connect the communication module by means of an RJ45 plug, according to the instructions in the manual that is supplied with this module.
- Now follow the steps described in the 'modbus' protocol manual. It is available from the supplier of the home automation system.

9.5.2.2 Control via application

Also when operating the appliance via a tablet provided with the DRU Control App (iOS or Android), you will need a communication module. This module can be ordered from DRU.

In order to control the application via the DRU Control App, proceed as follows:

- Use the remote control to test whether the location where the communication module will be placed is within the reach of the receiver.
- Place the remote control on this location and test the reception sensitivity (RSSI).
- Press the 'on/off' button and 'down arrow' at the same time. The value that is now visible, must be between -20 and -70 (see User Manual, "Reception Sensitivity"). If needed, hold the remote control closer to the appliance in order to improve the reception.
- Connect the communication module by means of an RJ45 plug, according to the instructions in the manual that is supplied with the communication module.
- Use the instructions for the application in order to install it.

- ⚠ - The DRU Control app functions in accordance with the multicast and communication protocol. Ensure the router is equipped with this. For this, consult the router's installation manual.
- If the DRU Control app is used, the thermostat function no longer applies. The 'DRU Control' application is available from the Appstore, via GooglePlay or the DRU website: www.drufire.com

10. Final inspection

For a good and safe operation of the appliance, the following checks must be performed prior to commissioning.

10.1 Gas tightness

- ⚠ All connections must be gas tight. Check the connections for gas tightness. The gas control can be subjected to a maximum pressure of 50 mbar.

10.2 Gas pressure/line-pressure

The burner pressure is set at the factory; see data plate.

- ⚠ The line-pressure in house installations must be checked, because it can be wrong.
- Check the line-pressure. See fig. 6-1 (P1) for the measuring nipple on the gas control.
 - Contact the gas company if the line-pressure is too high.
 - If the line-pressure is too low, check this at the gas meter. Contact the gas company if the line-pressure is also too low at the gas meter.

10.3 Ignition main burner

For igniting the main burner, see the User Manual.

10.3.1 First ignition of the appliance after installation or adjustments

- ⚠ After installation, or after work has been performed, you should ignite the appliance for the first time without the glass pane. If necessary, bleed the gas pipe.

Proceed as follows:

1. Remove the glass pane from the appliance (see chapter 8).
2. Start the ignition procedure as described in the User Manual.

The appliance ignites on the main burner with 50% of the full output. Once the flame has passed over the main burner to the ionization and a flame has been detected, the appliance will modulate to 100%. This detection will have to take place within 15 seconds, or else the appliance will enter error mode. If the appliance has a second, separately switchable burner and the main burner continues to burn, the second valve will switch in order to ignite the second burner. Here, you can hear a clear 'click' sound. (Go to step 11 if the burner continues to burn).

If the main burner does not ignite:

3. Reset the system by pressing the buttons 'arrow up' and 'arrow down' simultaneously.
4. Repeat the ignition procedure until the main burner ignites.

- ⚠ The system can be reset and re-ignited two times in a row at maximum. Then the system will enter a hard lock-out and you will have to wait half an hour, before you can make a new attempt. Never use more than 3 attempts to ignite the appliance, as this could lead to an accumulation of gas within the appliance. Make sure that there is no more gas in the appliance before making 3 new ignition attempts.

- If you do not succeed after a few attempts, consult the diagram with error messages (see appendix 1: Malfunctions).

5. Check the flame transfer on the main burner and check whether the main burner continues to burn (go to step 11 if the burner continues to burn).

If the main burner does NOT continue to burn:

6. Mount the glass pane.
7. Reset the system by pressing the buttons 'arrow up' and 'arrow down' simultaneously.
8. Now ignite the main burner and check whether it continues to burn (go to step 12 if the burner continues to burn).

- ⚠ Limit the ignition attempts with mounted glass pane to a MAXIMUM of 1 ignition attempt.

If the main burner again does NOT continue to burn:

9. Switch off the appliance.
10. Consult the diagram with error messages (see appendix 1: Malfunctions) (Go to step 1 once the malfunction has been remedied).

If the main burner DOES continue to burn:

11. Clean the glass pane before using it for the first time, as described in the user manual. Then mount the glass pane as described in chapter 8.

12. Repeat the ignition procedure a few times and perform the checks described in section 10.3.2.

13. From now on, the main burner should ignite smoothly and continue to burn.

14. Clean the glass pane after burning for the first time, as described in the user manual.

 Always wait 5 minutes before re-igniting the appliance.

10.3.2 Procedure for igniting the main burner

-  - The ignition electrode should ignite the main burner(s) within a couple of seconds and without popping.
- The main burner(s) must pass over fluently without popping, covering the entire burner, and continue to burn.
- If the appliance does not ignite after 2 restarts and enters hard lockout, it may never be reset by disconnecting the appliance from the power supply. If a restart is necessary after all: remove or open the glass pane and make sure the gas is able to escape from the appliance. After this, the appliance may be disconnected from the power supply for 10 sec. After these 10 sec., the power supply may be reconnected.

Ignite the appliance in the same way as the first ignition, as indicated in section 10.3.1.

 Check operation of the main burner from a cold condition.

 If sparks are determined between the ignition electrodes, the main burner should burn within a few seconds.

 If NO sparks are determined, it is NOT permitted to continue the procedure.

Consult the diagram with error messages (appendix 1: (Malfunctions) if the ignition of the main burner does not comply with the above-mentioned requirements.

 The flame picture and a good flame transfer can only be properly judged if the glass pane is installed or closed.

10.4 Flame picture

The flame picture can only really be assessed when the appliance has been burning for several hours. Volatile components from paint, materials, etc., which evaporate in the first hours, will affect the flame image.

 Check that the flame picture is in order.

 Consult the diagram with error messages (appendix 1: Malfunctions) if the flame picture is not in order.

11. Delivery

Familiarise the user with the appliance. Provide the user with instructions on putting it into operation, the safety measures, the operation of the remote control and annual maintenance (see the User Manual).

- ⚠ - Tell the user to close the gas tap immediately and contact the installer in case of malfunctions/poor operation. This to prevent unsafe situations.
- Chapter 9 of the manual supplied applies to an appliance equipped with the CM system.
- Indicate the location of the gas tap.
- Point out the precautions in the User Manual against unintended ignition by other wireless remote controls such as car keys and garage door openers.
- Point out the 230 Volt connection.

- Instruct the user about the appliance and the remote control.
- When taking the appliance into operation, point out the following:
 - In order to prevent cracks, a chimney breast made of stone-like materials or finished with plaster, must dry at least 6 weeks prior to taking the appliance into operation.
 - Chapters 10 and 11 of the manual supplied apply to an appliance equipped with the CM system.
 - Volatile components from paint, materials, etc., evaporate when burning the appliance for the first time (read chapter 3 of the User Manual!).
 - During evaporation, preferably set the appliance to the highest position.
 - Make sure the room is properly ventilated.
 - Cleaning the glass pane(s).

- Give the manuals to the user (all manuals should be stored near the appliance).

12. Maintenance

Once per year, the appliance must be checked, cleaned and, if necessary, repaired by a competent installer in the field of gas heating and electricity. At least check that the appliance is working properly and safely.

- ⚠ - Always close the gas tap during maintenance work.
- Check the gas tightness after repair.
- Make sure there is no voltage on the appliance.
- **SS-absolutely do not clean the concentric system (internally) with a steel brush or metal sponge, for example. This will damage the oxide skin and could lead to leaks in the system as a result of pitting corrosion.**

- Clean the glass pane(s), if necessary.

- ⚠ - Only clean a glass pane once it has reached room temperature.
- Do not use the appliance when a glass pane is broken and/or cracked, until it has been replaced as described from section 8.1.

- ⚠ - Avoid damage to the glass pane(s).
- Avoid/remove fingerprints on the glass pane(s), since otherwise they will burn into the surface.
- Clean the pane(s) as described in the user manual.
- Regularly remove accumulated dirt, as it can burn into the glass.

- Inspect the flue gas discharge system.

- ⚠ You must always perform a final inspection.

- Perform the inspection as described in chapter 10.

12.1 Parts

Components that have to be replaced are available at the supplier.

Appendix 1: Malfunctions

| Malfunctions | | | |
|--|--|---|--|
| Error code | Problem | Possible cause | Remedy |
| F01 | Communication loss between receiver and burner device | Communication cable does not make contact | Make sure the connectors of the communication cable make proper contact |
| | | Communication cable defective | Replace communication cable |
| F02 | Receiver overheated (60° above room temperature) | Poor ventilation at receiver | Improve ventilation at receiver |
| | | Receiver makes contact with hot parts | Move receiver in such a way that there is no more contact with hot parts |
| F03 | Internal (receiver) NTC sensor does not work correctly | Receiver defective | Replace the receiver |
| F05 | Internal safety error | Receiver defective | Replace the receiver |
| F06 | Communication loss between transmitter and receiver | Transmitter is out of the receiver's range | Make sure the transmitter is near the receiver |
| | | Obstacles between transmitter and receiver that could interfere with the signal | Remove possible obstacles between transmitter and receiver |
| | | Transmission strength is too weak | Check transmission strength (see User Manual chapter 10) |
|  | Safety error transmitter | Communication loss too long (F06) | Register transmitter again |
| F08 | No ionization | No sparks | Make sure the distance between the electrodes is 3-4 mm |
| | | | Replace the spark electrodes |
| | | No gas | Check whether there is gas |
| | | | When using PowerVent®, check that the gas valve opens |
| | | Poor flame transfer main burner | Check position of blocks/chips |
| | | | If necessary, remove dust from burner openings |
| | | No good flame under ionization pin (suffocating flame) | Glass pane strips not placed correctly |
| | | | Check restriction and air inlet guide setting |
| | | | When using PowerVent®, check pressure setting |
| | | Ionization pin placed incorrectly | Place it on the right location. |
| | | Ionization pin blocked (measure ionization current when > 0 and < 1.8 uA) | Remove any vermiculite or chips from the burner |
| | | Ionization pin defective (measure ionization current when 0) | Replace the ionization pin |

| Malfunctions | | | |
|------------------|--|--|---|
| Error code | Problem | Possible cause | Remedy |
| F12 | ESYS is not released | ESYS is in hard-lock | Wait half hour until ESYS resets itself |
| F13/F14 | (no ionisation). Flame Loss when only the main burner (F13) is on or both burners (F14) are on | Ionisation pin short-circuited | Remove chips, vermiculite or glow material lying against the ionisation pin |
| | | Ionisation current too critical ($0.8 \leq \text{ionisation} < 1.8 \mu\text{A}$) | Increase ionisation current to $\geq 1.8 \mu\text{A}$ by rearranging vermiculite and removing chips and dust from the burner openings |
| | | Suffocation due to poor flue gas channel | Check the concentric system |
| | | | Check the setting of the appliance |
| | | Suffocation when using PowerVent® | Check the pressure setting of the PowerVent® system |
| | | 24 hour check control (only in case of F13) | Reset with remote control (consult PowerVent® manual) |
| | | Gas has fallen away | Check gas supply |
| | | Gas control defective (see "A" in appendix 3, fig. 38) | Replace the gas control |
| F15 | No burner device (see "C" in appendix 3, fig. 38) | Burner device came loose | Attach the burner device |
| | | Burner device incorrectly mounted | Mount the burner device correctly |
| | | Pins on the connector on the gas control are bent | Bend them straight |
| | High limit error | High limit bridge defective | Check High limit bridge ESYS |
| F15 (PowerVent®) | Fan doesn't start, appliance doesn't spark | Fan defective | Replace fan |
| | Fan starts, appliance doesn't spark | Diff. pressure hoses leak | Check connections and hoses Replace/repair |
| | | Diff. pr. sensor defective | Replace diff. pr. sensor |
| | | Ctrl signal cable defective | Replace control cable |
| | | Concentric system defective and/or leaking | Check concentric system for leaks and defects Repair/replace |
| F16 | Hardware Error ESYS | ESYS defective (burner device) | Replace ESYS (burner device) |
| F17 | 3 subsequent, unsuccessful ignition cycles | Premature interruption ignition cycle, also see F08 | After 30 min. F17 can be reset w. mains voltage on appliance, see F08 |





DRU Verwarming B.V.
The Netherlands

Postbus 1021, NL-6920 BA Duiven
Ratio 8, NL-6921 RW Duiven
